

# Solutions to Test Bank

## Chapter 2

### 2.1

(a)

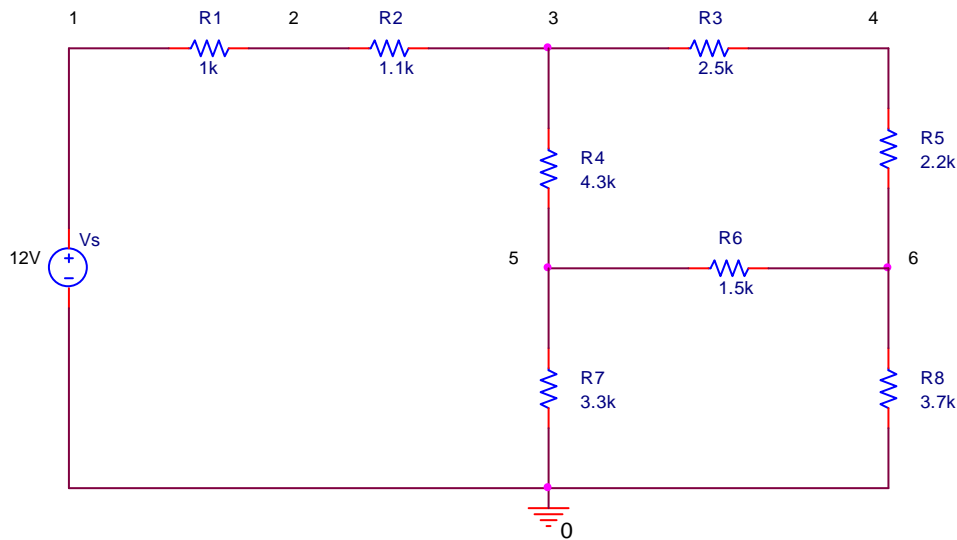

(b)

There are 7 nodes (0, 1, 2, 3, 4, 5, 6).

(c)

There are 3 simple nodes (1, 2, 4). Simple node connects two elements.

(d)

There are 4 essential nodes (1, 2, 4). Essential node connects three or more elements.

(e)

There are 9 branches.

(f)

There are three meshes:

$$V_s - R_1 - R_2 - R_4 - R_7$$

$$R_4 - R_3 - R_5 - R_6$$

$$R_7 - R_6 - R_8$$

(g)

There are 7 loops.

(h)

$$V_s - R_1 - R_2 - R_3 - R_5 - R_8$$

$$V_s - R_1 - R_2 - R_3 - R_5 - R_6 - R_7$$

$$V_s - R_1 - R_2 - R_4 - R_6 - R_8$$

$$R_7 - R_4 - R_3 - R_5 - R_8$$

## 2.2

Application of Ohm's law yields

$$I_1 = \frac{V_s}{R_1} = \frac{5 \text{ V}}{1 \text{ k}\Omega} = 5 \text{ mA}$$

$$I_2 = \frac{V_s}{R_2} = \frac{5 \text{ V}}{2 \text{ k}\Omega} = 2.5 \text{ mA}$$

$$I_3 = \frac{V_s}{R_3} = \frac{5 \text{ V}}{5 \text{ k}\Omega} = 1 \text{ mA}$$

$$p_1 = V_s \times I_1 = 5 \text{ V} \times 5 \text{ mA} = 25 \text{ mW (absorbed)}$$

$$p_2 = V_s \times I_2 = 5 \text{ V} \times 2.5 \text{ mA} = 12.5 \text{ mW (absorbed)}$$

$$p_3 = V_s \times I_3 = 5 \text{ V} \times 1 \text{ mA} = 5 \text{ mW (absorbed)}$$

$$p_{V_s} = V_s \times (-I_1 - I_2 - I_3) = -5 \text{ V} \times 8.5 \text{ mA} = -42.5 \text{ mW (released)}$$

$$p_1 + p_2 + p_3 + p_{V_s} = 0$$

## 2.3

(a)

$$V_4 = R_6 I_6 = 6 \text{ k}\Omega \times 2 \text{ mA} = 12 \text{ V}$$

(b)

$$I_5 = \frac{V_4}{R_5} = \frac{12 \text{ V}}{3 \text{ k}\Omega} = 4 \text{ mA}$$

(c)

$$I_4 = I_5 + I_6 = 4 \text{ mA} + 2 \text{ mA} = 6 \text{ mA}$$

(d)

$$V_3 = R_4 I_4 = 1 \text{ k}\Omega \times 6 \text{ mA} = 6 \text{ V}$$

(e)

$$V_2 = V_3 + V_4 = 12 \text{ V} + 6 \text{ V} = 18 \text{ V}$$

(f)

$$I_3 = \frac{V_2}{R_3} = \frac{18 \text{ V}}{6 \text{ k}\Omega} = 3 \text{ mA}$$

(g)

$$I_2 = \frac{V_2}{R_2} = \frac{18 \text{ V}}{9 \text{ k}\Omega} = 2 \text{ mA}$$

(h)

$$I_1 = I_2 + I_3 + I_4 = 2 \text{ mA} + 3 \text{ mA} + 6 \text{ mA} = 11 \text{ mA}$$

(i)

$$V_1 = R_1 I_1 = 1 \text{ k}\Omega \times 11 \text{ mA} = 11 \text{ V}$$

(j)

$$V_s = V_1 + V_2 = 11 \text{ V} + 18 \text{ V} = 29 \text{ V}$$

## 2.4

$$R_{\text{eq}} = 25 \text{ k}\Omega$$

```
% Chapter 2, Test Bank, 2.4
clear all; format long;
R1=10000;R2=33000;R3=88000;R4=19000;R5=70000;R6=12500;R7=30000;R8=42000;
Ra=P([R7,R8])
Rb=R6+Ra
Rc=P([R5,Rb])
Rd=R4+Rc
Re=P([R2,R3,Rd])
Req=R1+Re
```

Answer:

```
Ra =  
    17500  
Rb =  
    30000  
Rc =  
    21000  
Rd =  
    40000  
Re =  
    15000  
Req =  
    25000
```

## 2.5

$$R_{eq} = 3.8 \text{ k}\Omega$$

```
% Chapter 2, Test Bank, 2.5  
clear all;format long;  
R1=1700;R2=7000;R3=1800;R4=4000;R5=12000;R6=1000;R7=2000;R8=3000;R9=6000;  
Ra=P([R7,R8,R9])  
Rb=R6+Ra  
Rc=P([R4,R5,Rb])  
Rd=R3+Rc  
Re=P([R2,Rd])  
Req=R1+Re
```

Answer:

```
Ra =  
    1000  
Rb =  
    2000  
Rc =  
    1200  
Rd =  
    3000  
Re =  
    2100  
Req =  
    3800
```

## 2.6

$$R_{eq} = 2 \text{ k}\Omega$$

```
% Chapter 2, Test Bank, 2.6  
clear all;format long;  
R1=4000;R2=6000;R3=3000;R4=5000;R5=3000;R6=12000;R7=3000;R8=6000;R9=8000;  
Ra=P([R7,R8,R9])  
Rb=P([R5,R6])  
Rc=R3+Rb+Ra+R4  
Req=P([R1,R2,Rc])
```

Answer:

```
Ra =  
    1600  
Rb =  
    2400  
Rc =  
   12000  
Req =  
    2000
```

## 2.7

- (a)  $R_a = R_7 \parallel R_8 = 2 \text{ k}\Omega$   
 (b)  $R_b = R_6 + R_a = 4 \text{ k}\Omega$   
 (c)  $R_c = R_5 \parallel R_b = 2 \text{ k}\Omega$   
 (d)  $R_d = R_2 \parallel R_3 = 1.2 \text{ k}\Omega$   
 (e)  $R_{eq} = R_1 + R_d + R_4 + R_c = 6 \text{ k}\Omega$

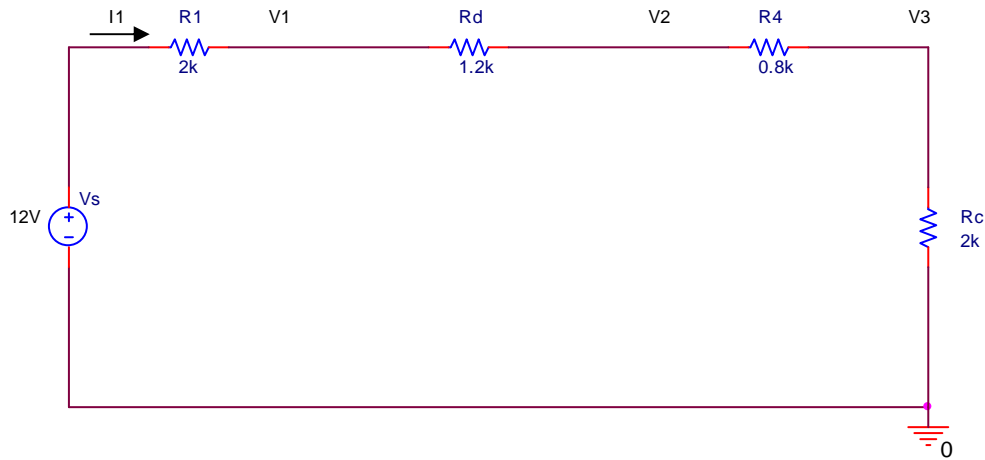

- (f)  $I_1 = V_s / R_{eq} = 12 \text{ V} / 6 \text{ k}\Omega = 2 \text{ mA}$   
 (g)  $V_{R1} = R_1 I_1 = 2 \text{ k}\Omega \times 2 \text{ mA} = 4 \text{ V}$   
 $V_{Rd} = R_d I_1 = 1.2 \text{ k}\Omega \times 2 \text{ mA} = 2.4 \text{ V}$   
 $V_{R4} = R_4 I_1 = 0.8 \text{ k}\Omega \times 2 \text{ mA} = 1.6 \text{ V}$   
 $V_{Rc} = R_c I_1 = 2 \text{ k}\Omega \times 2 \text{ mA} = 4 \text{ V}$   
 (h)  $V_1 = V_s - V_{R1} = 12 \text{ V} - 4 \text{ V} = 8 \text{ V}$   
 $V_2 = V_1 - V_{Rd} = 8 \text{ V} - 2.4 \text{ V} = 5.6 \text{ V}$   
 $V_3 = V_2 - V_{R4} = 5.6 \text{ V} - 1.6 \text{ V} = 4 \text{ V}$   
 (i)

$$I_5 = \frac{V_3}{R_5} = \frac{4 \text{ V}}{4 \text{ k}\Omega} = 1 \text{ mA}$$

$$I_6 = \frac{V_3}{R_b} = \frac{4 \text{ V}}{4 \text{ k}\Omega} = 1 \text{ mA}$$

(j)

$$V_4 = V_3 - R_6 I_6 = 4 \text{ V} - 2 \text{ k}\Omega \times 1 \text{ mA} = 4 \text{ V} - 2 \text{ V} = 2 \text{ V}$$

$$I_7 = \frac{V_4}{R_7} = \frac{2 \text{ V}}{3 \text{ k}\Omega} = 0.6667 \text{ mA}$$

$$I_8 = \frac{V_4}{R_8} = \frac{2 \text{ V}}{6 \text{ k}\Omega} = 0.3333 \text{ mA}$$

% Chapter 2, Test Bank, 2.7

Vs=12;

R1=2000;R2=2000;R3=3000;R4=800;R5=4000;R6=2000;R7=3000;R8=6000;

Ra=P([R7,R8])

Rb=R6+Ra

```

Rc=P([R5,Rb])
Rd=P([R2,R3])
Req=R1+Rd+R4+Rc
I1=Vs/Req
VR1=R1*I1
VRd=Rd*I1
VR4=R4*I1
VRC=Rc*I1
Sum1=VR1+VRd+VR4+VRC
V1=Vs-VR1
V2=Vs-VR1-VRd
V3=V2-VR4
I5=V3/R5
I6=V3/Rb
V4=V3-R6*I6
I7=V4/R7
I8=V4/R8

```

Answers:

```

Ra =
    2000
Rb =
    4000
Rc =
    2000
Rd =
    1200
Req =
    6000
I1 =
    0.002000000000000000
VR1 =
    4
VRd =
    2.400000000000000000
VR4 =
    1.600000000000000000
VRC =
    4
Sum1 =
    12
V1 =
    8
V2 =
    5.600000000000000000
V3 =
    4.000000000000000000
I5 =
    9.999999999999998e-04
I6 =
    9.999999999999998e-04
V4 =
    2
I7 =
    6.666666666666666e-04
I8 =
    3.333333333333333e-04

```

## 2.8

(a)  $R_a = R_3 \parallel R_4 = 16.8 \text{ k}\Omega$ ,  $R_b = R_5 \parallel R_6 = 19.2 \text{ k}\Omega$ ,  $R_c = R_a + R_b = 36 \text{ k}\Omega$

(b)

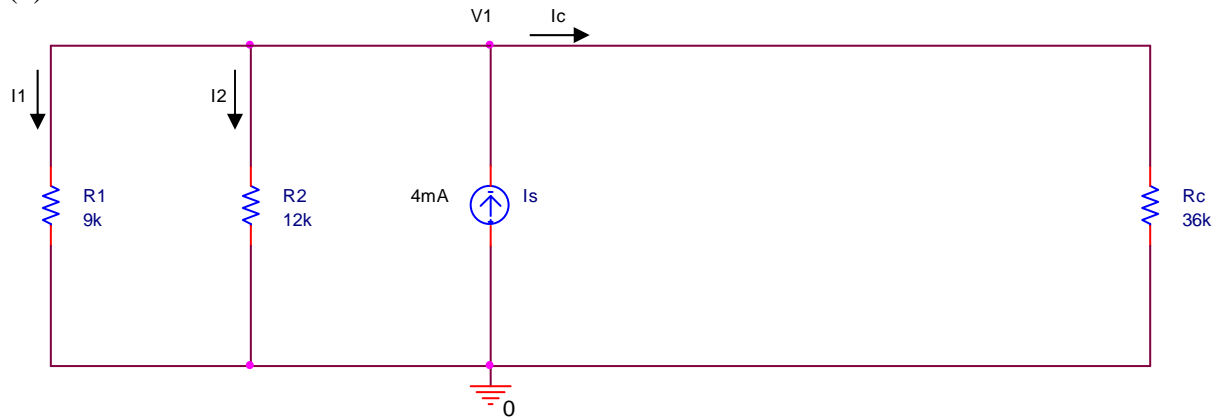

(c)

$$I_1 = I_s \times \frac{\frac{1}{R_1}}{\frac{1}{R_1} + \frac{1}{R_2} + \frac{1}{R_c}} = 4 \text{ mA} \times \frac{\frac{1}{9000}}{\frac{1}{9000} + \frac{1}{12000} + \frac{1}{36000}} = 4 \text{ mA} \times \frac{\frac{36000}{9000}}{\frac{36000}{9000} + \frac{36000}{12000} + \frac{36000}{36000}}$$

$$= 4 \text{ mA} \times \frac{4}{4+3+1} = 2 \text{ mA}$$

$$I_2 = I_s \times \frac{\frac{1}{R_2}}{\frac{1}{R_1} + \frac{1}{R_2} + \frac{1}{R_c}} = 4 \text{ mA} \times \frac{\frac{1}{12000}}{\frac{1}{9000} + \frac{1}{12000} + \frac{1}{36000}} = 4 \text{ mA} \times \frac{\frac{36000}{12000}}{\frac{36000}{9000} + \frac{36000}{12000} + \frac{36000}{36000}}$$

$$= 4 \text{ mA} \times \frac{3}{4+3+1} = 1.5 \text{ mA}$$

$$I_c = I_s \times \frac{\frac{1}{R_c}}{\frac{1}{R_1} + \frac{1}{R_2} + \frac{1}{R_c}} = 4 \text{ mA} \times \frac{\frac{1}{36000}}{\frac{1}{9000} + \frac{1}{12000} + \frac{1}{36000}} = 4 \text{ mA} \times \frac{\frac{36000}{36000}}{\frac{36000}{9000} + \frac{36000}{12000} + \frac{36000}{36000}}$$

$$= 4 \text{ mA} \times \frac{1}{4+3+1} = 0.5 \text{ mA}$$

(d)

$$I_3 = I_c \times \frac{R_4}{R_3 + R_4} = 0.5 \text{ mA} \times \frac{56}{24 + 56} k\Omega = 0.35 \text{ mA}$$

$$I_4 = I_c \times \frac{R_3}{R_3 + R_4} = 0.5 \text{ mA} \times \frac{24}{24 + 56} \text{ k}\Omega = 0.15 \text{ mA}$$

$$I_5 = I_c \times \frac{R_6}{R_5 + R_6} = 0.5 \text{ mA} \times \frac{96}{24 + 96} \text{ k}\Omega = 0.4 \text{ mA}$$

$$I_6 = I_c \times \frac{R_5}{R_5 + R_6} = 0.5 \text{ mA} \times \frac{24}{24 + 96} \text{ k}\Omega = 0.1 \text{ mA}$$

(e)

$$V_1 = R_1 I_1 = 9 \text{ k}\Omega \times 2 \text{ mA} = 18 \text{ V}$$

$$V_2 = R_5 I_5 = 24 \text{ k}\Omega \times 0.4 \text{ mA} = 9.6 \text{ V}$$

```
% Chapter 2, Test Bank, 2.8
clear all;format long;
Is=4e-3;
R1=9000;R2=12000;R3=24000;R4=56000;R5=24000;R6=96000;
Ra=P([R3,R4])
Rb=P([R5,R6])
Rc=Ra+Rb
I1=Is/R1/(1/R1+1/R2+1/Rc)
I2=Is/R2/(1/R1+1/R2+1/Rc)
Ic=Is/Rc/(1/R1+1/R2+1/Rc)
I3=Ic/R3/(1/R3+1/R4)
I4=Ic/R4/(1/R3+1/R4)
I5=Ic/R5/(1/R5+1/R6)
I6=Ic/R6/(1/R5+1/R6)
V1=R1*I1
V2=R5*I5
VR3=R3*I3
Vloop=-V1+VR3+V2
```

Answers:

```
Ra =
    16800
Rb =
    19200
Rc =
    36000
I1 =
    0.002000000000000000
I2 =
    0.001500000000000000
Ic =
    5.000000000000000e-04
I3 =
    3.500000000000000e-04
I4 =
    1.500000000000000e-04
I5 =
    4.000000000000000e-04
I6 =
    1.000000000000000e-04
V1 =
    18
V2 =
    9.600000000000000
VR3 =
    8.400000000000000
Vloop =
    1.776356839400251e-15
```



## 2.9

(a)  $R_a = R_5 \parallel R_6 = 2.4 \text{ k}\Omega$ ,  $R_b = R_3 \parallel R_4 = 3 \text{ k}\Omega$ .

(b)  $R_{eq} = 8 \text{ k}\Omega$

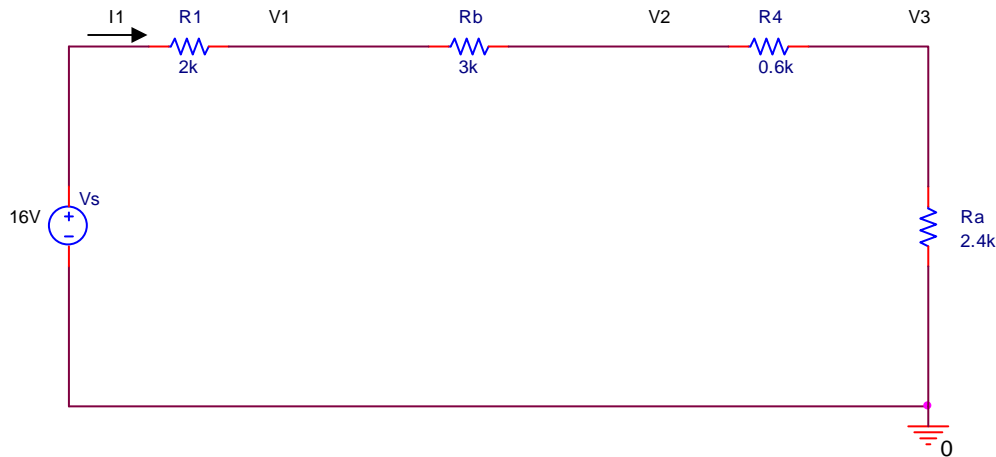

(c)

$$I_1 = \frac{V_s}{R_{eq}} = \frac{16 \text{ V}}{8 \text{ k}\Omega} = 2 \text{ mA}$$

(d)

$$V_{R1} = R_1 I_1 = 2 \text{ k}\Omega \times 2 \text{ mA} = 4 \text{ V}$$

$$V_{Rb} = R_b I_1 = 3 \text{ k}\Omega \times 2 \text{ mA} = 6 \text{ V}$$

$$V_{R4} = R_4 I_1 = 0.6 \text{ k}\Omega \times 2 \text{ mA} = 1.2 \text{ V}$$

$$V_{Ra} = R_a I_1 = 2.4 \text{ k}\Omega \times 2 \text{ mA} = 4.8 \text{ V}$$

(e)

$$V_1 = V_s - V_{R1} = 16 \text{ V} - 4 \text{ V} = 12 \text{ V}$$

$$V_2 = V_1 - V_{Rb} = 12 \text{ V} - 6 \text{ V} = 6 \text{ V}$$

$$V_3 = V_2 - V_{R4} = 6 \text{ V} - 1.2 \text{ V} = 4.8 \text{ V}$$

(f)

$$I_2 = \frac{V_{Rb}}{R_2} = \frac{6 \text{ V}}{4 \text{ k}\Omega} = 1.5 \text{ mA}$$

$$I_3 = \frac{V_{Rb}}{R_3} = \frac{6 \text{ V}}{12 \text{ k}\Omega} = 0.5 \text{ mA}$$

$$I_5 = \frac{V_{R_a}}{R_5} = \frac{4.8 \text{ V}}{4 \text{ k}\Omega} = 1.2 \text{ mA}$$

$$I_6 = \frac{V_{R_a}}{R_6} = \frac{4.8 \text{ V}}{6 \text{ k}\Omega} = 0.8 \text{ mA}$$

```
%Chapter 2, Test Bank, 2.9
clear all;
Vs=16;
R1=2000;R2=4000;R3=12000;R4=600;R5=4000;R6=6000;
Ra=P([R5,R6])
Rb=P([R2,R3])
Req=R1+Rb+R4+Ra
I1=Vs/Req
VR1=R1*I1
VRb=Rb*I1
VR4=R4*I1
VRa=Ra*I1
V1=Vs-VR1
V2=V1-VRb
V3=V2-VR4
I2=VRb/R2
I3=VRb/R3
I5=V3/R5
I6=V3/R6
```

Answers:

```
Ra =
    2400
Rb =
    3000
Req =
    8000
I1 =
    0.002000000000000000
VR1 =
     4
VRb =
     6
VR4 =
    1.2000000000000000
VRa =
    4.8000000000000000
V1 =
    12
V2 =
     6
V3 =
    4.8000000000000000
I2 =
    0.001500000000000000
I3 =
    5.0000000000000000e-04
I5 =
    0.001200000000000000
I6 =
    7.9999999999999999e-04
```

## 2.10

Delta to wye conversion:

$$R_a = \frac{R_1 R_3}{R_1 + R_2 + R_3} = 1.2 \text{ k}\Omega$$

$$R_b = \frac{R_1 R_2}{R_1 + R_2 + R_3} = 480 \Omega$$

$$R_c = \frac{R_2 R_3}{R_1 + R_2 + R_3} = 1.8 \text{ k}\Omega$$

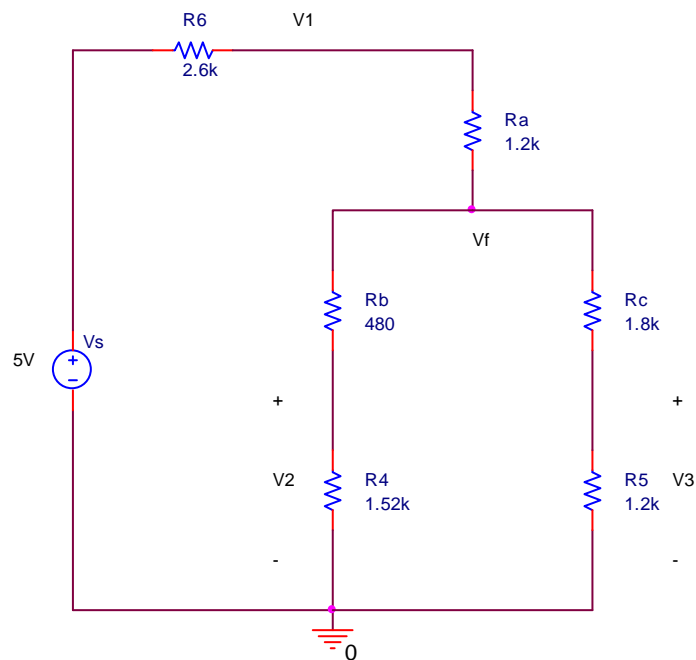

$$R_d = R_b + R_4 = 2 \text{ k}\Omega$$

$$R_e = R_c + R_5 = 3 \text{ k}\Omega$$

$$R_f = R_d \parallel R_e = 1.2 \text{ k}\Omega$$

Voltage Divider rule:

$$V_1 = V_s \times \frac{R_a + R_f}{R_6 + R_a + R_f} = 2.4 \text{ V}$$

$$V_f = V_s \times \frac{R_f}{R_6 + R_a + R_f} = 1.2 \text{ V}$$

$$V_2 = V_f \times \frac{R_4}{R_b + R_4} = 0.912 \text{ V}$$

$$V_3 = V_f \times \frac{R_5}{R_c + R_5} = 0.48 \text{ V}$$

```
% Chapter 2, Test Bank, 2.10
clear all;
Vs=5;R1=2000;R2=3000;R3=7500;R4=1520;R5=1200;R6=2600;
[Ra,Rb,Rc]=D2Y([R1,R2,R3])
Rd=Rb+R4
Re=Rc+R5
Rf=P([Rd,Re])
V1=Vs*(Ra+Rf)/(R6+Ra+Rf)
Vf=Vs*(Rf)/(R6+Ra+Rf)
V2=Vf*R4/Rd
V3=Vf*R5/Re
```

Answers:

```
Ra =
    1200
Rb =
    480
Rc =
    1800
Rd =
    2000
Re =
    3000
Rf =
    1200
V1 =
    2.4000000000000000
Vf =
    1.2000000000000000
V2 =
    0.9120000000000000
V3 =
    0.4800000000000000
```