

INSTRUCTOR'S SOLUTION MANUAL

Salmon/Johnson/Malhas

STEEL STRUCTURES Design and Behavior Fifth Edition

3.1 Compute the maximum acceptable tensile service load that may be placed on a single angle L \times 4 \times 3/4 that is welded along its long leg to a gusset plate. The live load is three times the dead load. Solve for (a) A36 steel and (b) A572 Grade 50 steel.

Section: Angle 6 \times 4 \times 3/4; $A_g = 6.94$ sq in.; $x = 1.07$ in.

Compute the effective net area A_e . When the length L of weld used is known the reduction coefficient U relating to shear lag can be computed using Eq. 3.5.2. In this case, use the practical $U = 0.85$ for an angle attached on one leg.

$$A_e = UA_g = 0.85(6.94) = 5.90 \text{ sq in.}$$

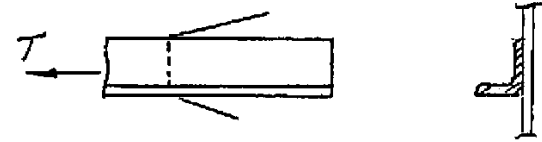

(a) A36 steel, AISC

Yielding in gross section:

$$\phi_t T_n = \phi_t F_y A_g = 0.90(36)6.94 = 225 \text{ kips} \quad \text{Controls!}$$

Fracture in effective net section:

$$\phi_t T_n = \phi_t F_u A_e = 0.75(58)5.90 = 257 \text{ kips}$$

$$\text{Factored load: } T_u = 1.2D + 1.6L = 1.2D + 1.6(3D) = 6.0D$$

$$\text{or } T_u = 1.4D$$

$$\text{Service dead load} = \phi_t T_n / 6 = 225 / 6 = 37.5 \text{ kips}$$

$$\text{Service live load} = 3D = 3(37.5) = 112 \text{ kips}$$

$$\text{Total service load } T = D + L = 37.5 + 112 = 150 \text{ kips}$$

(b) A572 Grade 50 steel, AISC

Yielding in gross section:

$$\phi_t T_n = \phi_t F_y A_g = 0.90(50)6.94 = 312 \text{ kips}$$

Fracture in effective net section:

$$\phi_t T_n = \phi_t F_u A_e = 0.75(65)5.90 = 288 \text{ kips} \quad \text{Controls!}$$

$$\text{Factored load: } T_u = 1.2D + 1.6L = 1.2D + 1.6(3D) = 6.0D$$

$$\text{or } T_u = 1.4D$$

$$\text{Service dead load} = \phi_t T_n / 6 = 288 / 6 = 47.9 \text{ kips}$$

$$\text{Service live load} = 3D = 3(47.9) = 144 \text{ kips}$$

$$\text{Total service load } T = D + L = 47.9 + 144 = 192 \text{ kips}$$

3.2 Compute the maximum acceptable tensile service load that may be placed on a single angle $L6 \times 4 \times 3/4$ that is connected along both legs. The 4-in. leg contains a single gage line of $7/8$ -in.-diam bolts and the 6-in. leg contains a double gage line of $7/8$ -in.-diam bolts. Assume no stagger, and that all bolts participate in carrying the load. The live load is three times the dead load. Solve for (a) A36 steel and (b) A572 Grade 50 steel

Section: Angle $6 \times 4 \times 3/4$; $A_g = 6.94$ sq in.; $x = 1.07$ in.

Compute the effective net area A_e . When the attachment of load carrying bolts is to both legs of an angle, the reduction coefficient U relating to shear lag can be taken as $U = 1.0$. The net area A_n is

$$A_n = A_g - 3 \text{holes}$$

$$= A_g - 3(\text{hole diam} + \frac{1}{16})t = 6.94 - 3(0.9375 + \frac{1}{16})0.75 = 4.69 \text{ sq in.}$$

$$A_e = UA_n = 1.00(4.69) = 4.69 \text{ sq in.}$$

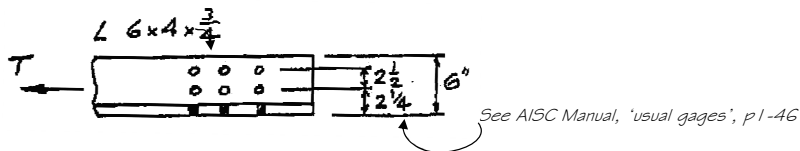

(a) A36 steel, AISC

Yielding in gross section:

$$\phi_t T_n = \phi_t F_y A_g = 0.90(36)6.94 = 225 \text{ kips}$$

Fracture in effective net section

$$\phi_t T_n = \phi_t F_u A_n = 0.75(58)4.69 = 204 \text{ kips}$$

Controls!

$$\text{Factored load: } T_u = 1.2D + 1.6L = 1.2D + 1.6(3D) = 6.0D$$

$$\text{or } T_u = 1.4D$$

$$\text{Service dead load} = \phi_t T_n / 6 = 204 / 6 = 34 \text{ kips}$$

$$\text{Service live load} = 3D = 3(34) = 102 \text{ kips}$$

$$\text{Total service load } T = D + L = 34 + 102 = 136 \text{ kips}$$

(b) A572 Grade 50 steel, AISC

$$\text{Yielding in gross section: } \phi_t T_n = \phi_t F_y A_g = 0.90(50)6.94 = 312 \text{ kips}$$

Fracture in effective net section:

$$\phi_t T_n = \phi_t F_u A_n = 0.75(65)4.69 = 229 \text{ kips}$$

Controls!

$$\text{Factored load: } T_u = 1.2D + 1.6L = 1.2D + 1.6(3D) = 6.0D$$

$$\text{or } T_u = 1.4D$$

$$\text{Service dead load} = \phi_t T_n / 6 = 229 / 6 = 38.1 \text{ kips}$$

$$\text{Service live load} = 3D = 3(38.1) = 114 \text{ kips}$$

$$\text{Total service load } T = D + L = 38.1 + 114 = 152 \text{ kips}$$

3.3 Compute the maximum acceptable service load on an A36 steel plate tension member $1/4$ -in. \times 12 in. having a single bline of holes parallel to the direction of loading. The load is 25% dead load and 75% live load, and $7/8$ -in. diam bolts are used.

AISC-J4 for connecting elements. See AISC -D3.3 for effective net area.

Compute the effective net area A_e . The reduction coefficient U relating to shear lag = 1.0. The net area A_n is

$$A_n = A_g - \text{holes}$$

$$= A_g - (\text{hole diam} + \frac{1}{16})t = 0.25(12) - 1(0.9375 + \frac{1}{16})0.25 = 2.75 \text{ sq in.}$$

$$A_e = UA_n = 1.00(2.75) = 2.75 \text{ sq in.}$$

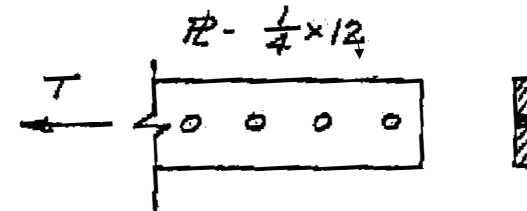

A36 steel, AISC

$$\phi_t T_n = \phi_t F_y A_g = 0.90(36)(3.00) = 97.2 \text{ kips} \quad \text{Controls!}$$

Fracture in effective net section

$$\phi_t T_n = \phi_t F_u A_n = 0.75(58)2.75 = 120 \text{ kips}$$

$$\text{Factored load: } T_u = 1.2D + 1.6L = 1.2D + 1.6(3D) = 6.0D$$

$$\text{or } T_u = 1.4D$$

$$\text{Service dead load} = \phi_t T_n / 6 = 97.2 / 6 = 16.2 \text{ kips}$$

$$\text{Service live load} = 3D = 3(16.2) = 48.6 \text{ kips}$$

$$\text{Total service load } T = D + L = 16.2 + 48.6 = 64.8 \text{ kips}$$

If this were a splice plate under AISC-J4.1,

$$\text{Max } A_n = 0.85A_g = 0.85(3.00) = 2.55 \text{ sq in, Controls for } A_e!$$

$$\text{Actual } A_n = 2.75 \text{ sq in.}$$

Fracture in effective net section:

$$\phi_t T_n = \phi_t F_u A_n = 0.75(58)2.55 = 111 \text{ kips}$$

Strength is still controlled by yielding in gross section.

$$\text{Total service load } T = D + L = 16.2 + 48.6 = 64.8 \text{ kips}$$

3.4 Compute the net area A_n for the plate (a connecting element according to AISC-J4 using both the LRFD and ASD methods) shown in the accompanying figure. Then compute the maximum value for service load T when A36 steel is used, the live load is four times the dead load, and the holes are 1 3/16-in. diameter.

Compute the effective net area A_e . The reduction coefficient U relating to shear lag = 1.0. The net area A_n is

$$A_g = (0.375)10 = 3.75 \text{ sq in.}$$

$$\begin{aligned} \text{Max } A_n &= 0.85A_g \\ &= 0.85(3.75) \\ &= 3.19 \text{ sq in.} \end{aligned}$$

Section 1-3 (no stagger):

$$\begin{aligned} A_n &= A_g - 2\text{holes} \\ &= 3.75 - 2(0.8125 + \frac{1}{16})0.375 \\ &= 3.09 \text{ sq in.} \end{aligned}$$

Section 1-2-3 with two stagger

$$\begin{aligned} A_n &= A_g - 3\text{holes} + 2\text{stagers} \\ \text{Stagger 1-2} &= 2^2 / [4(2)] = 0.50 \text{ in.} \\ \text{Stagger 2-3} &= 2^2 / [4(4)] = 0.25 \text{ in.} \\ A_n &= 3.75 - [3(0.875) - 0.50 - 0.25]0.375 \\ &= 3.05 \text{ sq in.} \quad \text{Minimum } A_n \text{ Thus, Controls!} \end{aligned}$$

Section 1-4-3 with two stagger paths:

$$\begin{aligned} A_n &= A_g - 3\text{holes} + 2\text{stagers} \\ \text{Stagger 1-4} &= 2.5^2 / [4(2)] = 0.781 \text{ in.} \\ \text{Stagger 4-3} &= 2.5^2 / [4(4)] = 0.391 \text{ in.} \\ A_n &= 3.75 - [3(0.875) - 0.781 - 0.391]0.375 \\ &= 3.94 \text{ sq in.} \end{aligned}$$

A36 steel, AISC

$$\text{Yielding in gross section: } \phi_t T_n = \phi_t F_y A_g = 0.90(36)(3.75) = 122 \text{ kips}$$

$$\text{Fracture in effective net section: } \phi_t T_n = \phi_t F_u A_n = 0.75(58)3.05 = 135 \text{ kips}$$

$$\text{Controlling } \phi_t T_n = 122 \text{ kips}$$

$$\text{Factored load: } T_u = 1.2D + 1.6L = 1.2D + 1.6(4D) = 7.6D \text{ or } T_u = 1.4D$$

$$\text{Service dead load} = \phi_t T_n / 16 = 122 / 16 = 16.0 \text{ kips}$$

$$\text{Service live load} = 4D = 4(16.0) = 64.0 \text{ kips}$$

$$\text{Total service load } T = D + L = 16.0 + 64.0 = 80.0 \text{ kips}$$

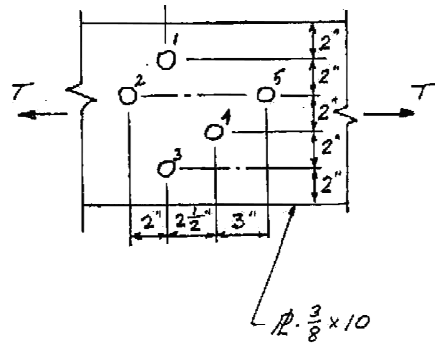

3.5 Repeat Prob. 3.4. Compute the net area A_n for the plate (a connecting element according to AISC - J4 using both the LRFD and ASD methods) shown in the accompanying figure. Then compute the maximum value for service load T when A572 Grade 60 steel is used, the live load is four times the dead load, and the holes are 15/16-in. diameter.

Compute the effective net area A_e . The reduction coefficient U relating to shear lag = 1.0. The net area A_n is

$$A_g = (0.375)10 = 3.75 \text{ sq in.}$$

$$\begin{aligned} \text{Max } A_n &= 0.85A_g \\ &= 0.85(3.75) \\ &= 3.19 \text{ sq in.} \end{aligned}$$

Section 1-3 (no stagger):

$$\begin{aligned} A_n &= A_g - 2\text{holes} \\ &= 3.75 - 2(0.9375 + \frac{1}{16})0.375 \\ &= 3.00 \text{ sq in.} \end{aligned}$$

Section 1-2-3 with two stagger paths:

$$\begin{aligned} A_n &= A_g - 3\text{holes} + 2\text{stagers} \\ \text{Stagger 1-2} &= 2^2 / [4(2)] = 0.50 \text{ in.} \\ \text{Stagger 2-3} &= 2^2 / [4(4)] = 0.25 \text{ in.} \\ A_n &= 3.75 - [3(1.00) - 0.50 - 0.25]0.375 \\ &= 2.91 \text{ sq in.} \quad \text{Minimum } A_n \text{ Thus, Controls!} \end{aligned}$$

Section 1-4-3 with two stagger paths:

$$\begin{aligned} A_n &= A_g - 3\text{holes} + 2\text{stagers} \\ \text{Stagger 1-4} &= 2.5^2 / [4(2)] = 0.781 \text{ in.} \\ \text{Stagger 4-3} &= 2.5^2 / [4(4)] = 0.391 \text{ in.} \\ A_n &= 3.75 - [3(1.00) - 0.781 - 0.391]0.375 \\ &= 3.06 \text{ sq in.} \end{aligned}$$

A572 steel, AISC

$$\text{Yielding in gross section: } \phi_t T_n = \phi_t F_y A_g = 0.90(60)(3.75) = 203 \text{ kips}$$

$$\text{Fracture in effective net section: } \phi_t T_n = \phi_t F_u A_n = 0.75(75)2.91 = 164 \text{ kips}$$

$$\text{Controlling } \phi_t T_n = 164 \text{ kips}$$

$$\text{Factored load: } T_u = 1.2D + 1.6L = 1.2D + 1.6(4D) = 7.6D \text{ or } T_u = 1.4D$$

$$\text{Service dead load} = \phi_t T_n / 16 = 164 / 16 = 21.5 \text{ kips}$$

$$\text{Service live load} = 4D = 4(21.5) = 86.0 \text{ kips}$$

$$\text{Total service load } T = D + L = 21.5 + 86.0 = 108 \text{ kips}$$

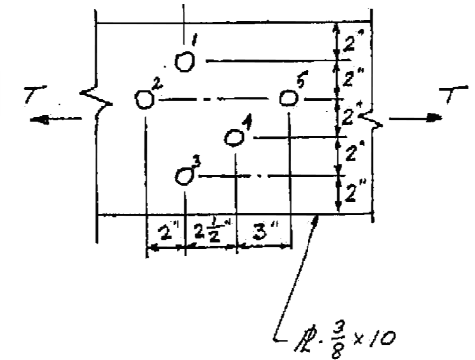

3.6 Select a pair of angles to support a tensile live load (LL) and dead load (DL) for the case assigned by the instructor. Assume the angles are separated back-to-back 3/8-in. by a connected gusset plate, and that the connection is welded. Assume the slenderness ratio is desired to not exceed 300.

Case 1; DL = 70 kips; LL = 20 kips; A36 steel; Length $L = 20$ ft.

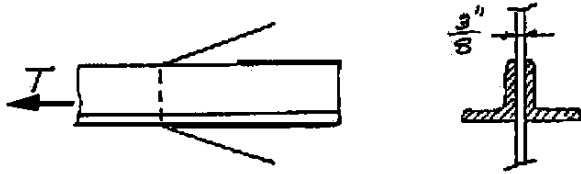

Since no holes to be deducted, $A_n = A_g$. Angles are connected along only one leg; $U = 0.85$ according to AISC-Comm.D3.3. Shear lag applies for both bolted and welded connections.

$$\text{Factored load: } T_u = 1.2D + 1.6L = 1.2(70) + 1.6(20) = 116 \text{ kips}$$

$$\text{or } T_u = 1.4(70) = 98 \text{ kips}$$

$$\text{Design strengths: } \phi_t T_n = \phi_t F_y A_g = 0.90(36)A_g = 32.4A_g \text{ (yielding)}$$

$$\phi_t T_n = \phi_t F_u A_g = 0.75(58)(0.85)A_g = 37.0A_g \text{ (fracture)}$$

Yielding of the gross section controls the design!

$$\text{Required gross area } A_g = \frac{T_u}{32.4} = \frac{116}{32.4} = 3.58 \text{ sq in.}$$

$$\text{Desired radius of gyration } r = \frac{L}{300} = \frac{20(12)}{300} = 0.8 \text{ in.}$$

From AISC Manual tables of double angle sections

$$2L-3 \times 3 \times \frac{5}{16}; A_g = 3.55 \text{ sq in.}; r_x = 0.92 \text{ in.}; r_y = 1.40 \text{ in. Close!}$$

$$2L-4 \times 3 \frac{1}{2} \times \frac{1}{4}; A_g = 3.63 \text{ sq in.}; r_x = 1.27 \text{ in.}; r_y = 1.54 \text{ in. OK}$$

(long legs back-to-back)

$$2L-4 \times 3 \frac{1}{2} \times \frac{1}{4}; A_g = 3.63 \text{ sq in.}; r_x = 1.07 \text{ in.}; r_y = 1.85 \text{ in. OK}$$

(short legs back-to-back)

$$\text{USE - } 2L-4 \times 3 \frac{1}{2} \times \frac{1}{4}; A_g = 3.63 \text{ sq in.};$$

$$2L-3 \times 3 \times \frac{5}{16} \text{ about 1\% understrength}$$

3.6 Select a pair of angles to support a tensile live load (LL) and dead load (DL) for the case assigned by the instructor. Assume the angles are separated back-to-back 3/8-in. by a connected gusset plate, and that the connection is welded. Assume the slenderness ratio is desired to not exceed 300.

Case 2; DL = 65 kips; LL = 22 kips; A36 steel; Length $L = 30$ ft.

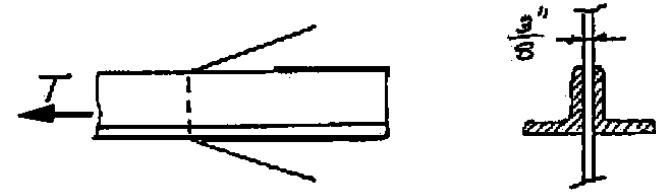

Since no holes to be deducted, $A_n = A_g$. Angles are connected along only one leg; $U = 0.85$ according to AISC-Comm.D3.3. Shear lag applies for both bolted and welded connections.

$$\text{Factored load: } T_u = 1.2D + 1.6L = 1.2(65) + 1.6(22) = 113 \text{ kips}$$

$$\text{or } T_u = 1.4(65) = 91 \text{ kips}$$

$$\text{Design strengths: } \phi_t T_n = \phi_t F_y A_g = 0.90(36)A_g = 32.4A_g \text{ (yielding)}$$

$$\phi_t T_n = \phi_t F_u A_g = 0.75(58)(0.85)A_g = 37.0A_g \text{ (fracture)}$$

Yielding of the gross section controls the design!

$$\text{Required gross area } A_g = \frac{T_u}{32.4} = \frac{113}{32.4} = 3.49 \text{ sq in.}$$

$$\text{Desired radius of gyration } r = \frac{L}{300} = \frac{30(12)}{300} = 1.2 \text{ in.}$$

From AISC Manual tables of double angle sections

$$2L-4 \times 3 \frac{1}{2} \times \frac{1}{4}; A_g = 3.63 \text{ sq in.}; r_x = 1.27 \text{ in.}; r_y = 1.54 \text{ in.}$$

(long legs back-to-back)

$$2L-5 \times 3 \frac{1}{2} \times \frac{1}{4}; A_g = 3.88 \text{ sq in.}; r_x = 1.62 \text{ in.}; r_y = 1.21 \text{ in. OK}$$

(long legs back-to-back)

$$\text{USE - } 2L-4 \times 3 \frac{1}{2} \times \frac{1}{4}; A_g = 3.63 \text{ sq in.}; \text{ long legs back-to-back}$$

3.6 Select a pair of angles to support a tensile live load (LL) and dead load (DL) for the case assigned by the instructor. Assume the angles are separated back-to-back 3/8-in. by a connected gusset plate, and that the connection is welded. Assume the slenderness ratio is desired to not exceed 300.

Case 3: DL = 70 kips; LL = 20 kips; A572 Gr 60 steel; Length $L = 20$ ft.

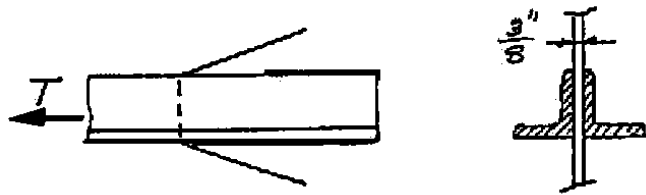

Since no holes to be deducted, $A_n = A_g$. Angles are connected along only one leg; $U = 0.85$ according to AISC-Comm.D3.3. Shear lag applies for both bolted and welded connections.

Factored load: $T_u = 1.2D + 1.6L = 1.2(70) + 1.6(20) = 116$ kips
 or $T_u = 1.4(70) = 98$ kips

Design strengths: $\phi_t T_n = \phi_t F_y A_g = 0.90(60)A_g = 54.0A_g$ (yielding)

$\phi_t T_n = \phi_t F_u A_g = 0.75(75)(0.85)A_g = 47.8A_g$ (fracture)

Fracture on effective net section controls the design!

Required gross area $A_g = \frac{T_u}{47.8} = \frac{116}{47.8} = 2.43$ sq in.

Desired radius of gyration $r = \frac{L}{300} = \frac{20(12)}{300} = 0.8$ in.

From *AISC Manual* tables of double angle sections

$2L-3 \times 2\frac{1}{2} \times \frac{1}{4}$; $A_g = 2.63$ sq in.; $r_x = 0.945$ in.; $r_y = 1.13$ in. OK

(long legs back - to - back)

$2L-2\frac{1}{2} \times 2 \times \frac{5}{16}$; $A_g = 2.62$ sq in.; $r_x = 0.776$ in.; $r_y = 0.948$ in. Close!

(long legs back - to - back)

USE - $2L-3 \times 2\frac{1}{2} \times \frac{1}{4}$; $A_g = 2.63$ sq in.; long legs back-to-back

3.6 Select a pair of angles to support a tensile live load (LL) and dead load (DL) for the case assigned by the instructor. Assume the angles are separated back-to-back 3/8-in. by a connected gusset plate, and that the connection is welded. Assume the slenderness ratio is desired to not exceed 300.

Case 4: DL = 48 kips; LL = 30 kips; A36; Length $L = 22$ ft.

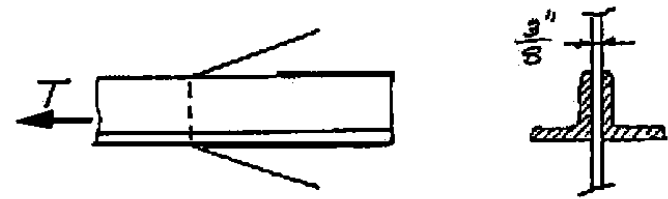

Since no holes to be deducted, $A_n = A_g$. Angles are connected along only one leg; $U = 0.85$ according to AISC-Comm.D3.3. Shear lag applies for both bolted and welded connections.

Factored load: $T_u = 1.2D + 1.6L = 1.2(48) + 1.6(30) = 106$ kips
 or $T_u = 1.4(48) = 67$ kips

Design strengths: $\phi_t T_n = \phi_t F_y A_g = 0.90(36)A_g = 32.4A_g$ (yielding)

$\phi_t T_n = \phi_t F_u A_g = 0.75(58)(0.85)A_g = 37.0A_g$ (fracture)

Yielding of the gross section controls the design!

Required gross area $A_g = \frac{T_u}{32.4} = \frac{106}{32.4} = 3.27$ sq in.

Desired radius of gyration $r = \frac{L}{300} = \frac{22(12)}{300} = 0.88$ in.

From *AISC Manual* tables of double angle sections

$2L-4 \times 3 \times \frac{1}{4}$; $A_g = 3.38$ sq in.; $r_x = 1.28$ in.; $r_y = 1.29$ in. CHOICE 1

(long legs back - to - back)

$2L-3\frac{1}{2} \times 3\frac{1}{2} \times \frac{1}{4}$; $A_g = 3.38$ sq in.; $r_x = 1.09$ in.; $r_y = 1.59$ in. CHOICE 2

(long legs back - to - back)

$2L-3 \times 2 \times \frac{3}{8}$; $A_g = 3.47$ sq in.; $r_x = 0.940$ in.; $r_y = 0.917$ in. CHOICE 3

(long legs back - to - back)

USE - $2L-4 \times 3 \times \frac{1}{4}$; $A_g = 3.38$ sq in.; long legs back - to - back

3.6 Select a pair of angles to support a tensile live load (LL) and dead load (DL) for the case assigned by the instructor. Assume the angles are separated back-to-back 3/8-in. by a connected gusset plate, and that the connection is welded. Assume the slenderness ratio is desired to not exceed 300.

Case 5: DL = 50 kips; LL = 30 kips; $F_y = 50$ ksi; Length $L = 20$ ft.

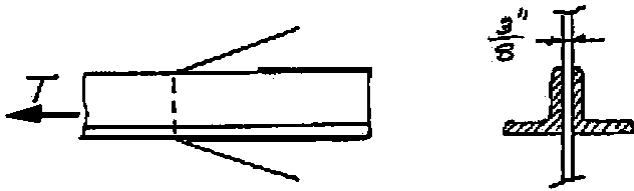

Since no holes to be deducted, $A_n = A_g$. Angles are connected along only one leg; $U = 0.85$ according to AISC- Comm.D3.3. Shear lag applies for both bolted and welded connections.

Factored load: $T_u = 1.2D + 1.6L = 1.2(50) + 1.6(30) = 108$ kips
or $T_u = 1.4(50) = 70$ kips

Design strengths: $\phi_t T_n = \phi_t F_y A_g = 0.90(50)A_g = 45.0A_g$ (yielding)

$\phi_t T_n = \phi_t F_u A_n = 0.75(65)(0.85) A_g = 41.4A_g$ (fracture)

Fracture on effective net section controls the design!

Required gross area $A_g = \frac{T_u}{\phi_t} = \frac{108}{41.4} = 2.61$ sq in.

Desired radius of gyration $r = \frac{L}{300} = \frac{20(12)}{300} = 0.80$ in.

From AISC Manual tables of double angle sections

$2L-2\frac{1}{2} \times 2 \times \frac{15}{16}$; $A_g = 2.62$ sq in.; $r_x = 0.776$ in.; $r_y = 0.948$ in. Close!

(long legs back - to - back) $KL/r = 309 > 300$ limit N.G.

$2L-3 \times 2\frac{1}{2} \times \frac{1}{4}$; $A_g = 2.63$ sq in.; $r_x = 0.945$ in.; $r_y = 1.13$ in. CHOICE 1

(long legs back - to - back)

$2L-3 \times 2\frac{1}{2} \times \frac{1}{4}$; $A_g = 2.63$ sq in.; $r_x = 0.753$ in.; $r_y = 1.45$ in. Close!

(short legs back - to - back) $KL/r = 309 > 300$ limit N.G.

USE - $2L-3 \times 2\frac{1}{2} \times \frac{1}{4}$; $A_g = 2.63$ sq in.; long legs back - to - back

3.6 Select a pair of angles to support a tensile live load (LL) and dead load (DL) for the case assigned by the instructor. Assume the angles are separated back-to-back 3/8-in. by a connected gusset plate, and that the connection is welded. Assume the slenderness ratio is desired to not exceed 300.

Case 6: DL = 80 kips; LL = 30 kips; A36 steel; Length $L = 20$ ft.

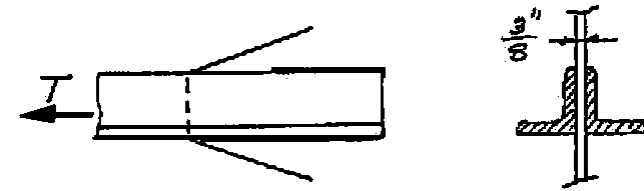

Since no holes to be deducted, $A_n = A_g$. Angles are connected along only one leg; $U = 0.85$ according to AISC- Comm.D3.3. Shear lag applies for both bolted and welded connections.

Factored load: $T_u = 1.2D + 1.6L = 1.2(80) + 1.6(30) = 144$ kips

or $T_u = 1.4(80) = 112$ kips

Design strengths: $\phi_t T_n = \phi_t F_y A_g = 0.90(36)A_g = 32.4A_g$ (yielding)

$\phi_t T_n = \phi_t F_u A_n = 0.75(58)(0.85) A_g = 37.0A_g$ (fracture)

Yielding of the gross section controls the design!

Required gross area $A_g = \frac{T_u}{\phi_t} = \frac{144}{32.4} = 4.44$ sq in.

Desired radius of gyration $r = \frac{L}{300} = \frac{20(12)}{300} = 0.80$ in.

From AISC Manual tables of double angle sections

$2L-4 \times 4 \times \frac{5}{16}$; $A_g = 4.80$ sq in.; $r_x = 1.24$ in.; $r_y = 1.80$ in. OK

(long legs back - to - back)

$2L-4 \times 3\frac{1}{2} \times \frac{5}{16}$; $A_g = 4.49$ sq in.; $r_x = 1.26$ in.; $r_y = 1.55$ in. CHOICE 1

(long legs back - to - back)

USE - $2L-4 \times 3\frac{1}{2} \times \frac{5}{16}$; $A_g = 4.49$ sq in.; long legs back-to-back

3.6 Select a pair of angles to support a tensile live load (LL) and dead load (DL) for the case assigned by the instructor. Assume the angles are separated back-to-back 3/8-in. by a connected gusset plate, and that the connection is welded. Assume the slenderness ratio is desired to not exceed 300.

Case 7: DL = 80 kips; LL = 100 kips; $F_y = 50$ ksi; Length $L = 28$ ft.

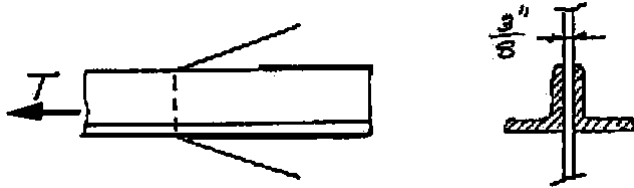

Since no holes to be deducted, $A_n = A_g$. Angles are connected along only one leg; $U = 0.85$ according to AISC-Comm.D3.3. Shear lag applies for both bolted and welded connections.

Factored load: $T_u = 1.2D + 1.6L = 1.2(80) + 1.6(100) = 256$ kips
or $T_u = 1.4(80) = 112$ kips

Design strengths: $\phi_t T_n = \phi_t F_y A_g = 0.90(50)A_g = 45.0A_g$ (yielding)

$$\phi_t T_n = \phi_t F_u A_n = 0.75(65)(0.8) A_g = 39.0A_g \text{ (fracture)}$$

Fracture on effective net section controls the design!

$$\text{Required gross area } A_g = \frac{T_u}{41.4} = \frac{256}{41.4} = 6.18 \text{ sq in.}$$

$$\text{Desired radius of gyration } r = \frac{L}{300} = \frac{28(12)}{300} = 1.12 \text{ in.}$$

From AISC Manual tables of double angle sections

$$2L-4 \times 4 \times \frac{1}{2}; A_g = 7.50 \text{ sq in.}; r_x = 1.22 \text{ in.}; r_y = 1.83 \text{ in.} \quad \text{OK}$$

$$2L-4 \times 3 \frac{1}{2}; A_g = 6.50 \text{ sq in.}; r_x = 1.25 \text{ in.}; r_y = 1.33 \text{ in.} \quad \text{CHOICE 1}$$

(long legs back - to - back)

$$2L-6 \times 3 \frac{1}{2} \times \frac{8}{8}; A_g = 6.84 \text{ sq in.}; r_x = 1.94 \text{ in.}; r_y = 1.39 \text{ in.} \quad \text{CHOICE 2}$$

(long legs back - to - back)

$$\text{USE - } 2L-4 \times 3 \frac{1}{2}; A_g = 6.50 \text{ sq in.}; \text{ long legs back-to-back}$$

3.7 Select a single angle (for the case assigned by the instructor) to support a tensile live load (LL) and dead load (DL). A single gage line of at least three bolts is to be used. Assume shear rupture (i.e., block shear) strength does not control. Assume the slenderness ratio is desired to not exceed 300.

Case 1: DL = 15 kips; LL = 40 kips; A36 steel; Length $h = 15$ ft; 3/4-in. diam bolts.

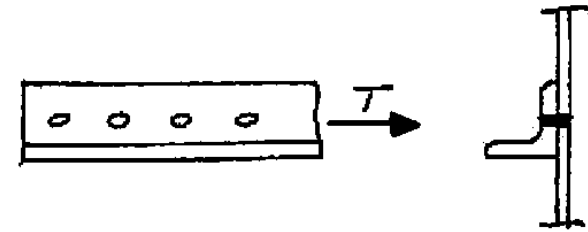

This is a long member; thus, AISC-J4 does not apply. Connection is to one leg; thus, take $U = 0.85$ according to AISC-Comm.D3.3. (at least for preliminary selection).

Factored load: $T_u = 1.2D + 1.6L = 1.2(15) + 1.6(40) = 82$ kips

or $T_u = 1.4(15) = 21$ kips

Design strengths: $\phi_t T_n = \phi_t F_y A_g = 0.90(36)A_g = 32.4A_g$ (yielding)

$$\phi_t T_n = \phi_t F_u A_n = 0.75(58)(0.85) A_g = 37.0A_g \text{ (fracture)}$$

$$\text{Required gross area } A_g = \frac{T_u}{32.4} = \frac{82}{32.4} = 2.53 \text{ sq in.}$$

$$\text{Required net area } A_n = \frac{T_u}{37.0} = \frac{82}{37.0} = 2.22 \text{ sq in.}$$

$$\text{Desired radius of gyration } r_z = \frac{L}{300} = \frac{15(12)}{300} = 0.60 \text{ in.}$$

From the AISC Manual tables of single angle sections

$$L - 5 \times 3 \frac{1}{2} \times \frac{5}{16}; A_g = 2.56 \text{ sq in.}; r_z = 0.766 \text{ in.} \quad \text{OK}$$

$$A_n = 2.56 - 0.875(5/16) = 2.29 \text{ sq in.}$$

$$U = 1 - \bar{x}/L = 1 - (\text{std gage } -y)/L = 1 - (3 - 1.59)/10 = 0.86$$

$$L - 4 \times 3 \frac{1}{2} \times \frac{3}{8}; A_g = 2.67 \text{ sq in.}; r_z = 0.727 \text{ in.} \quad \text{OK}$$

$$A_n = 2.67 - 0.875(3/8) = 2.34 \text{ sq in.}$$

$$U = 1 - \bar{x}/L = 1 - (\text{std gage } -y)/L = 1 - (2.5 - 1.21)/10 = 0.87$$

$$\text{USE - } L - 5 \times 3 \frac{1}{2} \times \frac{5}{16}; A_g = 2.56 \text{ sq in.}; \text{ long leg connected}$$

3.7 Select a single angle (for the case assigned by the instructor) to support a tensile live load (LL) and dead load (DL). A single gage line of at least three bolts is to be used. Assume shear rupture (i.e., block shear) strength does not control. Assume the slenderness ratio is desired to not exceed 300.

Case 2: DL = 15 kips; LL = 40 kips; A572 Grade 50 steel;
Length $L = 15$ ft; 3/4-in. diam bolts.

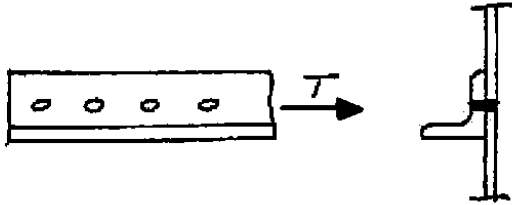

This is a long member; thus, AISC-J4 does not apply. Connection is to one leg; thus, take $U = 0.85$ according to AISC-Comm.D3.3. (at least for preliminary selection).

Factored load: $T_u = 1.2D + 1.6L = 1.2(15) + 1.6(40) = 82$ kips
or $T_u = 1.4(15) = 21$ kips

Design strengths: $\phi_t T_n = \phi_t F_y A_g = 0.90(50)A_g = 45.0A_g$ (yielding)

$\phi_t T_n = \phi_t F_u A_n = 0.75(65)(0.8) A_n = 39.0A_n$ (fracture)

Required gross area $A_g = \frac{T_u}{\phi_t F_y} = \frac{82}{45} = 1.82$ sq in.

Deduct = (Bolt Diam + 0.125) t for standard holes = 0.875 t

Required net area $A_n = \frac{T_u}{\phi_t F_u} = \frac{82}{41.4} = 1.98$ sq in. CONTROLS!

Desired radius of gyration $r_z = \frac{L}{300} = \frac{15(12)}{300} = 0.60$ in.

From the AISC Manual tables of single angle sections

L - $4 \times 3\frac{1}{2} \times \frac{5}{16}$; $A_g = 2.25$ sq in.; $r_z = 0.730$ in. OK

$A_n = 2.25 - 0.875(5/16) = 1.98$ sq in.

$U = 1 - \bar{x}/L = 1 - (\text{std gage } -y)/L = 1 - (2.5 - 1.18)/10 = 0.87$

L - $5 \times 3 \times \frac{5}{16}$; $A_g = 2.40$ sq in.; $r_z = 0.658$ in. OK

$A_n = 2.40 - 0.875(5/16) = 2.13$ sq in.

$U = 1 - \bar{x}/L = 1 - (\text{std gage } -y)/L = 1 - (3 - 1.68)/10 = 0.87$

L - $4 \times 4 \times \frac{5}{16}$; $A_g = 2.40$ sq in.; $r_z = 0.791$ in. OK

USE - L - $4 \times 3\frac{1}{2} \times \frac{5}{16}$; $A_g = 2.25$ sq in.; long leg connected

3.7 Select a single angle (for the case assigned by the instructor) to support a tensile live load (LL) and dead load (DL). A single gage line of at least three bolts is to be used. Assume shear rupture (i.e., block shear) strength does not control. Assume the slenderness ratio is desired to not exceed 300.

Case 3: DL = 15 kips; LL = 40 kips; A572 Grade 60 steel;

Length $L = 25$ ft; 7/8-in. diam bolts.

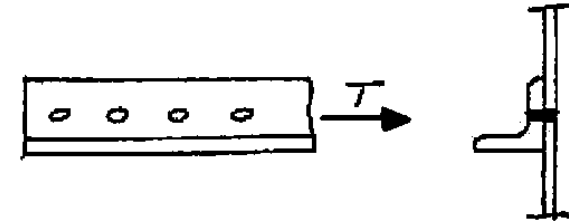

This is a long member; thus, AISC-J4 does not apply. Connection is to one leg; thus, take $U = 0.85$ according to AISC-Comm.D3.3. (at least for preliminary selection).

Factored load: $T_u = 1.2D + 1.6L = 1.2(15) + 1.6(40) = 82$ kips
or $T_u = 1.4(15) = 21$ kips

Design strengths: $\phi_t T_n = \phi_t F_y A_g = 0.90(60)A_g = 54.0A_g$ (yielding)

$\phi_t T_n = \phi_t F_u A_n = 0.75(75)(0.85) A_n = 47.8A_n$ (fracture)

Required gross area $A_g = \frac{T_u}{\phi_t F_y} = \frac{82}{54} = 1.52$ sq in.

Deduct = (Bolt Diam + 0.125) t for standard holes = 1.0 t

Required net area $A_n = \frac{T_u}{\phi_t F_u} = \frac{82}{47.8} = 1.72$ sq in. CONTROLS!

Desired radius of gyration $r_z = \frac{L}{300} = \frac{25(12)}{300} = 1.0$ in.

From the AISC Manual tables of single angle sections

L - $5 \times 5 \times \frac{5}{16}$; $A_g = 3.03$ sq in.; $r_z = 0.994$ in. CLOSE!

$A_n = 3.03 - 1.0(5/16) = 2.72$ sq in.

$U = 1 - \bar{x}/L = 1 - (\text{std gage } -y)/L = 1 - (3 - 1.37)/10 = 0.84$

SLENDERNESS CONTROLS!

USE - L - $5 \times 5 \times \frac{5}{16}$; $A_g = 3.03$ sq in.

3.8 Select a standard threaded rod to carry a tensile force T of 4 kips dead load and 6 kips live load. Use A572 Grade 50 steel.

DL = 4 kips; LL = 6 kips; A572 Grade 50 steel;

The design strength of a threaded rod is given by AISC – J3.6 (Table J3.2)

$$\text{Factored load: } T_u = 1.2D + 1.6L = 1.2(4) + 1.6(6) = 14.4 \text{ kips}$$

$$\text{or } T_u = 1.4(4) = 5.6 \text{ kips}$$

$$\text{Design strengths: } \phi_t T_n = 0.75A_b F_n = 0.75A_b (0.75F_u)$$

Using the minimum tensile strength F_u for A572 Grade 50 steel as 65 ksi from AISC Table 2-5, and equating the factored load T_u to the design strength $\phi_t T_n$ gives the required gross A_b area from Eq. As

$$\text{Required } A_b = \frac{\text{Required } \phi_t T_n}{0.75(0.75F_u)} = \frac{14.4}{0.75(0.75)(65)} = 0.39 \text{ sq in}$$

Select a standard threaded rod based on the required area A_b . The area computed is the gross area A_b based on the diameter of the unthreaded body of the rod (AISC – Table 7-1.8).

USE $\frac{3}{4}$ in. – diam rod (10 threads per inch) ($A_b = 0.442 \text{ sq in.}$)

3.9 Select a standard threaded rod to carry a tensile force T of 2 kips dead load and 4 kips live load. Use A36 steel.

DL = 2 kips; LL = 4 kips; A36 steel;

The design strength of a threaded rod is given by AISC – J3.6 (Table J3.2)

$$\text{Factored load: } T_u = 1.2D + 1.6L = 1.2(2) + 1.6(4) = 8.8 \text{ kips} \quad \text{or}$$

$$T_u = 1.4(2) = 2.8 \text{ kips}$$

$$\text{Design strengths: } \phi_t T_n = 0.75A_b F_n = 0.75A_b (0.75F_u)$$

Using the minimum tensile strength F_u for A36 steel as 58 ksi from AISC Table 2-5, and equating the factored load T_u to the design strength $\phi_t T_n$ gives the required gross A_b area from Eq. As

$$\text{Required } A_b = \frac{\text{Required } \phi_t T_n}{0.75(0.75F_u)} = \frac{8.8}{0.75(0.75)(58)} = 0.27 \text{ sq in}$$

Select a standard threaded rod based on the required area A_b . The area computed is the gross area A_b based on the diameter of the unthreaded body of the rod (AISC – Table 7-1.8).

USE $\frac{5}{8}$ in. – diam rod (11 threads per inch) ($A_b = 0.307 \text{ sq in.}$)

3.10 Design sag rods to support the purlins of an industrial building roof whose span and slope are shown in the accompanying figure. Sag rods are placed at 1/3 points between roof misses, which are spaced 30 ft apart. Assume roofing and purlin weight is 9 psf of roof surface. Use standard threaded rods and A36 steel. The snow load to be carried is 20, 30, or 40 psf of horizontal projection, whichever is appropriate for your locale.

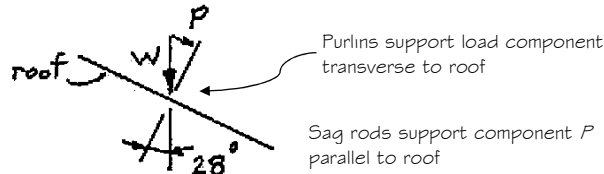

Load combination = 1.2D + 1.6 SNOW

Factored load:

Snow intensity =	20	30	40 psf
DL per sq ft of roof =	10.8	10.8	10.8
SNOW = $w \cos(\text{angle})$ =	<u>28.25</u>	<u>42.38</u>	<u>56.51</u>
	39.05	53.18	67.31 psf

Factored force on sag rods:

$$\text{Roof area} = [24/(\cos 28^\circ)](\text{spacing}) = (24/0.8830)30 = 815.5 \text{ sq ft}$$

Force on rods is component parallel to roof.

$$T_v = w_v (\sin 28^\circ)(\text{roof area}) = \begin{matrix} 15.0 & 20.4 & 25.8 \text{ kips} \end{matrix}$$

With sag rods at 1/3 points, assume each carries $P/3$.

$$T_v = \begin{matrix} 4.98 & 6.79 & 8.59 \text{ kips} \end{matrix}$$

The strength requirement of AISC-J3.6 is

$$\phi_t T_n \geq T_v$$

$$\phi_t T_n = \phi_t (0.75 F_u) A_b = 0.75(0.75)(58)A_b = 32.6 A_b$$

Required area $A_b = \frac{T_v}{32.6}$	0.153	0.208	0.263 sq in.
--	-------	-------	--------------

SELECT RODS: (from AISC Manual Table 7-18, p. 7-83)

Diameter	1/2	5/8	5/8 in.
Actual Area A_b =	0.196	0.307	0.307 sq in.

3.11 Determine the maximum allowable tensile load (20% dead load, 80% live load) for a single C15x33.9 fastened to a 1/2-in. gusset plate as in the accompanying figure. Use A36 steel and assume holes are for 3/4-in. diam bolts.

Properties: $A_g = 9.96 \text{ sq in.}$

$$t_w = 0.40 \text{ in.}$$

Since there are three bolts

per line, take $U = 0.85$ according to AISC-Comm.D3.3, par (b).

Alternatively, compute

$$U = 1 - \bar{x}/L \\ = 1 - 0.787/6 = 0.87 < 0.90 \text{ max} \\ \text{as per AISC-D3.3.}$$

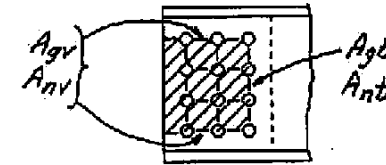
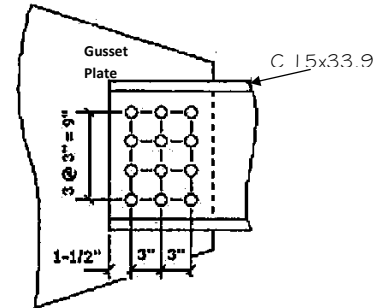

Design strengths:

$$\phi_t T_n = \phi_t F_y A_g = 0.90(36)9.96 = 323 \text{ kips (yielding)}$$

$$A_n = A_g - 4 \text{ holes} = 9.96 - 4(d_b + 1/8)t_w \\ = 9.96 - 4(0.875)(0.40) = 8.56 \text{ sq in.}$$

$$\phi_t T_n = \phi_t F_u A_g = 0.75(58)(0.87)8.56 = 324 \text{ kips (fracture)}$$

Block shear strength:

$$A_{gv} = 9t_w = 9(0.40) = 3.60 \text{ sq in.}$$

$$A_{nt} = (9 - 3d_b)t_w = [9 - 3(0.875)](0.40) = 2.55 \text{ sq in.}$$

$$A_{gv} = 2(7.5)t_w = 2(7.5)(0.40) = 6.00 \text{ sq in.}$$

$$A_{nv} = (15 - 5d_b)t_w = [15 - 5(0.875)](0.40) = 4.25 \text{ sq in.}$$

Check:

$$[F_u A_{nt} = 58(2.55) = 148 \text{ kips}] \approx [0.6 F_u A_{nv} = 0.6(58)4.25 = 148 \text{ kips}]$$

Thus, shear fracture—tension yielding controls!

$$T_n = 0.6 F_u A_{nv} + F_y A_{gv} = 0.6(58)4.25 + 36(3.60) = 278 \text{ kips}$$

$$\phi_t T_n = 0.75(278) = 208 \text{ kips}$$

CONTROLS!

$$T_v = 1.2 \text{ DL} + 1.6 \text{ LL} = \phi_t T_n = 208 \text{ kips}$$

$$T_v = 1.2(0.2r) + 1.6(0.8T) = 208 \text{ kips}$$

$$T = 137 \text{ kips}; T_{DL} = 27.4 \text{ kips}; T_{LL} = 109 \text{ kips}$$

Allowable service load, $T = 137 \text{ kips!}$

3.12 Determine the maximum allowable tensile load (20% dead load, 80% live load) for a single C 10x25 fastened to a 5/8-in. gusset plate as in the accompanying figure. Use A36 steel and assume holes are for 3/4-in. diam bolts. Base answer on tension strength of the channel and include shear rupture (block shear) strength.

Properties: $A_g = 7.35$ sq in.

$t_w = 0.526$ in.

Since there are three bolts per line, $U = 0.85$ as per AISC - Comm.D3.3, par (b).

Alternatively, compute

$$U = 1 - \bar{x}/L$$

$$= 1 - 0.617/9 = 0.93 > 0.90 \text{ max}$$

as per AISC - D3.3.

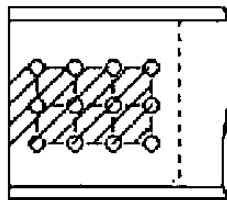
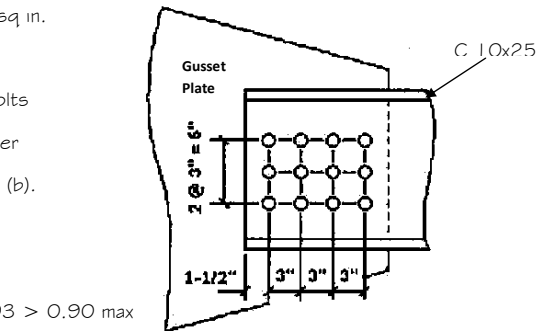

Design strengths:

$$\phi_t T_n = \phi_t F_y A_g = 0.90(36)7.35 = 238 \text{ kips (yielding)}$$

$$A_n = A_g - 3 \text{ holes} = 9.96 - 3(d_b + 1/8)t_w$$

$$= 9.96 - 3(0.875)(0.526) = 5.97 \text{ sq in.}$$

$$\phi_t T_n = \phi_t F_u A_g = 0.75(58)(0.90)5.97 = 234 \text{ kips (fracture)}$$

Block shear strength: Channel web is thinner than gusset plate

$$A_{gt} = 6t_w = 6(0.526) = 3.16 \text{ sq in.}$$

$$A_{nt} = (6 - 2d_b)t_w = [6 - 2(0.875)](0.526) = 2.24 \text{ sq in.}$$

$$A_{gv} = 2(10.5)t_w = 2(10.5)(0.526) = 11.05 \text{ sq in.}$$

$$A_{nv} = (21 - 7d_b)t_w = [21 - 7(0.875)](0.526) = 7.82 \text{ sq in.}$$

Check:

$$[F_u A_{nt} = 58(2.24) = 130 \text{ kips}] \approx [0.6F_u A_{nv} = 0.6(58)7.82 = 272 \text{ kips}]$$

Thus, shear fracture—tension yielding controls!

$$T_n = 0.6F_u A_{nv} + F_y A_{gt} = 0.6(58)7.82 + 36(3.16) = 386 \text{ kips}$$

$$\phi_t T_n = 0.75(386) = 289 \text{ kips; Thus, member fracture controls!}$$

$$T_v = 1.2DL + 1.6LL = \phi_t T_n = 234 \text{ kips}$$

$$T_v = 1.2(0.2r) + 1.6(0.8T) = 234 \text{ kips}$$

$$T = 154 \text{ kips; } T_{DL} = 31 \text{ kips; } T_{LL} = 123 \text{ kips}$$

Allowable service load, $T = 154$ kips!

3.13 Determine the maximum allowable tensile load (15% dead load, 85% live load) for a pair of angles L6x4x3/8 attached to a gusset plate as shown. Use A36 steel and 3/4-in. diam bolts on standard gage lines. The force is transmitted to the gusset plate by the fasteners on lines A and B. The holes in the outstanding legs are open.

Properties: $A_g = 7.22$ sq in.

Since there are three bolts per line, $U = 0.85$ as per AISC - Comm.D3.3, par (b).

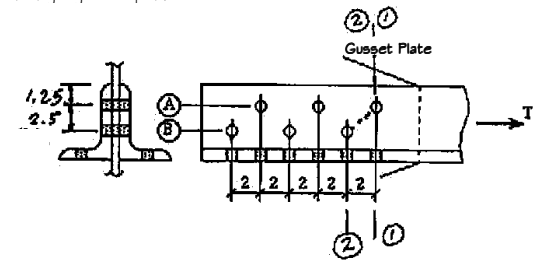

Alternatively, compute

$$U = 1 - \bar{x}/L$$

$$= 1 - 0.941/10 = 0.91 > 0.90 \text{ max}$$

as per AISC - D3.3.

Compute net area: $t = 2(0.375) = 0.75$ in.

Section 1-1 (two holes out):

$$A_n = A_g - 2 \text{ holes}$$

$$= 7.22 - 2(0.75 + 0.125)(0.75) = 5.91 \text{ sq in.}$$

Section 2-2 (3 holes staggered):

$$A_n = A_g - 3 \text{ holes} + (s^2/4g)t$$

$$= 7.22 - 3(0.75 + 0.125)(0.75) - r[2^2/4(2.5)](0.75) = 5.55 \text{ sq in.}$$

Design strengths:

$$\phi_t T_n = \phi_t F_y A_g = 0.90(36)7.22 = 234 \text{ kips (yielding)}$$

$$\phi_t T_n = \phi_t F_u A_g = 0.75(58)(0.90)5.55 = 217 \text{ kips (fracture)}$$

Block shear strength: Include diagonal in shear path.

$$A_{gt} = 1.25 t_w = 1.25(0.75) = 0.94 \text{ sq in.}$$

$$A_{nt} = (3.15 - 1 d_b)t_w = [3.75 - 1(0.875)](0.75) = 2.16 \text{ sq in.}$$

$$A_{gv} = [9.5 + \sqrt{2^2 + 2.5^2}] t_w = [9.5 + 3.20](0.75) = 9.53 \text{ sq in.}$$

$$A_{nv} = A_g - 3.5d_b t_w = 9.53 - 3.5(0.875)(0.75) = 7.23 \text{ sq in.}$$

Check: $[F_u A_{nt} = 58(2.16) = 125 \text{ kips}] < [0.6F_u A_{nv} = 0.6(58)7.23 = 252 \text{ kips}]$

Thus, shear fracture—tension yielding controls!

$$T_n = 0.6F_u A_{nv} + F_y A_{gt} = 0.6(58)7.23 + 36(0.94) = 285 \text{ kips}$$

$$\phi_t T_n = 0.75(285) = 214 \text{ kips; Thus, block shear controls!}$$

$$T_v = 1.2(0.15r) + 1.6(0.852T) = 214 \text{ kips}$$

$$T = 139 \text{ kips; } T_{DL} = 21 \text{ kips; } T_{LL} = 118 \text{ kips}$$

Allowable service load, $T = 139$ kips!

3.14 Determine the maximum allowable tensile load (15% dead load, 85% live load) for a pair of angles L8x6x3/4 attached to a gusset plate as shown. Use A36 steel and 7/8-in. diam bolts on standard gage lines. The force is transmitted to the gusset plate by the fasteners on lines A and B. The holes in the outstanding legs are open.

Properties: $A_g = 19.90$ sq in.

Since there are three bolts per line, $U = 0.85$ as per AISC - Comm.D3.3, par (b).

Alternatively, compute $U = 1 - \bar{x}/L$

$$= 1 - 1.56/10 = 0.84 < 0.90 \text{ max}$$

as per AISC - D3.3.

Compute net area: $t = 2(0.75) = 1.50$ in.

Section 1-1 (two holes out):

$$\begin{aligned} A_n &= A_g - 2 \text{ holes} \\ &= 19.90 - 2(0.875 + 0.125)1.50 \\ &= 16.90 \text{ sq in.} \end{aligned}$$

Section 2-2 (3 holes staggered):

$$\begin{aligned} A_n &= A_g - 3 \text{ holes} + (s^2/4g)t \\ &= 19.90 - 3(0.875 + 0.125)1.50 + [2^2/4(3)]1.50 = 15.9 \text{ sq in.} \end{aligned}$$

Design strengths:

$$\phi_t T_n = \phi_t F_y A_g = 0.90(36)19.9 = 645 \text{ kips (yielding)}$$

$$\phi_t T_n = \phi_t F_u A_g = 0.75(58)(0.84)15.9 = 581 \text{ kips (fracture)}$$

Block shear strength: Include diagonal in shear path.

$$A_{gt} = 2.0t_w = 2.0(1.50) = 3.00 \text{ sq in.}$$

$$A_{nt} = (5.00 - 1d_h)t_w = [5.00 - 1(1.00)]1.50 = 6.00 \text{ sq in.}$$

$$A_{gv} = [9.5 + \sqrt{2^2 + 3^2}]t_w = [9.5 + 3.61]1.50 = 19.7 \text{ sq in.}$$

$$A_{nv} = A_{gv} - 3.5d_h t_w = 19.7 - 3.5(1.00)1.50 = 14.5 \text{ sq in.}$$

$$\text{Check: } [F_u A_{nt} = 58(6.00) = 348 \text{ kips}] < [0.6F_u A_{nv} = 0.6(58)14.5 = 505 \text{ kips}]$$

Thus, shear fracture—tension yielding controls!

$$T_n = 0.6F_u A_{nv} + F_y A_{gt} = 0.6(58)14.5 + 36(3.00) = 613 \text{ kips}$$

$$\phi_t T_n = 0.75(613) = 459 \text{ kips; Thus, block shear controls!}$$

$$T_v = 1.2(0.1570 + 1.6(0.857-)) = 459 \text{ kips}$$

$$T = 298 \text{ kips; } T_{DL} = 45 \text{ kips; } T_{LL} = 253 \text{ kips}$$

Allowable service load, $T = 298$ kips!

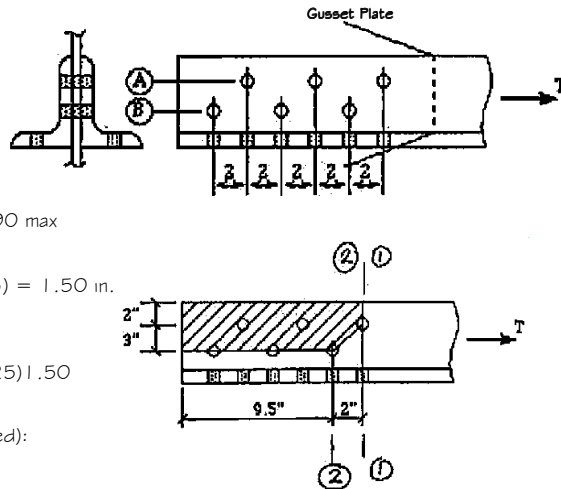

3.15. Given the splice shown in the accompanying figure: (a) Determine the maximum capacity T (25% dead load, 75% live load) based on the A346 steel plates having holes arranged as shown, (b) What value of s should be specified to provide the maximum capacity T as computed in pan (a), if the final design is to have $s_1 = s_2 = s$?

The 5/16-in. plates are governed by AISC-J4; $A_n < 0.85A_g$.

$$A_g = 2(10)0.3125 = 6.25 \text{ sq in.};$$

$$\text{Max } A_n = 0.85(6.25) = 5.31 \text{ sq in.}$$

Compute net area:

$$t = 2(0.3125) = 0.625 \text{ in.}$$

Section 1-1 (two holes out):

$$\begin{aligned} A_n &= A_g - 2 \text{ holes} \\ &= 6.25 - 2(0.875 + 0.125)0.625 \\ &= 5.00 \text{ sq in.} \end{aligned}$$

Design strengths:

$$\phi_t T_n = \phi_t F_y A_g = 0.90(36)6.25 = 203 \text{ kips (yielding) CONTROLS!}$$

$$\phi_t T_n = \phi_t F_u A_g = 0.75(58)(1.0)5.00 = 218 \text{ kips (fracture)}$$

Section 1-1 (3 holes staggered):

$$\begin{aligned} A_n &= A_g - 3 \text{ holes} + \sum (s^2/4g)t \\ &= 6.25 - 3(0.875 + 0.125)0.625 + 2[s^2/4(2)]0.625 \\ &= [203/(0.75)58] = 4.66 \text{ sq in.} \end{aligned}$$

Solve for $s = 1.34$ in.

Compute block shear through A-1-2-B. The tensile area is known, but the shear area is a function of s .

$$A_{gt} = 4.0t = 4.0(0.625) = 2.50 \text{ sq in.}$$

$$A_{nt} = A_{gt} - 1d_h t = 2.50 - 1.0(0.625) = 1.88 \text{ sq in.}$$

$$A_{gv} = 2(2s + 1.5)t = 2(2s + 1.5)0.625 = 2.5s + 1.88$$

$$A_{nv} = A_{gv} - 3d_h t_w = 2.5s + 1.88 - 3(1.00)0.625 = 2.5s$$

$$\text{Check: } [F_u A_{nt} = 58(1.88) = 145 \text{ kips}] < [0.6F_u A_{nv} = 0.6(58)2.5s = 113 \text{ kips}]$$

Thus, shear yield - tension fracture controls!

$$\begin{aligned} \phi_t T_n &= \phi_t T_n [0.6F_y A_{gv} + F_u A_{nt}] = 0.75[0.6(36)(2.5s + 1.88) + 58(1.88)] \\ &= 0.75[54s + 149.6] = 203 \text{ kips} \end{aligned}$$

Solve for $s = 2.24$ in. Check strength when $s = 2.25$ in.

$$\begin{aligned} \phi_t T_n &= \phi_t [0.6F_y A_{nv} + F_y A_{gt}] = 0.75[0.6(58)2.5s + 36(2.50)] \\ &= 0.75[87(2.25) + 90] = 214 \text{ kips} \end{aligned}$$

Member strength, $\phi_t T_n = 203$ kips; USE $s = 2.25$ in.

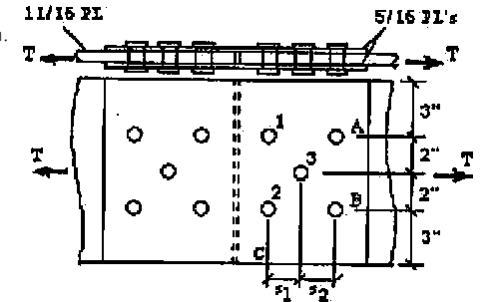

3.16. An L5x3-1/2x1/2 angle, as shown in the accompanying figure, is to carry 20 kips dead load and 70 kips live load using the shortest length of connection using two gage lines of bolts in the 5-in. leg. What is the minimum acceptable stagger, theoretical and specified (1/2-in. multiples), using A572 Grade 50 steel? Neglect shear rupture strength.

$$A_g = 4.00 \text{ sq in.}$$

Since there are three bolts per line, $U = 0.85$ as per

AISC - Comm.D3.3, par (b).

Alternatively, compute

as per AISC - D3.3.

$$U = 1 - \bar{x}/L \\ = 1 - 0.906/45$$

For $s = 1.5$, $U = 0.85$

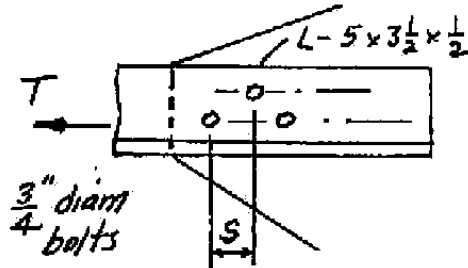

Section with one hole out:

$$A_n = A_g - 1 \text{ holes} = 4.00 - 1(0.75 + 0.125)0.50 = 3.56 \text{ sq in.}$$

Factored load: $T_u = 1.2D + 1.6L = 1.2(20) + 1.6(70) = 136 \text{ kips}$

or $T_u = 1.4(20) = 28 \text{ kips}$

Maximum design strengths:

$$\phi_t T_n = \phi_t F_y A_g = 0.90(50)4.00 = 180 \text{ kips (yielding)}$$

$$\phi_t T_n = \phi_t F_u A_e = \phi_t F_u U A_n = 0.75(65)(0.85)3.56 = 148 \text{ kips (fracture)}$$

Section staggered through two holes:

$$A_n = A_g - 2 \text{ holes} + (s^2/A_g)t \\ = 4.00 - 2(0.75 + 0.125)0.50 + [s^2/4(1.75)]0.50 \\ = 3.13 + 0.0714s^2$$

Required net area $A_n = 136/[0.75(0.85)65] = 3.28 \text{ sq in.}$

$$A_n = 3.13 + 0.0714s^2 = 3.28 \text{ sq in.}$$

$s = 1.48$; say $s = 1.5 \text{ in.}$

Check efficiency factor $U = 1 - \bar{x}/L = 1 - 0.906/[4(1.5)] = 0.85$

Check stagger for minimum spacing of 2.67 diameters.

$$[2.67(0.75)]^2 = s^2 + 1.75^2$$

$$s = 0.97 \text{ in.}$$

Member strength, $\phi_t T_n = 136 \text{ kips}$; USE $s = 1.5 \text{ in.}$

3.17. An L5x3-1/2x1/2 angle, as shown in the accompanying figure, is to carry 20 kips dead load and 60 kips live load. Using one gage line of holes for 7/8-in. diam bolts in each leg, what is the minimum stagger s , to accomplish this? Consider the load to be transferred by bolts in the 5 in. leg while the holes in the 3-1/2 in. leg are to be considered open. Use A36 steel. Neglect shear rupture strength.

$$A_g = 4.00 \text{ sq in.}$$

Since there are three bolts

per line, $U = 0.85$ as per

AISC - Comm.D3.3, par (b).

Alternatively, compute

as per AISC - D3.3.

$$U = 1 - \bar{x}/L \\ = 1 - 0.906/4s$$

For $s = 1.5$, $U = 0.85$

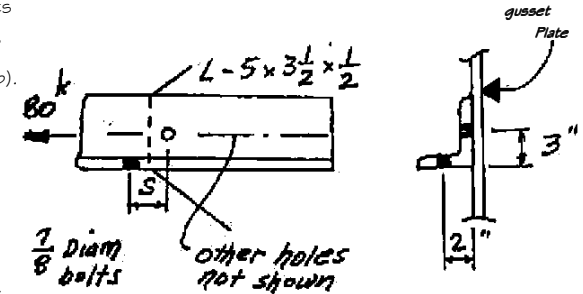

Section with one hole out:

$$A_n = A_g - 1 \text{ holes} = 4.00 - 1(0.875 + 0.125)0.50 = 3.50 \text{ sq in.}$$

Factored load: $T_u = 1.2D + 1.6L = 1.2(20) + 1.6(60) = 120 \text{ kips}$

or $T_u = 1.4(20) = 28 \text{ kips}$

Maximum design strengths:

$$\phi_t T_n = \phi_t F_y A_g = 0.90(36)4.00 = 130 \text{ kips (yielding)}$$

$$\phi_t T_n = \phi_t F_u A_e = \phi_t F_u U A_n = 0.75(58)(0.85)3.50 = 129 \text{ kips (fracture)}$$

Section staggered through two holes:

Gage $g = 3 + 2 - t = 3 + 2 - 0.5 = 4.5 \text{ in.}$

$$A_n = A_g - 2 \text{ holes} + (s^2/A_g)t \\ = 4.00 - 2(0.875 + 0.125)0.50 + [s^2/4(4.5)]0.50 \\ = 3.00 + 0.0278s^2$$

Required net area $A_n = 120/[0.75(0.85)58] = 3.25 \text{ sq in.}$

$$A_n = 3.00 + 0.0278s^2 = 3.25 \text{ sq in.}$$

$$s = 3.00 \text{ in.}$$

Check efficiency factor

$$U = 1 - \bar{x}/L = 1 - 0.906/[4(3)] = 0.92 > 0.90 \text{ max}$$

Check stagger for minimum spacing of 2.67 diameters.

$$[2.67(0.875)]^2 = s^2 + 4.5^2$$

Min $s = \text{none}$

Member strength, $\phi_t T_n = 120 \text{ kips}$; USE $s = 3 \text{ in.}$

3.18. Compute the minimum value of s that could be used on the angle shown in the figure, such that the maximum factored tensile force T_n may be carried. Assume m is large enough so that a failure pattern through the open hole will not govern. Include consideration of shear rupture strength. Use A36 steel with 1-in. diam bolts.

$$A_g = 6.48 \text{ sq in.}$$

Since there are at least three bolts per line, $U = 0.85$ as per AISC

Commentary - D3.3, par (b).

Alternatively, compute as per AISC - D3.3 $U = 1 - \bar{x}/L = 1 - 0.963/L$

For $L = 6.4$ in., $U = 0.85$

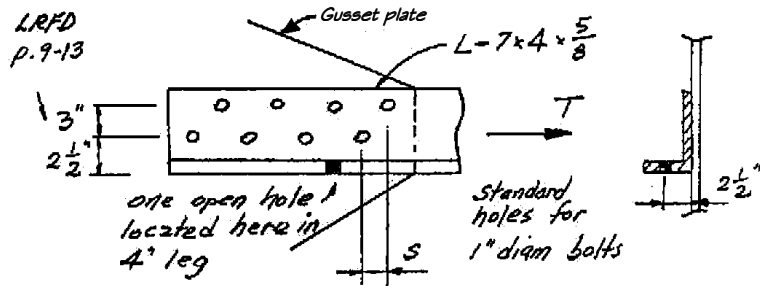

Section with one hole out:

$$A_n = A_g - 1 \text{ holes} = 6.48 - 1(1.00 + 0.125)0.625 = 5.78 \text{ sq in.}$$

Maximum design strengths:

$$\phi_t T_n = \phi_t F_y A_g = 0.90(36)6.48 = 210 \text{ kips (yielding)}$$

$$\phi_t T_n = \phi_t F_u A_e = \phi_t F_u U A_n = 0.75(58)(0.85)5.78 = 214 \text{ kips (fracture)}$$

Section staggered through two holes:

Gage $g_1 = 2.5$ in.; $g_2 = 3$ in.; $g = 2.5$ in., AISC Manual, p. 10-10.

$$A_n = A_g - 2 \text{ holes} + (s^2 / 4g)t = 6.48 - 2(1.00 + 0.125)0.625 + [s^2 / 4(3.0)]0.625 = 5.07 + 0.0521s^2$$

Required net area $A_n = 210 / [0.75(0.85)58] = 5.68 \text{ sq in.}$

$$A_n = 5.07 + 0.0521s^2 = 5.68 \text{ sq in.}; \quad s = 3.42 \text{ in.}$$

Check $U = 1 - \bar{x}/L = 1 - 0.963 / [> 4(3.42)] = > 0.90$ max; use 0.90

Revised Req'd $A_n = 210 / [0.75(58)0.90] = 5.36 \text{ sq in.}; \quad \text{Max } s = 2.36 \text{ in.}$

Check rupture shear strength: Include diagonal in shear path.

$$A_{gt} = (7 - g_2 - g_1)t = (7 - 3 - 2.5)0.625 = 0.94 \text{ sq in.}$$

$$A_{nt} = A_{gt} - 0.5d_n t = 0.94 - 0.5(1.00 + 0.125)0.625 = 0.59 \text{ sq in.}$$

$$A_{gv} = [1.5 + 6s + \sqrt{s^2 + 3^2}]t = [1.5 + 6(2.36) + \sqrt{2.36^2 + 3^2}]0.625 = 12.17 \text{ sq in.}$$

$$A_{nv} = A_{gv} - 3.5d_n t = 12.17 - 3.5(1.125)0.625 = 9.71 \text{ sq in.}$$

$$\text{Check: } [F_u A_{nt} = 58(0.59) = 34 \text{ kips}] < [0.6F_u A_{nv} = 0.6(58)9.71 = 338 \text{ kips}]$$

Thus, shear fracture - tension yielding controls!

$$T_n = 0.6F_u A_{nv} + F_y A_{gt} = 0.6(58)9.71 + 36(0.94) = 372 \text{ kips}$$

$$\phi_t T_n = 0.75(372) = 279 \text{ kips; Shear rupture strength does NOT control!}$$

Member strength, $\phi_t T_n = 210 \text{ kips}; \text{ Minimum } s = 2.36 \text{ in.}$

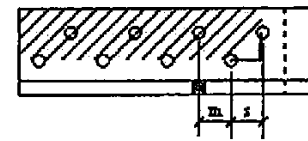

Practical solution:

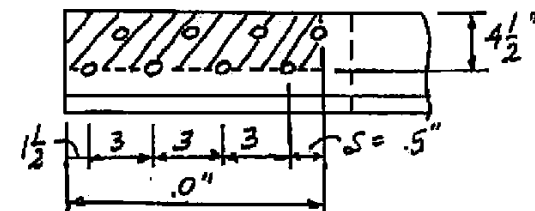

3.19. Assuming that s for the angle of Prob. 3.18 is made as large as required in Prob. 3.18, compute the minimum distance m required so that the open hole in the 4-in. leg will not reduce the strength below its maximum possible value. If Prob. 3.18 is not solved, assume s is 3.75 in. Use A36 steel with 1-in. diam bolts.

$$A_g = 6.48 \text{ sq in.}$$

Since there are at least three bolts per line, $U = 0.85$ as per AISC

Commentary - D3.3, par (b). $U = 0.90$ according to Prob. 3.18.

Max $\phi_t T_n = 210$ kips (Prob. 3.18); Minimum $s = 2.36$ in.; $A_n = 5.36$ sq in.

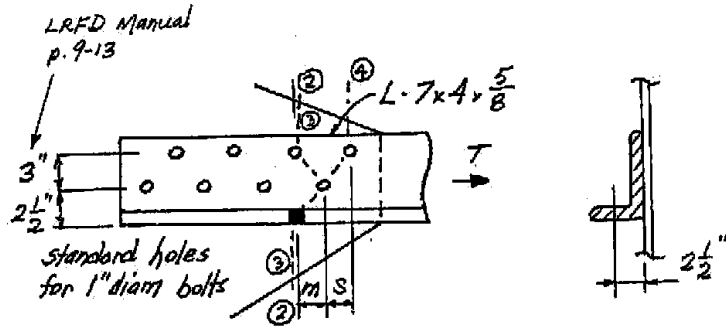

Failure through the open hole is computed using section 2-2 with $6/8$ of the load acting (the open hole is not involved in load transmission). If m is small, failure may be through three holes with 100% of load.

Section 2-2 with $6/8$ of load acting:

$$A_n = A_g - 2 \text{ holes} = 6.48 - 2(1.00 + 0.125)0.625 = 5.07 \text{ sq in.}$$

$$6/8 \text{ of required } A_n = (6/8)5.36 = 4.02 \text{ sq in. (does not control)}$$

Section 3-3 with $7/8$ of load acting:

$$\text{Gage } g \text{ (short leg)} = 2.5 \text{ in.}; g \text{ (around corner)} = 2.5 + 2.5 - 0.625 = 4.375 \text{ in.}$$

$$A_n = A_g - 3 \text{ holes} + \sum (s^2 / 4g)t$$

$$= 6.48 - 3(1.00 + 0.125)0.625 + [m^2 / 4(3) + m^2 / 4(4.375)]0.625$$

$$= 4.37 + m^2 / 11.39$$

$$7/8 \text{ of required } A_n = (7/8)5.36 = 4.69 \text{ sq in.}$$

$$4.69 = 4.37 + m^2 / 11.39; \text{ Required } m = 1.91 \text{ in.}$$

Problem 3.19, page 2 of 2

Section 4-3 with 100% of load acting:

Assume $s = 2.36$ in. (Minimum indicated from Prob. 3.18)

$$A_n = A_g - 3 \text{ holes} + \sum (s^2 / 4g)t$$

$$= 6.48 - 3(1.00 + 0.125)0.625 + [s^2 / 4(3) + m^2 / 4(4.375)]0.625$$

$$= 4.37 + [2.36^2 / 4(3) + m^2 / 4(4.375)]0.625 = 4.66 + m^2 / 28$$

$$5.36 = 4.66 + m^2 / 28; \text{ Required } m = 4.43 \text{ in.}$$

USE $s \geq 2.36$ in. and $m \geq 4.43$ in. for full strength of angle.

For practicality,

USE $s = 2.5$ in. and $m = 4.5$ in. for full strength of angle.

If $s = 3.75$ in. as given if Prob. 3.18 was not solved,

$$A_n = A_g - 3 \text{ holes} + \sum (s^2 / 4g)t$$

$$= 6.48 - 3(1.00 + 0.125)0.625 + [s^2 / 4(3) + m^2 / 4(4.375)]0.625$$

$$= 4.37 + [3.75^2 / 4(3) + m^2 / 4(4.375)]0.625 = 5.10 + m^2 / 28$$

$$5.36 = 5.10 + m^2 / 28; \text{ Required } m = 2.70 \text{ in.}$$

USE $s = 3.75$ in. and $m = 2.70$ in. for full strength of angle.

3.20. Design an eyebar to carry 24 kips dead load and 76 kips live load, using flame-cut A572 Grade 50 steel plate. (Refer to AISC – D.D6)

DL = 24 kips; LL = 76 kips; A572 Grade 50 steel, AISC;

Yielding in gross section:

$$\phi_t T_n = 0.9 A_g F_y = 0.9 A_g (50) = 45 A_g \quad \text{CONTROLS!}$$

Fracture in effective net section:

$$\phi_t T_n = 0.75 A_e F_u = 0.75 A_e (65) = 48.75 A_e$$

$$\text{Factored load: } T_u = 1.2D + 1.6L = 1.2(24) + 1.6(76) = 150.4 \text{ kips}$$

$$\text{or } T_u = 1.4(24) = 33.6 \text{ kips}$$

Yielding on gross section controls the design! AISC – D6

$$\text{Required gross area } A_g = \frac{T_u}{45} = \frac{150.4}{45} = 3.34 \text{ sq in}$$

Select a standard threaded rod based on the required area A_b . The area computed is the gross area A_b based on the diameter of the unthreaded body of the rod (AISC – Table 7-18).

USE - $2\frac{1}{4}$ in. – diam rod (4.5 threads per inch) ($A_b = 3.98$ sq in.)