

# ***Solutions Manual***

for

Heat and Mass Transfer: Fundamentals & Applications

Fourth Edition

Yunus A. Cengel & Afshin J. Ghajar

McGraw-Hill, 2011

## **Chapter 1**

# **INTRODUCTION AND BASIC CONCEPTS**

### **PROPRIETARY AND CONFIDENTIAL**

This Manual is the proprietary property of The McGraw-Hill Companies, Inc. (“McGraw-Hill”) and protected by copyright and other state and federal laws. By opening and using this Manual the user agrees to the following restrictions, and if the recipient does not agree to these restrictions, the Manual should be promptly returned unopened to McGraw-Hill: **This Manual is being provided only to authorized professors and instructors for use in preparing for the classes using the affiliated textbook. No other use or distribution of this Manual is permitted. This Manual may not be sold and may not be distributed to or used by any student or other third party. No part of this Manual may be reproduced, displayed or distributed in any form or by any means, electronic or otherwise, without the prior written permission of McGraw-Hill.**

## Thermodynamics and Heat Transfer

**1-1C** Thermodynamics deals with the amount of heat transfer as a system undergoes a process from one equilibrium state to another. Heat transfer, on the other hand, deals with the rate of heat transfer as well as the temperature distribution within the system at a specified time.

**1-2C** The description of most scientific problems involves equations that relate the *changes* in some key variables to each other, and the smaller the increment chosen in the changing variables, the more accurate the description. In **the limiting case of infinitesimal changes in variables**, we obtain *differential equations*, which provide precise mathematical formulations for the physical principles and laws by representing the rates of changes as *derivatives*.

As we shall see in later chapters, the differential equations of fluid mechanics are known, but very difficult to solve except for very simple geometries. Computers are extremely helpful in this area.

**1-3C** (a) The driving force for heat transfer is the temperature difference. (b) The driving force for electric current flow is the electric potential difference (voltage). (a) The driving force for fluid flow is the pressure difference.

**1-4C** The caloric theory is based on the assumption that heat is a fluid-like substance called the "caloric" which is a massless, colorless, odorless substance. It was abandoned in the middle of the nineteenth century after it was shown that there is no such thing as the caloric.

**1-5C** The *rating* problems deal with the determination of the *heat transfer rate* for an existing system at a specified temperature difference. The *sizing* problems deal with the determination of the *size* of a system in order to transfer heat at a *specified rate* for a *specified temperature difference*.

**1-6C** The experimental approach (testing and taking measurements) has the advantage of dealing with the actual physical system, and getting a physical value within the limits of experimental error. However, this approach is expensive, time consuming, and often impractical. The analytical approach (analysis or calculations) has the advantage that it is fast and inexpensive, but the results obtained are subject to the accuracy of the assumptions and idealizations made in the analysis.

**1-7C** Modeling makes it possible to predict the course of an event before it actually occurs, or to study various aspects of an event mathematically without actually running expensive and time-consuming experiments. When preparing a mathematical model, all the variables that affect the phenomena are identified, reasonable assumptions and approximations are made, and the interdependence of these variables are studied. The relevant physical laws and principles are invoked, and the problem is formulated mathematically. Finally, the problem is solved using an appropriate approach, and the results are interpreted.

**1-8C** The right choice between a crude and complex model is usually the *simplest* model which yields *adequate* results.

Preparing very accurate but complex models is not necessarily a better choice since such models are not much use to an analyst if they are very difficult and time consuming to solve. At the minimum, the model should reflect the essential features of the physical problem it represents.

**1-9C** Warmer. Because energy is added to the room air in the form of electrical work.

**1-10C** Warmer. If we take the room that contains the refrigerator as our system, we will see that electrical work is supplied to this room to run the refrigerator, which is eventually dissipated to the room as waste heat.

**1-11C** The rate of heat transfer per unit surface area is called heat flux  $\dot{q}$ . It is related to the rate of heat transfer by

$$\dot{Q} = \int_A \dot{q} dA .$$

**1-12C** Energy can be transferred by heat, work, and mass. An energy transfer is heat transfer when its driving force is temperature difference.

**1-13C** Thermal energy is the sensible and latent forms of internal energy, and it is referred to as heat in daily life.

**1-14C** For the constant pressure case. This is because the heat transfer to an ideal gas is  $mc_p\Delta T$  at constant pressure and  $mc_v\Delta T$  at constant volume, and  $c_p$  is always greater than  $c_v$ .

**1-15** A cylindrical resistor on a circuit board dissipates 1.2 W of power. The amount of heat dissipated in 24 h, the heat flux, and the fraction of heat dissipated from the top and bottom surfaces are to be determined.

**Assumptions** Heat is transferred uniformly from all surfaces.

**Analysis** (a) The amount of heat this resistor dissipates during a 24-hour period is

$$Q = \dot{Q}\Delta t = (1.2 \text{ W})(24 \text{ h}) = \mathbf{28.8 \text{ Wh} = 104 \text{ kJ}} \quad (\text{since } 1 \text{ Wh} = 3600 \text{ Ws} = 3.6 \text{ kJ})$$

(b) The heat flux on the surface of the resistor is

$$A_s = 2 \frac{\pi D^2}{4} + \pi DL = 2 \frac{\pi(0.4 \text{ cm})^2}{4} + \pi(0.4 \text{ cm})(2 \text{ cm}) = 0.251 + 2.513 = 2.764 \text{ cm}^2$$

$$\dot{q}_s = \frac{\dot{Q}}{A_s} = \frac{1.2 \text{ W}}{2.764 \text{ cm}^2} = \mathbf{0.434 \text{ W/cm}^2}$$

(c) Assuming the heat transfer coefficient to be uniform, heat transfer is proportional to the surface area. Then the fraction of heat dissipated from the top and bottom surfaces of the resistor becomes

$$\frac{Q_{\text{top-base}}}{Q_{\text{total}}} = \frac{A_{\text{top-base}}}{A_{\text{total}}} = \frac{0.251}{2.764} = \mathbf{0.091} \quad \text{or } (9.1\%)$$

**Discussion** Heat transfer from the top and bottom surfaces is small relative to that transferred from the side surface.

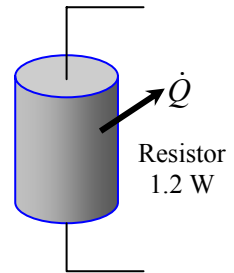

**1-16E** A logic chip in a computer dissipates 3 W of power. The amount heat dissipated in 8 h and the heat flux on the surface of the chip are to be determined.

**Assumptions** Heat transfer from the surface is uniform.

**Analysis** (a) The amount of heat the chip dissipates during an 8-hour period is

$$Q = \dot{Q}\Delta t = (3 \text{ W})(8 \text{ h}) = 24 \text{ Wh} = \mathbf{0.024 \text{ kWh}}$$

(b) The heat flux on the surface of the chip is

$$\dot{q} = \frac{\dot{Q}}{A} = \frac{3 \text{ W}}{0.08 \text{ in}^2} = \mathbf{37.5 \text{ W/in}^2}$$

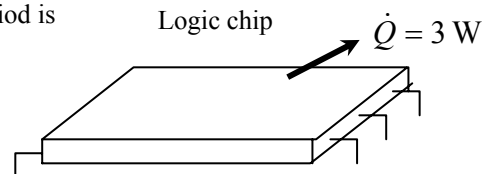

**1-17** A house is heated from 10°C to 22°C by an electric heater, and some air escapes through the cracks as the heated air in the house expands at constant pressure. The amount of heat transfer to the air and its cost are to be determined.

**Assumptions 1** Air as an ideal gas with a constant specific heats at room temperature. **2** The volume occupied by the furniture and other belongings is negligible. **3** The pressure in the house remains constant at all times. **4** Heat loss from the house to the outdoors is negligible during heating. **5** The air leaks out at 22°C.

**Properties** The specific heat of air at room temperature is  $c_p = 1.007 \text{ kJ/kg}\cdot^\circ\text{C}$ .

**Analysis** The volume and mass of the air in the house are

$$V = (\text{floor space})(\text{height}) = (200 \text{ m}^2)(3 \text{ m}) = 600 \text{ m}^3$$

$$m = \frac{PV}{RT} = \frac{(101.3 \text{ kPa})(600 \text{ m}^3)}{(0.287 \text{ kPa}\cdot\text{m}^3/\text{kg}\cdot\text{K})(10 + 273.15 \text{ K})} = 747.9 \text{ kg}$$

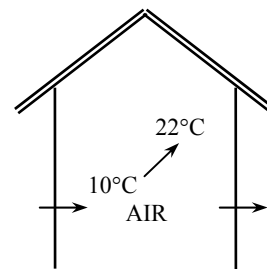

Noting that the pressure in the house remains constant during heating, the amount of heat that must be transferred to the air in the house as it is heated from 10 to 22°C is determined to be

$$Q = mc_p(T_2 - T_1) = (747.9 \text{ kg})(1.007 \text{ kJ/kg}\cdot^\circ\text{C})(22 - 10)^\circ\text{C} = \mathbf{9038 \text{ kJ}}$$

Noting that 1 kWh = 3600 kJ, the cost of this electrical energy at a unit cost of \$0.075/kWh is

$$\text{Energy Cost} = (\text{Energy used})(\text{Unit cost of energy}) = (9038 / 3600 \text{ kWh})(\$0.075/\text{kWh}) = \mathbf{\$0.19}$$

Therefore, it will cost the homeowner about 19 cents to raise the temperature in his house from 10 to 22°C.

**1-18** A 800 W iron is left on the ironing board with its base exposed to the air. The amount of heat the iron dissipates in 2 h, the heat flux on the surface of the iron base, and the cost of the electricity are to be determined.

**Assumptions** Heat transfer from the surface is uniform.

**Analysis (a)** The amount of heat the iron dissipates during a 2-h period is

$$Q = \dot{Q}\Delta t = (0.8 \text{ kW})(2 \text{ h}) = \mathbf{1.6 \text{ kWh}}$$

**(b)** The heat flux on the surface of the iron base is

$$\dot{Q}_{\text{base}} = (0.85)(800 \text{ W}) = 680 \text{ W}$$

$$\dot{q} = \frac{\dot{Q}_{\text{base}}}{A_{\text{base}}} = \frac{680 \text{ W}}{0.015 \text{ m}^2} = \mathbf{45,300 \text{ W/m}^2}$$

**(c)** The cost of electricity consumed during this period is

$$\text{Cost of electricity} = (1.6 \text{ kWh}) \times (\$0.07/\text{kWh}) = \mathbf{\$0.112}$$

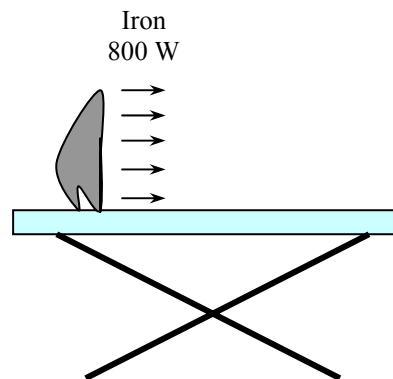

**1-19** A 15 cm × 20 cm circuit board houses 120 closely spaced 0.12 W logic chips. The amount of heat dissipated in 10 h and the heat flux on the surface of the circuit board are to be determined.

**Assumptions 1** Heat transfer from the back surface of the board is negligible. **2** Heat transfer from the front surface is uniform.

**Analysis (a)** The amount of heat this circuit board dissipates during a 10-h period is

$$\dot{Q} = (120)(0.12 \text{ W}) = 14.4 \text{ W}$$

$$Q = \dot{Q}\Delta t = (0.0144 \text{ kW})(10 \text{ h}) = \mathbf{0.144 \text{ kWh}}$$

**(b)** The heat flux on the surface of the circuit board is

$$A_s = (0.15 \text{ m})(0.2 \text{ m}) = 0.03 \text{ m}^2$$

$$\dot{q}_s = \frac{\dot{Q}}{A_s} = \frac{14.4 \text{ W}}{0.03 \text{ m}^2} = \mathbf{480 \text{ W/m}^2}$$

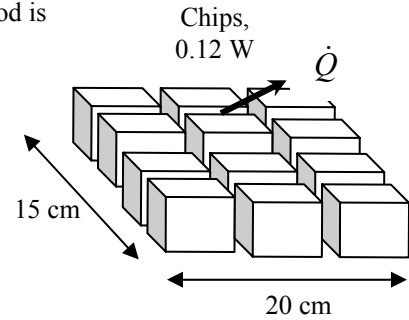

**1-20** An aluminum ball is to be heated from 80°C to 200°C. The amount of heat that needs to be transferred to the aluminum ball is to be determined.

**Assumptions** The properties of the aluminum ball are constant.

**Properties** The average density and specific heat of aluminum are given to be  $\rho = 2700 \text{ kg/m}^3$  and  $c_p = 0.90 \text{ kJ/kg}\cdot^\circ\text{C}$ .

**Analysis** The amount of energy added to the ball is simply the change in its internal energy, and is determined from

$$E_{\text{transfer}} = \Delta U = mc_p(T_2 - T_1)$$

where

$$m = \rho V = \frac{\pi}{6} \rho D^3 = \frac{\pi}{6} (2700 \text{ kg/m}^3)(0.15 \text{ m})^3 = 4.77 \text{ kg}$$

Substituting,

$$E_{\text{transfer}} = (4.77 \text{ kg})(0.90 \text{ kJ/kg}\cdot^\circ\text{C})(200 - 80)^\circ\text{C} = \mathbf{515 \text{ kJ}}$$

Therefore, 515 kJ of energy (heat or work such as electrical energy) needs to be transferred to the aluminum ball to heat it to 200°C.

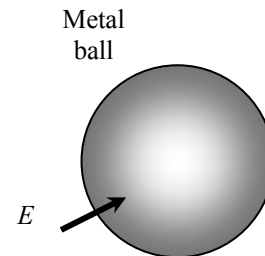

**1-21** An electrically heated house maintained at 22°C experiences infiltration losses at a rate of 0.7 ACH. The amount of energy loss from the house due to infiltration per day and its cost are to be determined.

**Assumptions 1** Air as an ideal gas with a constant specific heats at room temperature. **2** The volume occupied by the furniture and other belongings is negligible. **3** The house is maintained at a constant temperature and pressure at all times. **4** The infiltrating air exfiltrates at the indoors temperature of 22°C.

**Properties** The specific heat of air at room temperature is  $c_p = 1.007 \text{ kJ/kg}\cdot^\circ\text{C}$ .

**Analysis** The volume of the air in the house is

$$V = (\text{floor space})(\text{height}) = (150 \text{ m}^2)(3 \text{ m}) = 450 \text{ m}^3$$

Noting that the infiltration rate is 0.7 ACH (air changes per hour) and thus the air in the house is completely replaced by the outdoor air  $0.7 \times 24 = 16.8$  times per day, the mass flow rate of air through the house due to infiltration is

$$\begin{aligned} \dot{m}_{\text{air}} &= \frac{P_o \dot{V}_{\text{air}}}{RT_o} = \frac{P_o (\text{ACH} \times V_{\text{house}})}{RT_o} \\ &= \frac{(89.6 \text{ kPa})(16.8 \times 450 \text{ m}^3 / \text{day})}{(0.287 \text{ kPa} \cdot \text{m}^3 / \text{kg} \cdot \text{K})(5 + 273.15 \text{ K})} = 8485 \text{ kg/day} \end{aligned}$$

Noting that outdoor air enters at 5°C and leaves at 22°C, the energy loss of this house per day is

$$\begin{aligned} \dot{Q}_{\text{infiltr}} &= \dot{m}_{\text{air}} c_p (T_{\text{indoors}} - T_{\text{outdoors}}) \\ &= (8485 \text{ kg/day})(1.007 \text{ kJ/kg}\cdot^\circ\text{C})(22 - 5)^\circ\text{C} = 145,260 \text{ kJ/day} = \mathbf{40.4 \text{ kWh/day}} \end{aligned}$$

At a unit cost of \$0.082/kWh, the cost of this electrical energy lost by infiltration is

$$\text{Energy Cost} = (\text{Energy used})(\text{Unit cost of energy}) = (40.4 \text{ kWh/day})(\$0.082/\text{kWh}) = \mathbf{\$3.31/\text{day}}$$

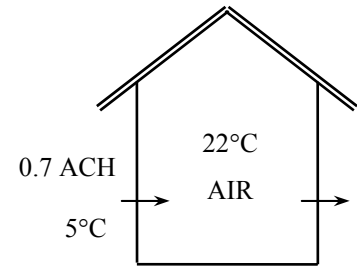

**1-22** The filament of a 150 W incandescent lamp is 5 cm long and has a diameter of 0.5 mm. The heat flux on the surface of the filament, the heat flux on the surface of the glass bulb, and the annual electricity cost of the bulb are to be determined.

**Assumptions** Heat transfer from the surface of the filament and the bulb of the lamp is uniform.

**Analysis (a)** The heat transfer surface area and the heat flux on the surface of the filament are

$$\begin{aligned} A_s &= \pi DL = \pi(0.05 \text{ cm})(5 \text{ cm}) = 0.785 \text{ cm}^2 \\ \dot{q}_s &= \frac{\dot{Q}}{A_s} = \frac{150 \text{ W}}{0.785 \text{ cm}^2} = 191 \text{ W/cm}^2 = \mathbf{1.91 \times 10^6 \text{ W/m}^2} \end{aligned}$$

(b) The heat flux on the surface of glass bulb is

$$\begin{aligned} A_s &= \pi D^2 = \pi(8 \text{ cm})^2 = 201.1 \text{ cm}^2 \\ \dot{q}_s &= \frac{\dot{Q}}{A_s} = \frac{150 \text{ W}}{201.1 \text{ cm}^2} = 0.75 \text{ W/cm}^2 = \mathbf{7500 \text{ W/m}^2} \end{aligned}$$

(c) The amount and cost of electrical energy consumed during a one-year period is

$$\begin{aligned} \text{Electricity Consumption} &= \dot{Q} \Delta t = (0.15 \text{ kW})(365 \times 8 \text{ h/yr}) = 438 \text{ kWh/yr} \\ \text{Annual Cost} &= (438 \text{ kWh/yr})(\$0.08 / \text{kWh}) = \mathbf{\$35.04/\text{yr}} \end{aligned}$$

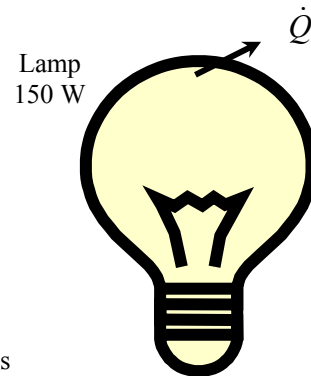

**1-23** Water is heated in an insulated tube by an electric resistance heater. The mass flow rate of water through the heater is to be determined.

**Assumptions** **1** Water is an incompressible substance with a constant specific heat. **2** The kinetic and potential energy changes are negligible,  $\Delta ke \cong \Delta pe \cong 0$ . **3** Heat loss from the insulated tube is negligible.

**Properties** The specific heat of water at room temperature is  $c_p = 4.18 \text{ kJ/kg}\cdot^\circ\text{C}$ .

**Analysis** We take the tube as the system. This is a *control volume* since mass crosses the system boundary during the process. We *observe* that this is a steady-flow process since there is no change with time at any point and thus  $\Delta m_{CV} = 0$  and  $\Delta E_{CV} = 0$ , there is only one inlet and one exit and thus  $\dot{m}_1 = \dot{m}_2 = \dot{m}$ , and the tube is insulated. The energy balance for this steady-flow system can be expressed in the rate form as

$$\underbrace{\dot{E}_{in} - \dot{E}_{out}}_{\text{Rate of net energy transfer by heat, work, and mass}} = \underbrace{\Delta \dot{E}_{\text{system}}^{\text{no (steady)}}}_{\text{Rate of change in internal, kinetic, potential, etc. energies}} = 0 \rightarrow \dot{E}_{in} = \dot{E}_{out}$$

$$\dot{W}_{e,in} + \dot{m}h_1 = \dot{m}h_2 \quad (\text{since } \Delta ke \cong \Delta pe \cong 0)$$

$$\dot{W}_{e,in} = \dot{m}c_p(T_2 - T_1)$$

Thus,

$$\dot{m} = \frac{\dot{W}_{e,in}}{c_p(T_2 - T_1)} = \frac{5 \text{ kJ/s}}{(4.18 \text{ kJ/kg}\cdot^\circ\text{C})(60 - 15)^\circ\text{C}} = \mathbf{0.0266 \text{ kg/s}}$$

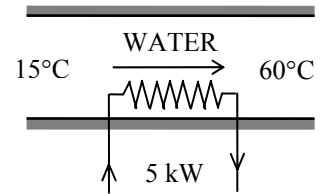



**1-24** A resistance heater is to raise the air temperature in the room from 7 to 25°C within 15 min. The required power rating of the resistance heater is to be determined.

**Assumptions** **1** Air is an ideal gas since it is at a high temperature and low pressure relative to its critical point values of -141°C and 3.77 MPa. **2** The kinetic and potential energy changes are negligible,  $\Delta ke \cong \Delta pe \cong 0$ . **3** Constant specific heats at room temperature can be used for air. This assumption results in negligible error in heating and air-conditioning applications. **4** Heat losses from the room are negligible.

**Properties** The gas constant of air is  $R = 0.287 \text{ kPa}\cdot\text{m}^3/\text{kg}\cdot\text{K}$  (Table A-1). Also,  $c_p = 1.007 \text{ kJ/kg}\cdot\text{K}$  for air at room temperature (Table A-15).

**Analysis** We observe that the pressure in the room remains constant during this process. Therefore, some air will leak out as the air expands. However, we can take the air to be a closed system by considering the air in the room to have undergone a constant pressure expansion process. The energy balance for this steady-flow system can be expressed as

$$\underbrace{E_{in} - E_{out}}_{\text{Net energy transfer by heat, work, and mass}} = \underbrace{\Delta E_{\text{system}}}_{\text{Change in internal, kinetic, potential, etc. energies}}$$

$$W_{e,in} - W_b = \Delta U$$

$$W_{e,in} = \Delta H = m(h_2 - h_1) \cong mc_p(T_2 - T_1)$$

or  $\dot{W}_{e,in} \Delta t = mc_{p,avg}(T_2 - T_1)$

The mass of air is

$$\mathcal{V} = 4 \times 5 \times 6 = 120 \text{ m}^3$$

$$m = \frac{P_1 \mathcal{V}}{RT_1} = \frac{(100 \text{ kPa})(120 \text{ m}^3)}{(0.287 \text{ kPa}\cdot\text{m}^3/\text{kg}\cdot\text{K})(280 \text{ K})} = 149.3 \text{ kg}$$

Using  $c_p$  value at room temperature, the power rating of the heater becomes

$$\dot{W}_{e,in} = (149.3 \text{ kg})(1.007 \text{ kJ/kg}\cdot^\circ\text{C})(25 - 7)^\circ\text{C}/(15 \times 60 \text{ s}) = \mathbf{3.01 \text{ kW}}$$

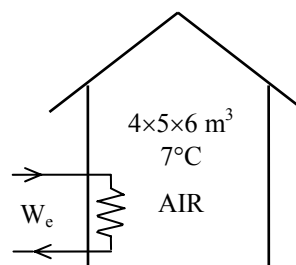

**1-25** Liquid water is to be heated in an electric teapot. The heating time is to be determined.

**Assumptions 1** Heat loss from the teapot is negligible. **2** Constant properties can be used for both the teapot and the water.

**Properties** The average specific heats are given to be 0.7 kJ/kg·K for the teapot and 4.18 kJ/kg·K for water.

**Analysis** We take the teapot and the water in it as the system, which is a closed system (fixed mass). The energy balance in this case can be expressed as

$$\underbrace{E_{in} - E_{out}}_{\text{Net energy transfer by heat, work, and mass}} = \underbrace{\Delta E_{\text{system}}}_{\text{Change in internal, kinetic, potential, etc. energies}}$$

$$E_{in} = \Delta U_{\text{system}} = \Delta U_{\text{water}} + \Delta U_{\text{teapot}}$$

Then the amount of energy needed to raise the temperature of water and the teapot from 15°C to 95°C is

$$\begin{aligned} E_{in} &= (mc\Delta T)_{\text{water}} + (mc\Delta T)_{\text{teapot}} \\ &= (1.2 \text{ kg})(4.18 \text{ kJ/kg} \cdot ^\circ\text{C})(95 - 15)^\circ\text{C} + (0.5 \text{ kg})(0.7 \text{ kJ/kg} \cdot ^\circ\text{C})(95 - 15)^\circ\text{C} \\ &= 429.3 \text{ kJ} \end{aligned}$$

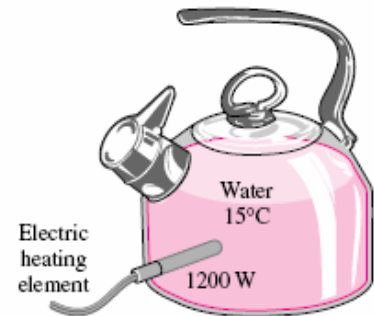

The 1200-W electric heating unit will supply energy at a rate of 1.2 kW or 1.2 kJ per second. Therefore, the time needed for this heater to supply 429.3 kJ of heat is determined from

$$\Delta t = \frac{\text{Total energy transferred}}{\text{Rate of energy transfer}} = \frac{E_{in}}{\dot{E}_{\text{transfer}}} = \frac{429.3 \text{ kJ}}{1.2 \text{ kJ/s}} = 358 \text{ s} = \mathbf{6.0 \text{ min}}$$

**Discussion** In reality, it will take more than 6 minutes to accomplish this heating process since some heat loss is inevitable during heating. Also, the specific heat units kJ/kg · °C and kJ/kg · K are equivalent, and can be interchanged.

**1-26** It is observed that the air temperature in a room heated by electric baseboard heaters remains constant even though the heater operates continuously when the heat losses from the room amount to 9000 kJ/h. The power rating of the heater is to be determined.

**Assumptions 1** Air is an ideal gas since it is at a high temperature and low pressure relative to its critical point values of -141°C and 3.77 MPa. **2** The kinetic and potential energy changes are negligible,  $\Delta ke \cong \Delta pe \cong 0$ . **3** The temperature of the room remains constant during this process.

**Analysis** We take the room as the system. The energy balance in this case reduces to

$$\underbrace{E_{in} - E_{out}}_{\text{Net energy transfer by heat, work, and mass}} = \underbrace{\Delta E_{\text{system}}}_{\text{Change in internal, kinetic, potential, etc. energies}}$$

$$W_{e,in} - Q_{out} = \Delta U = 0$$

$$W_{e,in} = Q_{out}$$

since  $\Delta U = mc\Delta T = 0$  for isothermal processes of ideal gases. Thus,

$$\dot{W}_{e,in} = \dot{Q}_{out} = 9000 \text{ kJ/h} \left( \frac{1 \text{ kW}}{3600 \text{ kJ/h}} \right) = \mathbf{2.5 \text{ kW}}$$

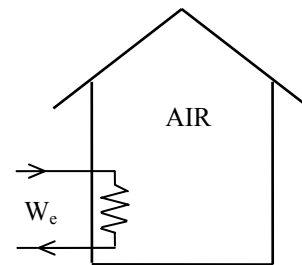

**1-27** A room is heated by an electrical resistance heater placed in a short duct in the room in 15 min while the room is losing heat to the outside, and a 300-W fan circulates the air steadily through the heater duct. The power rating of the electric heater and the temperature rise of air in the duct are to be determined.

**Assumptions 1** Air is an ideal gas since it is at a high temperature and low pressure relative to its critical point values of  $-141^{\circ}\text{C}$  and  $3.77\text{ MPa}$ . **2** The kinetic and potential energy changes are negligible,  $\Delta ke \cong \Delta pe \cong 0$ . **3** Constant specific heats at room temperature can be used for air. This assumption results in negligible error in heating and air-conditioning applications. **3** Heat loss from the duct is negligible. **4** The house is air-tight and thus no air is leaking in or out of the room.

**Properties** The gas constant of air is  $R = 0.287\text{ kPa}\cdot\text{m}^3/\text{kg}\cdot\text{K}$  (Table A-1). Also,  $c_p = 1.007\text{ kJ/kg}\cdot\text{K}$  for air at room temperature (Table A-15) and  $c_v = c_p - R = 0.720\text{ kJ/kg}\cdot\text{K}$ .

**Analysis (a)** We first take the air in the room as the system. This is a constant volume *closed system* since no mass crosses the system boundary. The energy balance for the room can be expressed as

$$\underbrace{E_{in} - E_{out}}_{\substack{\text{Net energy transfer} \\ \text{by heat, work, and mass}}} = \underbrace{\Delta E_{\text{system}}}_{\substack{\text{Change in internal, kinetic,} \\ \text{potential, etc. energies}}}$$

$$W_{e,in} + W_{fan,in} - Q_{out} = \Delta U$$

$$(\dot{W}_{e,in} + \dot{W}_{fan,in} - \dot{Q}_{out})\Delta t = m(u_2 - u_1) \cong mc_v(T_2 - T_1)$$

The total mass of air in the room is

$$V = 5 \times 6 \times 8\text{ m}^3 = 240\text{ m}^3$$

$$m = \frac{P_1 V}{RT_1} = \frac{(98\text{ kPa})(240\text{ m}^3)}{(0.287\text{ kPa}\cdot\text{m}^3/\text{kg}\cdot\text{K})(288\text{ K})} = 284.6\text{ kg}$$

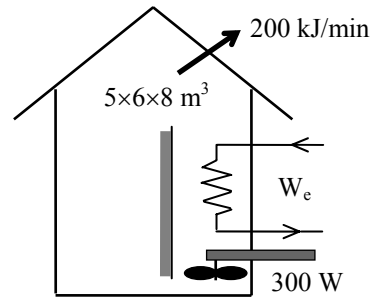

Then the power rating of the electric heater is determined to be

$$\dot{W}_{e,in} = \dot{Q}_{out} - \dot{W}_{fan,in} + mc_v(T_2 - T_1) / \Delta t$$

$$= (200/60\text{ kJ/s}) - (0.3\text{ kJ/s}) + (284.6\text{ kg})(0.720\text{ kJ/kg}\cdot^{\circ}\text{C})(25 - 15^{\circ}\text{C}) / (18 \times 60\text{ s}) = \mathbf{4.93\text{ kW}}$$

(b) The temperature rise that the air experiences each time it passes through the heater is determined by applying the energy balance to the duct,

$$\dot{E}_{in} = \dot{E}_{out}$$

$$\dot{W}_{e,in} + \dot{W}_{fan,in} + \dot{m}h_1 = \dot{Q}_{out} + \dot{m}h_2 \quad (\text{since } \Delta ke \cong \Delta pe \cong 0)$$

$$\dot{W}_{e,in} + \dot{W}_{fan,in} = \dot{m}\Delta h = \dot{m}c_p\Delta T$$

Thus,

$$\Delta T = \frac{\dot{W}_{e,in} + \dot{W}_{fan,in}}{\dot{m}c_p} = \frac{(4.93 + 0.3)\text{ kJ/s}}{(50/60\text{ kg/s})(1.007\text{ kJ/kg}\cdot\text{K})} = \mathbf{6.2^{\circ}\text{C}}$$

**1-28** The resistance heating element of an electrically heated house is placed in a duct. The air is moved by a fan, and heat is lost through the walls of the duct. The power rating of the electric resistance heater is to be determined.

**Assumptions 1** Air is an ideal gas since it is at a high temperature and low pressure relative to its critical point values of  $-141^{\circ}\text{C}$  and  $3.77\text{ MPa}$ . **2** The kinetic and potential energy changes are negligible,  $\Delta ke \cong \Delta pe \cong 0$ . **3** Constant specific heats at room temperature can be used for air. This assumption results in negligible error in heating and air-conditioning applications.

**Properties** The specific heat of air at room temperature is  $c_p = 1.007\text{ kJ/kg}\cdot^{\circ}\text{C}$  (Table A-15).

**Analysis** We take the heating duct as the system. This is a *control volume* since mass crosses the system boundary during the process. We observe that this is a steady-flow process since there is no change with time at any point and thus  $\Delta m_{CV} = 0$  and  $\Delta E_{CV} = 0$ . Also, there is only one inlet and one exit and thus  $\dot{m}_1 = \dot{m}_2 = \dot{m}$ . The energy balance for this steady-flow system can be expressed in the rate form as

$$\underbrace{\dot{E}_{in} - \dot{E}_{out}}_{\text{Rate of net energy transfer by heat, work, and mass}} = \underbrace{\Delta \dot{E}_{\text{system}}}_{\text{Rate of change in internal, kinetic, potential, etc. energies}} \stackrel{\text{no (steady)}}{=} 0 \rightarrow \dot{E}_{in} = \dot{E}_{out}$$

$$\dot{W}_{e,in} + \dot{W}_{fan,in} + \dot{m}h_1 = \dot{Q}_{out} + \dot{m}h_2 \quad (\text{since } \Delta ke \cong \Delta pe \cong 0)$$

$$\dot{W}_{e,in} = \dot{Q}_{out} - \dot{W}_{fan,in} + \dot{m}c_p(T_2 - T_1)$$

Substituting, the power rating of the heating element is determined to be

$$\begin{aligned} \dot{W}_{e,in} &= (0.25\text{ kW}) - (0.3\text{ kW}) + (0.6\text{ kg/s})(1.007\text{ kJ/kg}\cdot^{\circ}\text{C})(5^{\circ}\text{C}) \\ &= \mathbf{2.97\text{ kW}} \end{aligned}$$

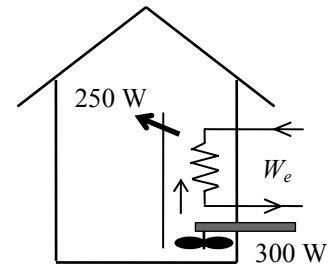

**1-29** Air is moved through the resistance heaters in a 900-W hair dryer by a fan. The volume flow rate of air at the inlet and the velocity of the air at the exit are to be determined.

**Assumptions 1** Air is an ideal gas since it is at a high temperature and low pressure relative to its critical point values of  $-141^\circ\text{C}$  and  $3.77\text{ MPa}$ . **2** The kinetic and potential energy changes are negligible,  $\Delta ke \cong \Delta pe \cong 0$ . **3** Constant specific heats at room temperature can be used for air. **4** The power consumed by the fan and the heat losses through the walls of the hair dryer are negligible.

**Properties** The gas constant of air is  $R = 0.287\text{ kPa}\cdot\text{m}^3/\text{kg}\cdot\text{K}$  (Table A-1). Also,  $c_p = 1.007\text{ kJ/kg}\cdot\text{K}$  for air at room temperature (Table A-15).

**Analysis (a)** We take the hair dryer as the system. This is a *control volume* since mass crosses the system boundary during the process. We observe that this is a steady-flow process since there is no change with time at any point and thus  $\Delta m_{CV} = 0$  and  $\Delta E_{CV} = 0$ , and there is only one inlet and one exit and thus  $\dot{m}_1 = \dot{m}_2 = \dot{m}$ . The energy balance for this steady-flow system can be expressed in the rate form as

$$\underbrace{\dot{E}_{in} - \dot{E}_{out}}_{\text{Rate of net energy transfer by heat, work, and mass}} = \underbrace{\dot{\Delta E}_{\text{system}}^{\text{0 (steady)}}}_{\text{Rate of change in internal, kinetic, potential, etc. energies}} = 0 \rightarrow \dot{E}_{in} = \dot{E}_{out}$$

$$\dot{W}_{e,in} + \dot{W}_{\text{fan,in}}^{\text{0}} + \dot{m}h_1 = \dot{Q}_{out}^{\text{0}} + \dot{m}h_2 \quad (\text{since } \Delta ke \cong \Delta pe \cong 0)$$

$$\dot{W}_{e,in} = \dot{m}c_p(T_2 - T_1)$$

Thus,

$$\dot{m} = \frac{\dot{W}_{e,in}}{c_p(T_2 - T_1)}$$

$$= \frac{0.9\text{ kJ/s}}{(1.007\text{ kJ/kg}\cdot^\circ\text{C})(50 - 25)^\circ\text{C}} = 0.03575\text{ kg/s}$$

Then,

$$\nu_1 = \frac{RT_1}{P_1} = \frac{(0.287\text{ kPa}\cdot\text{m}^3/\text{kg}\cdot\text{K})(298\text{ K})}{100\text{ kPa}} = 0.8553\text{ m}^3/\text{kg}$$

$$\dot{V}_1 = \dot{m}\nu_1 = (0.03575\text{ kg/s})(0.8553\text{ m}^3/\text{kg}) = \mathbf{0.0306\text{ m}^3/\text{s}}$$

(b) The exit velocity of air is determined from the conservation of mass equation,

$$\nu_2 = \frac{RT_2}{P_2} = \frac{(0.287\text{ kPa}\cdot\text{m}^3/\text{kg}\cdot\text{K})(323\text{ K})}{100\text{ kPa}} = 0.9270\text{ m}^3/\text{kg}$$

$$\dot{m} = \frac{1}{\nu_2} A_2 V_2 \longrightarrow V_2 = \frac{\dot{m}\nu_2}{A_2} = \frac{(0.03575\text{ kg/s})(0.9270\text{ m}^3/\text{kg})}{60 \times 10^{-4}\text{ m}^2} = \mathbf{5.52\text{ m/s}}$$

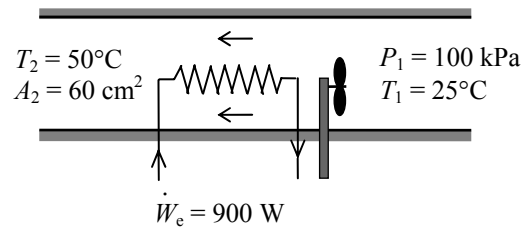

**1-30** The ducts of an air heating system pass through an unheated area, resulting in a temperature drop of the air in the duct. The rate of heat loss from the air to the cold environment is to be determined.

**Assumptions** **1** Air is an ideal gas since it is at a high temperature and low pressure relative to its critical point values of  $-141^{\circ}\text{C}$  and  $3.77\text{ MPa}$ . **2** The kinetic and potential energy changes are negligible,  $\Delta ke \cong \Delta pe \cong 0$ . **3** Constant specific heats at room temperature can be used for air. This assumption results in negligible error in heating and air-conditioning applications.

**Properties** The specific heat of air at room temperature is  $c_p = 1.007\text{ kJ/kg}\cdot^{\circ}\text{C}$  (Table A-15).

**Analysis** We take the heating duct as the system. This is a *control volume* since mass crosses the system boundary during the process. We *observe* that this is a steady-flow process since there is no change with time at any point and thus  $\Delta m_{CV} = 0$  and  $\Delta E_{CV} = 0$ . Also, there is only one inlet and one exit and thus  $\dot{m}_1 = \dot{m}_2 = \dot{m}$ . The energy balance for this steady-flow system can be expressed in the rate form as

$$\underbrace{\dot{E}_{in} - \dot{E}_{out}}_{\text{Rate of net energy transfer by heat, work, and mass}} = \underbrace{\Delta \dot{E}_{\text{system}}^{\text{no (steady)}}}_{\text{Rate of change in internal, kinetic, potential, etc. energies}} = 0 \rightarrow \dot{E}_{in} = \dot{E}_{out}$$

$$\dot{m}h_1 = \dot{Q}_{out} + \dot{m}h_2 \quad (\text{since } \Delta ke \cong \Delta pe \cong 0)$$

$$\dot{Q}_{out} = \dot{m}c_p(T_1 - T_2)$$

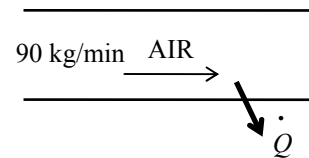

Substituting,

$$\dot{Q}_{out} = \dot{m}c_p \Delta T = (90\text{ kg/min})(1.007\text{ kJ/kg}\cdot^{\circ}\text{C})(3^{\circ}\text{C}) = \mathbf{272\text{ kJ/min}}$$

**1-31E** Air gains heat as it flows through the duct of an air-conditioning system. The velocity of the air at the duct inlet and the temperature of the air at the exit are to be determined.

**Assumptions 1** Air is an ideal gas since it is at a high temperature and low pressure relative to its critical point values of 222°F and 548 psia. **2** The kinetic and potential energy changes are negligible,  $\Delta ke \cong \Delta pe \cong 0$ . **3** Constant specific heats at room temperature can be used for air. This assumption results in negligible error in heating and air-conditioning applications.

**Properties** The gas constant of air is  $R = 0.3704 \text{ psia}\cdot\text{ft}^3/\text{lbm}\cdot\text{R}$  (Table A-1E). Also,  $c_p = 0.240 \text{ Btu}/\text{lbm}\cdot\text{R}$  for air at room temperature (Table A-15E).

**Analysis** We take the air-conditioning duct as the system. This is a *control volume* since mass crosses the system boundary during the process. We *observe* that this is a steady-flow process since there is no change with time at any point and thus  $\Delta m_{CV} = 0$  and  $\Delta E_{CV} = 0$ , there is only one inlet and one exit and thus  $\dot{m}_1 = \dot{m}_2 = \dot{m}$ , and heat is lost from the system. The energy balance for this steady-flow system can be expressed in the rate form as

$$\underbrace{\dot{E}_{in} - \dot{E}_{out}}_{\text{Rate of net energy transfer by heat, work, and mass}} = \underbrace{\Delta \dot{E}_{system}^{\text{no (steady)}}}_{\text{Rate of change in internal, kinetic, potential, etc. energies}} = 0 \rightarrow \dot{E}_{in} = \dot{E}_{out}$$

$$\dot{Q}_{in} + \dot{m}h_1 = \dot{m}h_2 \quad (\text{since } \Delta ke \cong \Delta pe \cong 0)$$

$$\dot{Q}_{in} = \dot{m}c_p(T_2 - T_1)$$

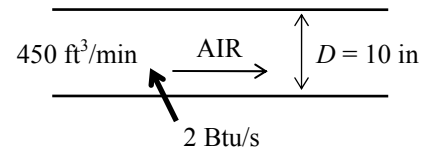

(a) The inlet velocity of air through the duct is determined from

$$V_1 = \frac{\dot{V}_1}{A_1} = \frac{\dot{V}_1}{\pi r^2} = \frac{450 \text{ ft}^3/\text{min}}{\pi(5/12 \text{ ft})^2} = \mathbf{825 \text{ ft/min}}$$

(b) The mass flow rate of air becomes

$$v_1 = \frac{RT_1}{P_1} = \frac{(0.3704 \text{ psia}\cdot\text{ft}^3/\text{lbm}\cdot\text{R})(510 \text{ R})}{15 \text{ psia}} = 12.6 \text{ ft}^3/\text{lbm}$$

$$\dot{m} = \frac{\dot{V}_1}{v_1} = \frac{450 \text{ ft}^3/\text{min}}{12.6 \text{ ft}^3/\text{lbm}} = 35.7 \text{ lbm/min} = 0.595 \text{ lbm/s}$$

Then the exit temperature of air is determined to be

$$T_2 = T_1 + \frac{\dot{Q}_{in}}{\dot{m}c_p} = 50^\circ\text{F} + \frac{2 \text{ Btu/s}}{(0.595 \text{ lbm/s})(0.240 \text{ Btu}/\text{lbm}\cdot^\circ\text{F})} = \mathbf{64.0^\circ\text{F}}$$

**1-32** A classroom is to be air-conditioned using window air-conditioning units. The cooling load is due to people, lights, and heat transfer through the walls and the windows. The number of 5-kW window air conditioning units required is to be determined.

**Assumptions** There are no heat dissipating equipment (such as computers, TVs, or ranges) in the room.

**Analysis** The total cooling load of the room is determined from

$$\dot{Q}_{\text{cooling}} = \dot{Q}_{\text{lights}} + \dot{Q}_{\text{people}} + \dot{Q}_{\text{heatgain}}$$

where

$$\dot{Q}_{\text{lights}} = 10 \times 100 \text{ W} = 1 \text{ kW}$$

$$\dot{Q}_{\text{people}} = 50 \times 360 \text{ kJ/h} = 18,000 \text{ kJ/h} = 5 \text{ kW}$$

$$\dot{Q}_{\text{heatgain}} = 12,000 \text{ kJ/h} = 3.33 \text{ kW}$$

Substituting,

$$\dot{Q}_{\text{cooling}} = 1 + 5 + 3.33 = 9.33 \text{ kW}$$

Thus the number of air-conditioning units required is

$$\frac{9.33 \text{ kW}}{5 \text{ kW/unit}} = 1.87 \longrightarrow \mathbf{2 \text{ units}}$$

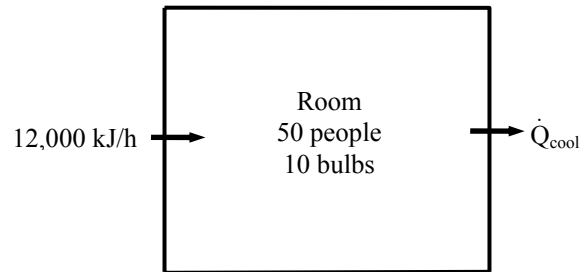



## Heat Transfer Mechanisms

**1-33C** Diamond is a better heat conductor.

**1-34C** The thermal conductivity of a material is the rate of heat transfer through a unit thickness of the material per unit area and per unit temperature difference. The thermal conductivity of a material is a measure of how fast heat will be conducted in that material.

**1-35C** The mechanisms of heat transfer are conduction, convection and radiation. Conduction is the transfer of energy from the more energetic particles of a substance to the adjacent less energetic ones as a result of interactions between the particles. Convection is the mode of energy transfer between a solid surface and the adjacent liquid or gas which is in motion, and it involves combined effects of conduction and fluid motion. Radiation is energy emitted by matter in the form of electromagnetic waves (or photons) as a result of the changes in the electronic configurations of the atoms or molecules.

**1-36C** In solids, conduction is due to the combination of the vibrations of the molecules in a lattice and the energy transport by free electrons. In gases and liquids, it is due to the collisions of the molecules during their random motion.

**1-37C** The parameters that effect the rate of heat conduction through a windowless wall are the geometry and surface area of wall, its thickness, the material of the wall, and the temperature difference across the wall.

**1-38C** Conduction is expressed by Fourier's law of conduction as  $\dot{Q}_{\text{cond}} = -kA \frac{dT}{dx}$  where  $dT/dx$  is the temperature gradient,  $k$  is the thermal conductivity, and  $A$  is the area which is normal to the direction of heat transfer.

Convection is expressed by Newton's law of cooling as  $\dot{Q}_{\text{conv}} = hA_s(T_s - T_\infty)$  where  $h$  is the convection heat transfer coefficient,  $A_s$  is the surface area through which convection heat transfer takes place,  $T_s$  is the surface temperature and  $T_\infty$  is the temperature of the fluid sufficiently far from the surface.

Radiation is expressed by Stefan-Boltzman law as  $\dot{Q}_{\text{rad}} = \varepsilon\sigma A_s(T_s^4 - T_{\text{surr}}^4)$  where  $\varepsilon$  is the emissivity of surface,  $A_s$  is the surface area,  $T_s$  is the surface temperature,  $T_{\text{surr}}$  is the average surrounding surface temperature and  $\sigma = 5.67 \times 10^{-8} \text{ W/m}^2 \cdot \text{K}^4$  is the Stefan-Boltzman constant.

**1-39C** Convection involves fluid motion, conduction does not. In a solid we can have only conduction.

**1-40C** No. It is purely by radiation.

**1-41C** In forced convection the fluid is forced to move by external means such as a fan, pump, or the wind. The fluid motion in natural convection is due to buoyancy effects only.

**1-42C** Emissivity is the ratio of the radiation emitted by a surface to the radiation emitted by a blackbody at the same temperature. Absorptivity is the fraction of radiation incident on a surface that is absorbed by the surface. The Kirchhoff's law of radiation states that the emissivity and the absorptivity of a surface are equal at the same temperature and wavelength.

**1-43C** A blackbody is an idealized body which emits the maximum amount of radiation at a given temperature and which absorbs all the radiation incident on it. Real bodies emit and absorb less radiation than a blackbody at the same temperature.

**1-44C** No. Such a definition will imply that doubling the thickness will double the heat transfer rate. The equivalent but "more correct" unit of thermal conductivity is  $\text{W}\cdot\text{m}/\text{m}^2\cdot^\circ\text{C}$  that indicates product of heat transfer rate and thickness per unit surface area per unit temperature difference.

**1-45C** In a typical house, heat loss through the wall with glass window will be larger since the glass is much thinner than a wall, and its thermal conductivity is higher than the average conductivity of a wall.

**1-46C** The house with the lower rate of heat transfer through the walls will be more energy efficient. Heat conduction is proportional to thermal conductivity (which is  $0.72 \text{ W}/\text{m}\cdot^\circ\text{C}$  for brick and  $0.17 \text{ W}/\text{m}\cdot^\circ\text{C}$  for wood, Table 1-1) and inversely proportional to thickness. The wood house is more energy efficient since the wood wall is twice as thick but it has about one-fourth the conductivity of brick wall.

**1-47C** The rate of heat transfer through both walls can be expressed as

$$\dot{Q}_{\text{wood}} = k_{\text{wood}} A \frac{T_1 - T_2}{L_{\text{wood}}} = (0.16 \text{ W}/\text{m}\cdot^\circ\text{C}) A \frac{T_1 - T_2}{0.1 \text{ m}} = 1.6A(T_1 - T_2)$$

$$\dot{Q}_{\text{brick}} = k_{\text{brick}} A \frac{T_1 - T_2}{L_{\text{brick}}} = (0.72 \text{ W}/\text{m}\cdot^\circ\text{C}) A \frac{T_1 - T_2}{0.25 \text{ m}} = 2.88A(T_1 - T_2)$$

where thermal conductivities are obtained from Table A-5. Therefore, heat transfer through the brick wall will be larger despite its higher thickness.

**1-48C** The thermal conductivity of gases is proportional to the square root of absolute temperature. The thermal conductivity of most liquids, however, decreases with increasing temperature, with water being a notable exception.

**1-49C** Superinsulations are obtained by using layers of highly reflective sheets separated by glass fibers in an evacuated space. Radiation heat transfer between two surfaces is inversely proportional to the number of sheets used and thus heat loss by radiation will be very low by using this highly reflective sheets. At the same time, evacuating the space between the layers forms a vacuum under 0.000001 atm pressure which minimize conduction or convection through the air space between the layers.

**1-50C** Most ordinary insulations are obtained by mixing fibers, powders, or flakes of insulating materials with air. Heat transfer through such insulations is by conduction through the solid material, and conduction or convection through the air space as well as radiation. Such systems are characterized by apparent thermal conductivity instead of the ordinary thermal conductivity in order to incorporate these convection and radiation effects.

**1-51C** The thermal conductivity of an alloy of two metals will most likely be less than the thermal conductivities of both metals.

**1-52** Two surfaces of a flat plate are maintained at specified temperatures, and the rate of heat transfer through the plate is measured. The thermal conductivity of the plate material is to be determined.

**Assumptions** **1** Steady operating conditions exist since the surface temperatures of the plate remain constant at the specified values. **2** Heat transfer through the plate is one-dimensional. **3** Thermal properties of the plate are constant.

**Analysis** The thermal conductivity is determined directly from the steady one-dimensional heat conduction relation to be

$$\dot{Q} = kA \frac{T_1 - T_2}{L} \rightarrow k = \frac{(\dot{Q}/A)L}{(T_1 - T_2)} = \frac{(500 \text{ W/m}^2)(0.02 \text{ m})}{(80 - 0)^\circ\text{C}} = \mathbf{0.125 \text{ W/m} \cdot ^\circ\text{C}}$$

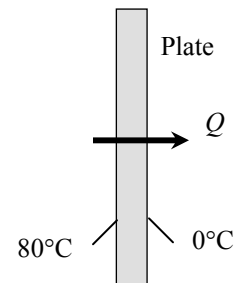

**1-53** Four power transistors are mounted on a thin vertical aluminum plate that is cooled by a fan. The temperature of the aluminum plate is to be determined.

**Assumptions** **1** Steady operating conditions exist. **2** The entire plate is nearly isothermal. **3** Thermal properties of the wall are constant. **4** The exposed surface area of the transistor can be taken to be equal to its base area. **5** Heat transfer by radiation is disregarded. **6** The convection heat transfer coefficient is constant and uniform over the surface.

**Analysis** The total rate of heat dissipation from the aluminum plate and the total heat transfer area are

$$\begin{aligned} \dot{Q} &= 4 \times 12 \text{ W} = 48 \text{ W} \\ A_s &= (0.22 \text{ m})(0.22 \text{ m}) = 0.0484 \text{ m}^2 \end{aligned}$$

Disregarding any radiation effects, the temperature of the aluminum plate is determined to be

$$\dot{Q} = hA_s(T_s - T_\infty) \rightarrow T_s = T_\infty + \frac{\dot{Q}}{hA_s} = 25^\circ\text{C} + \frac{48 \text{ W}}{(25 \text{ W/m}^2 \cdot ^\circ\text{C})(0.0484 \text{ m}^2)} = \mathbf{64.7^\circ\text{C}}$$

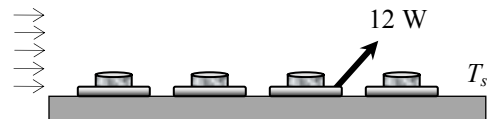

**1-54** The convection heat transfer coefficient heat transfer between the surface of a pipe carrying superheated vapor and the surrounding is to be determined.

**Assumptions** 1 Steady operating conditions exist. 2 Heat transfer by radiation is not considered. 3 Rate of heat loss from the vapor in the pipe is equal to the heat transfer rate by convection between pipe surface and the surrounding.

**Properties** The specific heat of vapor is given to be  $2190 \text{ J/kg} \cdot ^\circ\text{C}$ .

**Analysis** The surface area of the pipe is

$$A_s = \pi DL = \pi(0.05 \text{ m})(10 \text{ m}) = 1.571 \text{ m}^2$$

The rate of heat loss from the vapor in the pipe can be determined from

$$\begin{aligned}\dot{Q}_{\text{loss}} &= \dot{m}c_p(T_{\text{in}} - T_{\text{out}}) \\ &= (0.3 \text{ kg/s})(2190 \text{ J/kg} \cdot ^\circ\text{C})(30)^\circ\text{C} = 19710 \text{ J/s} \\ &= 19710 \text{ W}\end{aligned}$$

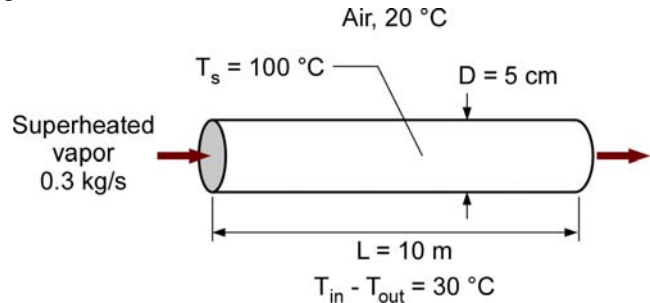

With the rate of heat loss from the vapor in the pipe assumed equal to the heat transfer rate by convection, the heat transfer coefficient can be determined using the Newton's law of cooling:

$$\dot{Q}_{\text{loss}} = \dot{Q}_{\text{conv}} = hA_s(T_s - T_\infty)$$

Rearranging, the heat transfer coefficient is determined to be

$$h = \frac{\dot{Q}_{\text{loss}}}{A_s(T_s - T_\infty)} = \frac{19710 \text{ W}}{(1.571 \text{ m}^2)(100 - 20)^\circ\text{C}} = 157 \text{ W/m}^2 \cdot ^\circ\text{C}$$

**Discussion** By insulating the pipe surface, heat loss from the vapor in the pipe can be reduced.

**1-55** An electrical resistor with a uniform temperature of  $90^\circ\text{C}$  is in a room at  $20^\circ\text{C}$ . The heat transfer coefficient by convection is to be determined.

**Assumptions** 1 Steady operating conditions exist. 2 Radiation heat transfer is negligible. 3 No hot spot exists on the resistor.

**Analysis** The total heat transfer area of the resistor is

$$A_s = 2(\pi D^2 / 4) + \pi DL = 2\pi(0.025 \text{ m})^2 / 4 + \pi(0.025 \text{ m})(0.15 \text{ m}) = 0.01276 \text{ m}^2$$

The electrical energy converted to thermal energy is transferred by convection:

$$\dot{Q}_{\text{conv}} = IV = (5 \text{ A})(6 \text{ V}) = 30 \text{ W}$$

From Newton's law of cooling, the heat transfer by convection is given as

$$\dot{Q}_{\text{conv}} = hA_s(T_s - T_\infty)$$

Rearranging, the heat transfer coefficient is determined to be

$$h = \frac{\dot{Q}_{\text{conv}}}{A_s(T_s - T_\infty)} = \frac{30 \text{ W}}{(0.01276 \text{ m}^2)(90 - 20)^\circ\text{C}} = 33.6 \text{ W/m}^2 \cdot ^\circ\text{C}$$

**Discussion** By comparing the magnitude of the heat transfer coefficient determined here with the values presented in Table 1-5, one can conclude that it is likely that forced convection is taking place rather than free convection.

**1-56** The inner and outer surfaces of a brick wall are maintained at specified temperatures. The rate of heat transfer through the wall is to be determined.

**Assumptions 1** Steady operating conditions exist since the surface temperatures of the wall remain constant at the specified values. **2** Thermal properties of the wall are constant.

**Properties** The thermal conductivity of the wall is given to be  $k = 0.69 \text{ W/m}\cdot\text{°C}$ .

**Analysis** Under steady conditions, the rate of heat transfer through the wall is

$$\dot{Q}_{\text{cond}} = kA \frac{\Delta T}{L} = (0.69 \text{ W/m}\cdot\text{°C})(4 \times 7 \text{ m}^2) \frac{(26 - 8)\text{°C}}{0.3 \text{ m}} = \mathbf{1159 \text{ W}}$$

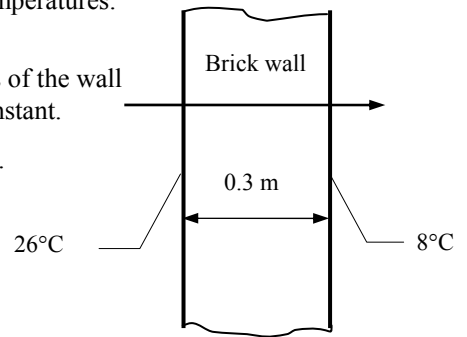

**1-57** The inner and outer surfaces of a window glass are maintained at specified temperatures. The amount of heat transfer through the glass in 5 h is to be determined.

**Assumptions 1** Steady operating conditions exist since the surface temperatures of the glass remain constant at the specified values. **2** Thermal properties of the glass are constant.

**Properties** The thermal conductivity of the glass is given to be  $k = 0.78 \text{ W/m}\cdot\text{°C}$ .

**Analysis** Under steady conditions, the rate of heat transfer through the glass by conduction is

$$\dot{Q}_{\text{cond}} = kA \frac{\Delta T}{L} = (0.78 \text{ W/m}\cdot\text{°C})(2 \times 2 \text{ m}^2) \frac{(10 - 3)\text{°C}}{0.005 \text{ m}} = 4368 \text{ W}$$

Then the amount of heat transfer over a period of 5 h becomes

$$Q = \dot{Q}_{\text{cond}} \Delta t = (4.368 \text{ kJ/s})(5 \times 3600 \text{ s}) = \mathbf{78,620 \text{ kJ}}$$

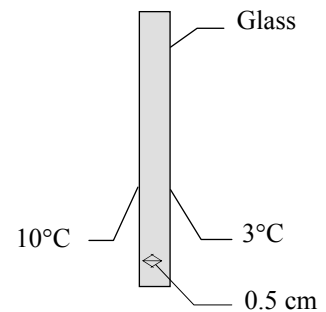

If the thickness of the glass doubled to 1 cm, then the amount of heat transfer will go down by half to **39,310 kJ**.



**1-58** Prob. 1-57 is reconsidered. The amount of heat loss through the glass as a function of the window glass thickness is to be plotted.

**Analysis** The problem is solved using EES, and the solution is given below.

**"GIVEN"**

L=0.005 [m]  
 A=2\*2 [m^2]  
 T\_1=10 [C]  
 T\_2=3 [C]  
 k=0.78 [W/m-C]  
 time=5\*3600 [s]

**"ANALYSIS"**

$Q_{\text{dot\_cond}} = k \cdot A \cdot (T_1 - T_2) / L$   
 $Q_{\text{cond}} = Q_{\text{dot\_cond}} \cdot \text{time} \cdot \text{Convert}(\text{J}, \text{kJ})$

L [m]	Q <sub>cond</sub> [kJ]
0.001	393120
0.002	196560
0.003	131040
0.004	98280
0.005	78624
0.006	65520
0.007	56160
0.008	49140
0.009	43680
0.01	39312

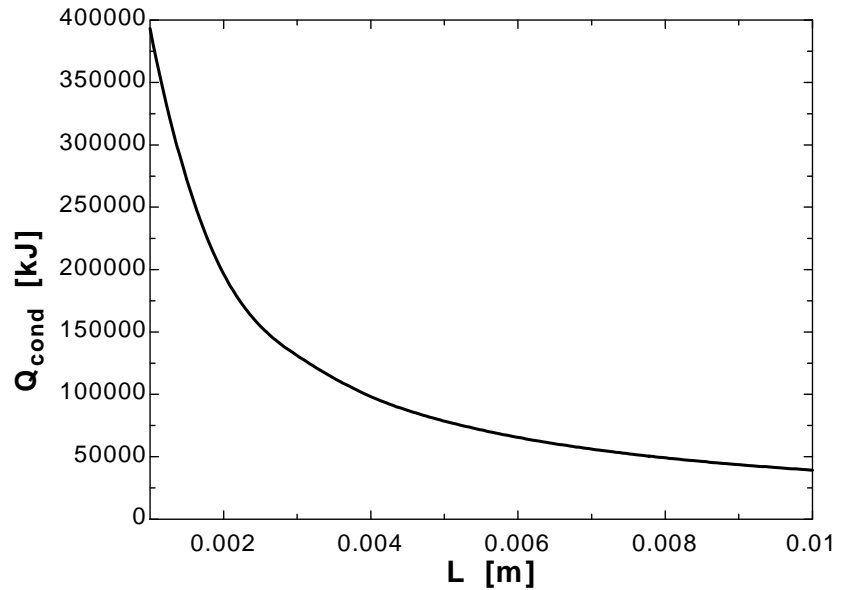

**1-59** Heat is transferred steadily to boiling water in the pan through its bottom. The inner surface temperature of the bottom of the pan is given. The temperature of the outer surface is to be determined.

**Assumptions 1** Steady operating conditions exist since the surface temperatures of the pan remain constant at the specified values. **2** Thermal properties of the aluminum pan are constant.

**Properties** The thermal conductivity of the aluminum is given to be  $k = 237 \text{ W/m}\cdot\text{C}$ .

**Analysis** The heat transfer area is

$$A = \pi r^2 = \pi (0.075 \text{ m})^2 = 0.0177 \text{ m}^2$$

Under steady conditions, the rate of heat transfer through the bottom of the pan by conduction is

$$\dot{Q} = kA \frac{\Delta T}{L} = kA \frac{T_2 - T_1}{L}$$

Substituting,

$$1400 \text{ W} = (237 \text{ W/m}\cdot\text{C})(0.0177 \text{ m}^2) \frac{T_2 - 105^\circ\text{C}}{0.004 \text{ m}}$$

which gives

$$T_2 = \mathbf{106.33^\circ\text{C}}$$

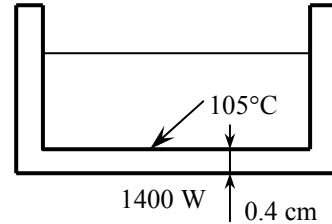

**1-60E** The inner and outer surface temperatures of the wall of an electrically heated home during a winter night are measured. The rate of heat loss through the wall that night and its cost are to be determined.

**Assumptions 1** Steady operating conditions exist since the surface temperatures of the wall remain constant at the specified values during the entire night. **2** Thermal properties of the wall are constant.

**Properties** The thermal conductivity of the brick wall is given to be  $k = 0.42 \text{ Btu/h}\cdot\text{ft}\cdot\text{F}$ .

**Analysis** (a) Noting that the heat transfer through the wall is by conduction and the surface area of the wall is  $A = 20 \text{ ft} \times 10 \text{ ft} = 200 \text{ ft}^2$ , the steady rate of heat transfer through the wall can be determined from

$$\dot{Q} = kA \frac{T_1 - T_2}{L} = (0.42 \text{ Btu/h}\cdot\text{ft}\cdot\text{F})(200 \text{ ft}^2) \frac{(62 - 25)^\circ\text{F}}{1 \text{ ft}} = \mathbf{3108 \text{ Btu/h}}$$

or 0.911 kW since  $1 \text{ kW} = 3412 \text{ Btu/h}$ .

(b) The amount of heat lost during an 8 hour period and its cost are

$$Q = \dot{Q}\Delta t = (0.911 \text{ kW})(8\text{h}) = 7.288 \text{ kWh}$$

$$\begin{aligned} \text{Cost} &= (\text{Amount of energy})(\text{Unit cost of energy}) \\ &= (7.288 \text{ kWh})(\$0.07/\text{kWh}) \\ &= \mathbf{\$0.51} \end{aligned}$$

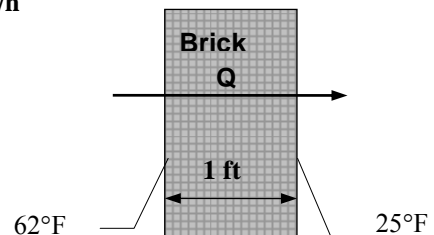

Therefore, the cost of the heat loss through the wall to the home owner that night is \$0.51.

**1-61** The thermal conductivity of a material is to be determined by ensuring one-dimensional heat conduction, and by measuring temperatures when steady operating conditions are reached.

**Assumptions 1** Steady operating conditions exist since the temperature readings do not change with time. **2** Heat losses through the lateral surfaces of the apparatus are negligible since those surfaces are well-insulated, and thus the entire heat generated by the heater is conducted through the samples. **3** The apparatus possesses thermal symmetry.

**Analysis** The electrical power consumed by the heater and converted to heat is

$$\dot{W}_e = \mathbf{VI} = (110 \text{ V})(0.6 \text{ A}) = 66 \text{ W}$$

The rate of heat flow through each sample is

$$\dot{Q} = \frac{\dot{W}_e}{2} = \frac{66 \text{ W}}{2} = 33 \text{ W}$$

Then the thermal conductivity of the sample becomes

$$A = \frac{\pi D^2}{4} = \frac{\pi(0.04 \text{ m})^2}{4} = 0.001257 \text{ m}^2$$

$$\dot{Q} = kA \frac{\Delta T}{L} \longrightarrow k = \frac{\dot{Q}L}{A\Delta T} = \frac{(33 \text{ W})(0.03 \text{ m})}{(0.001257 \text{ m}^2)(8^\circ\text{C})} = \mathbf{98.5 \text{ W/m}\cdot^\circ\text{C}}$$

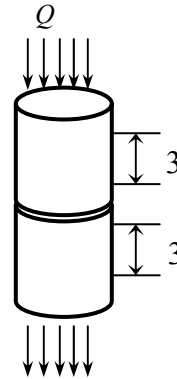

**1-62** The thermal conductivity of a material is to be determined by ensuring one-dimensional heat conduction, and by measuring temperatures when steady operating conditions are reached.

**Assumptions 1** Steady operating conditions exist since the temperature readings do not change with time. **2** Heat losses through the lateral surfaces of the apparatus are negligible since those surfaces are well-insulated, and thus the entire heat generated by the heater is conducted through the samples. **3** The apparatus possesses thermal symmetry.

**Analysis** For each sample we have

$$\dot{Q} = 25 / 2 = 12.5 \text{ W}$$

$$A = (0.1 \text{ m})(0.1 \text{ m}) = 0.01 \text{ m}^2$$

$$\Delta T = 82 - 74 = 8^\circ\text{C}$$

Then the thermal conductivity of the material becomes

$$\dot{Q} = kA \frac{\Delta T}{L} \longrightarrow k = \frac{\dot{Q}L}{A\Delta T} = \frac{(12.5 \text{ W})(0.005 \text{ m})}{(0.01 \text{ m}^2)(8^\circ\text{C})} = \mathbf{0.781 \text{ W/m}\cdot^\circ\text{C}}$$

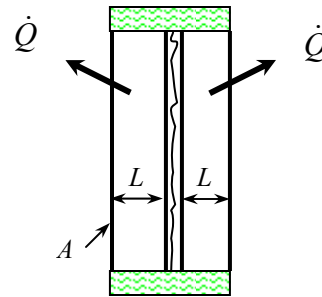



**1-63** The thermal conductivity of a material is to be determined by ensuring one-dimensional heat conduction, and by measuring temperatures when steady operating conditions are reached.

**Assumptions 1** Steady operating conditions exist since the temperature readings do not change with time. **2** Heat losses through the lateral surfaces of the apparatus are negligible since those surfaces are well-insulated, and thus the entire heat generated by the heater is conducted through the samples. **3** The apparatus possesses thermal symmetry.

**Analysis** For each sample we have

$$\dot{Q} = 20 / 2 = 10 \text{ W}$$

$$A = (0.1 \text{ m})(0.1 \text{ m}) = 0.01 \text{ m}^2$$

$$\Delta T = 82 - 74 = 8^\circ\text{C}$$

Then the thermal conductivity of the material becomes

$$\dot{Q} = kA \frac{\Delta T}{L} \longrightarrow k = \frac{\dot{Q}L}{A\Delta T} = \frac{(10 \text{ W})(0.005 \text{ m})}{(0.01 \text{ m}^2)(8^\circ\text{C})} = \mathbf{0.625 \text{ W/m} \cdot ^\circ\text{C}}$$

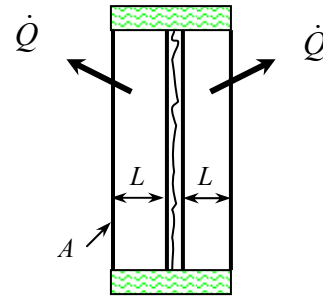

**1-64** The thermal conductivity of a refrigerator door is to be determined by measuring the surface temperatures and heat flux when steady operating conditions are reached.

**Assumptions 1** Steady operating conditions exist when measurements are taken. **2** Heat transfer through the door is one dimensional since the thickness of the door is small relative to other dimensions.

**Analysis** The thermal conductivity of the door material is determined directly from Fourier's relation to be

$$\dot{q} = k \frac{\Delta T}{L} \longrightarrow k = \frac{\dot{q}L}{\Delta T} = \frac{(32 \text{ W/m}^2)(0.03 \text{ m})}{(15 - 7)^\circ\text{C}} = \mathbf{0.120 \text{ W/m} \cdot ^\circ\text{C}}$$

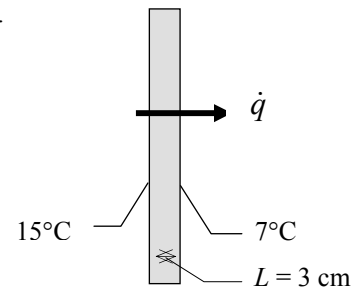

**1-65** The rate of radiation heat transfer between a person and the surrounding surfaces at specified temperatures is to be determined in summer and in winter.

**Assumptions** **1** Steady operating conditions exist. **2** Heat transfer by convection is not considered. **3** The person is completely surrounded by the interior surfaces of the room. **4** The surrounding surfaces are at a uniform temperature.

**Properties** The emissivity of a person is given to be  $\epsilon = 0.95$

**Analysis** Noting that the person is completely enclosed by the surrounding surfaces, the net rates of radiation heat transfer from the body to the surrounding walls, ceiling, and the floor in both cases are:

(a) Summer:  $T_{\text{surr}} = 23 + 273 = 296$

$$\begin{aligned}\dot{Q}_{\text{rad}} &= \epsilon \sigma A_s (T_s^4 - T_{\text{surr}}^4) \\ &= (0.95)(5.67 \times 10^{-8} \text{ W/m}^2 \cdot \text{K}^4)(1.6 \text{ m}^2)[(32 + 273)^4 - (296 \text{ K})^4] \text{ K}^4 \\ &= \mathbf{84.2 \text{ W}}\end{aligned}$$

(b) Winter:  $T_{\text{surr}} = 12 + 273 = 285 \text{ K}$

$$\begin{aligned}\dot{Q}_{\text{rad}} &= \epsilon \sigma A_s (T_s^4 - T_{\text{surr}}^4) \\ &= (0.95)(5.67 \times 10^{-8} \text{ W/m}^2 \cdot \text{K}^4)(1.6 \text{ m}^2)[(32 + 273)^4 - (285 \text{ K})^4] \text{ K}^4 \\ &= \mathbf{177.2 \text{ W}}\end{aligned}$$



**Discussion** Note that the radiation heat transfer from the person more than doubles in winter.



**1-66** Prob. 1-65 is reconsidered. The rate of radiation heat transfer in winter as a function of the temperature of the inner surface of the room is to be plotted.

**Analysis** The problem is solved using EES, and the solution is given below.

**"GIVEN"**

$$T_{\text{infinity}}=(20+273) \text{ [K]}$$

$$T_{\text{surr\_winter}}=(12+273) \text{ [K]}$$

$$T_{\text{surr\_summer}}=(23+273) \text{ [K]}$$

$$A=1.6 \text{ [m}^2\text{]}$$

$$\text{epsilon}=0.95$$

$$T_{\text{s}}=(32+273) \text{ [K]}$$

**"ANALYSIS"**

$$\text{sigma}=5.67\text{E-}8 \text{ [W/m}^2\text{-K}^4\text{]} \text{ "Stefan-Boltzman constant"}$$

$$Q_{\text{dot\_rad\_summer}}=\text{epsilon}*\text{sigma}*A*(T_{\text{s}}^4-T_{\text{surr\_summer}}^4)$$

$$Q_{\text{dot\_rad\_winter}}=\text{epsilon}*\text{sigma}*A*(T_{\text{s}}^4-T_{\text{surr\_winter}}^4)$$

$T_{\text{surr, winter}}$ [K]	$Q_{\text{rad, winter}}$ [W]
281	208.5
282	200.8
283	193
284	185.1
285	177.2
286	169.2
287	161.1
288	152.9
289	144.6
290	136.2
291	127.8

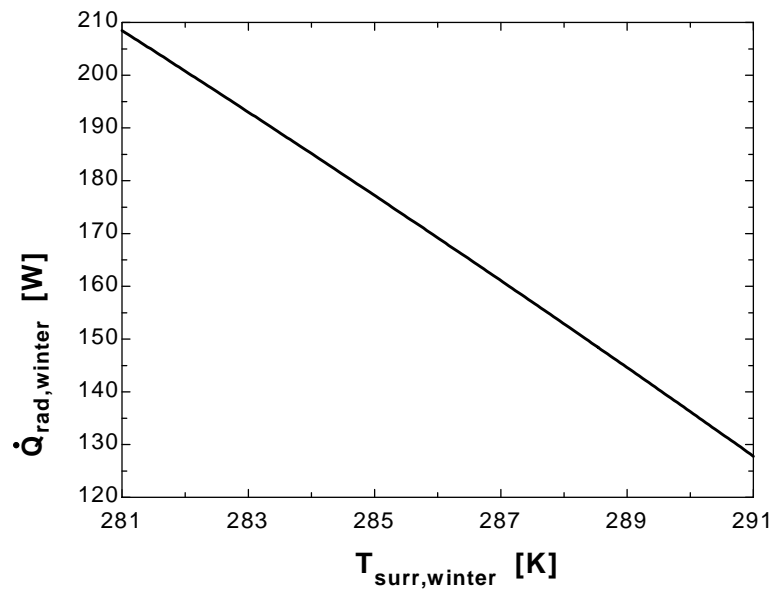

**1-67** A person is standing in a room at a specified temperature. The rate of heat transfer between a person and the surrounding air by convection is to be determined.

**Assumptions** **1** Steady operating conditions exist. **2** Heat transfer by radiation is not considered. **3** The environment is at a uniform temperature.

**Analysis** The heat transfer surface area of the person is

$$A_s = \pi DL = \pi(0.3 \text{ m})(1.70 \text{ m}) = 1.602 \text{ m}^2$$

Under steady conditions, the rate of heat transfer by convection is

$$\dot{Q}_{\text{conv}} = hA_s \Delta T = (8 \text{ W/m}^2 \cdot ^\circ\text{C})(1.602 \text{ m}^2)(34 - 18)^\circ\text{C} = \mathbf{205 \text{ W}}$$

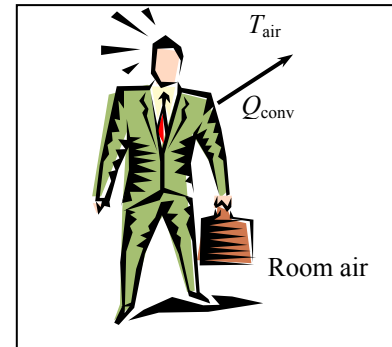

**1-68** Hot air is blown over a flat surface at a specified temperature. The rate of heat transfer from the air to the plate is to be determined.

**Assumptions** **1** Steady operating conditions exist. **2** Heat transfer by radiation is not considered. **3** The convection heat transfer coefficient is constant and uniform over the surface.

**Analysis** Under steady conditions, the rate of heat transfer by convection is

$$\dot{Q}_{\text{conv}} = hA_s \Delta T = (55 \text{ W/m}^2 \cdot ^\circ\text{C})(2 \times 4 \text{ m}^2)(80 - 30)^\circ\text{C} = \mathbf{22,000 \text{ W}}$$

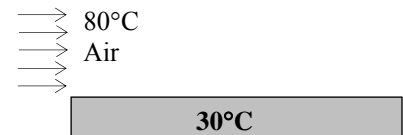



**1-69** Prob. 1-68 is reconsidered. The rate of heat transfer as a function of the heat transfer coefficient is to be plotted.

*Analysis* The problem is solved using EES, and the solution is given below.

**"GIVEN"**

$$T_{\text{infinity}}=80 \text{ [C]}$$

$$A=2*4 \text{ [m}^2\text{]}$$

$$T_s=30 \text{ [C]}$$

$$h=55 \text{ [W/m}^2\text{-C]}$$

**"ANALYSIS"**

$$Q_{\text{dot\_conv}}=h*A*(T_{\text{infinity}}-T_s)$$

h [W/m <sup>2</sup> .C]	Q <sub>conv</sub> [W]
20	8000
30	12000
40	16000
50	20000
60	24000
70	28000
80	32000
90	36000
100	40000

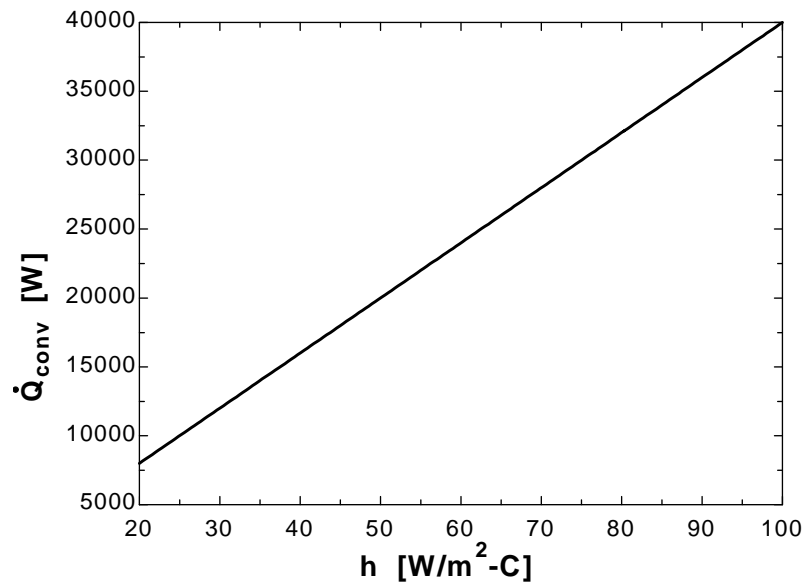

**1-70** A spacecraft in space absorbs solar radiation while losing heat to deep space by thermal radiation. The surface temperature of the spacecraft is to be determined when steady conditions are reached.

**Assumptions** 1 Steady operating conditions exist since the surface temperatures of the wall remain constant at the specified values. 2 Thermal properties of the wall are constant.

**Properties** The outer surface of a spacecraft has an emissivity of 0.8 and an absorptivity of 0.3.

**Analysis** When the heat loss from the outer surface of the spacecraft by radiation equals the solar radiation absorbed, the surface temperature can be determined from

$$\begin{aligned}\dot{Q}_{\text{solar absorbed}} &= \dot{Q}_{\text{rad}} \\ \alpha \dot{Q}_{\text{solar}} &= \varepsilon \sigma A_s (T_s^4 - T_{\text{space}}^4) \\ 0.3 \times A_s \times (950 \text{ W/m}^2) &= 0.8 \times A_s \times (5.67 \times 10^{-8} \text{ W/m}^2 \cdot \text{K}^4) [T_s^4 - (0 \text{ K})^4]\end{aligned}$$

Canceling the surface area  $A$  and solving for  $T_s$  gives

$$T_s = \mathbf{281.5 \text{ K}}$$

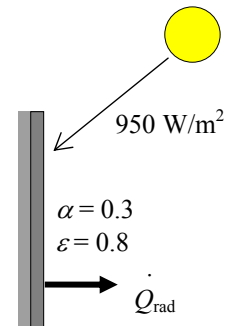

**1-71** The heat generated in the circuitry on the surface of a 5-W silicon chip is conducted to the ceramic substrate. The temperature difference across the chip in steady operation is to be determined.

**Assumptions** 1 Steady operating conditions exist. 2 Thermal properties of the chip are constant.

**Properties** The thermal conductivity of the silicon chip is given to be  $k = 130 \text{ W/m} \cdot ^\circ\text{C}$ .

**Analysis** The temperature difference between the front and back surfaces of the chip is

$$\begin{aligned}A &= (0.006 \text{ m})(0.006 \text{ m}) = 0.000036 \text{ m}^2 \\ \dot{Q} &= kA \frac{\Delta T}{L} \\ \Delta T &= \frac{\dot{Q}L}{kA} = \frac{(5 \text{ W})(0.0005 \text{ m})}{(130 \text{ W/m} \cdot ^\circ\text{C})(0.000036 \text{ m}^2)} = \mathbf{0.53^\circ\text{C}}\end{aligned}$$

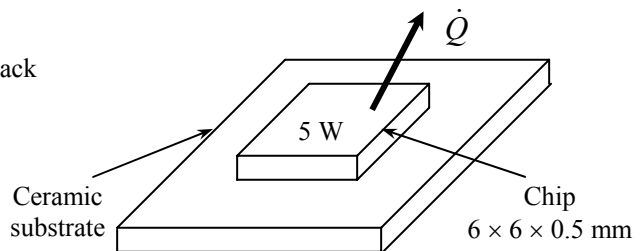

**1-72** An electric resistance heating element is immersed in water initially at 20°C. The time it will take for this heater to raise the water temperature to 80°C as well as the convection heat transfer coefficients at the beginning and at the end of the heating process are to be determined.

**Assumptions 1** Steady operating conditions exist and thus the rate of heat loss from the wire equals the rate of heat generation in the wire as a result of resistance heating. **2** Thermal properties of water are constant. **3** Heat losses from the water in the tank are negligible.

**Properties** The specific heat of water at room temperature is  $c = 4.18 \text{ kJ/kg}\cdot^\circ\text{C}$  (Table A-9).

**Analysis** When steady operating conditions are reached, we have  $\dot{Q} = \dot{E}_{\text{generated}} = 800 \text{ W}$ . This is also equal to the rate of heat gain by water. Noting that this is the only mechanism of energy transfer, the time it takes to raise the water temperature from 20°C to 80°C is determined to be

$$Q_{\text{in}} = mc(T_2 - T_1)$$

$$\dot{Q}_{\text{in}} \Delta t = mc(T_2 - T_1)$$

$$\Delta t = \frac{mc(T_2 - T_1)}{\dot{Q}_{\text{in}}} = \frac{(75 \text{ kg})(4180 \text{ J/kg}\cdot^\circ\text{C})(80 - 20)^\circ\text{C}}{800 \text{ J/s}} = 23,510 \text{ s} = \mathbf{6.53 \text{ h}}$$

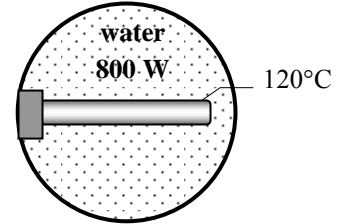

The surface area of the wire is

$$A_s = \pi DL = \pi(0.005 \text{ m})(0.4 \text{ m}) = 0.00628 \text{ m}^2$$

The Newton's law of cooling for convection heat transfer is expressed as  $\dot{Q} = hA_s(T_s - T_\infty)$ . Disregarding any heat transfer by radiation and thus assuming all the heat loss from the wire to occur by convection, the convection heat transfer coefficients at the beginning and at the end of the process are determined to be

$$h_1 = \frac{\dot{Q}}{A_s(T_s - T_{\infty 1})} = \frac{800 \text{ W}}{(0.00628 \text{ m}^2)(120 - 20)^\circ\text{C}} = \mathbf{1274 \text{ W/m}^2 \cdot ^\circ\text{C}}$$

$$h_2 = \frac{\dot{Q}}{A_s(T_s - T_{\infty 2})} = \frac{800 \text{ W}}{(0.00628 \text{ m}^2)(120 - 80)^\circ\text{C}} = \mathbf{3185 \text{ W/m}^2 \cdot ^\circ\text{C}}$$

**Discussion** Note that a larger heat transfer coefficient is needed to dissipate heat through a smaller temperature difference for a specified heat transfer rate.

**1-73** A hot water pipe at 80°C is losing heat to the surrounding air at 5°C by natural convection with a heat transfer coefficient of 25 W/m<sup>2</sup>·°C. The rate of heat loss from the pipe by convection is to be determined.

**Assumptions 1** Steady operating conditions exist. **2** Heat transfer by radiation is not considered. **3** The convection heat transfer coefficient is constant and uniform over the surface.

**Analysis** The heat transfer surface area is

$$A_s = \pi DL = \pi(0.05 \text{ m})(10 \text{ m}) = 1.571 \text{ m}^2$$

Under steady conditions, the rate of heat transfer by convection is

$$\dot{Q}_{\text{conv}} = hA_s \Delta T = (25 \text{ W/m}^2 \cdot ^\circ\text{C})(1.571 \text{ m}^2)(80 - 5)^\circ\text{C} = \mathbf{2945 \text{ W}}$$

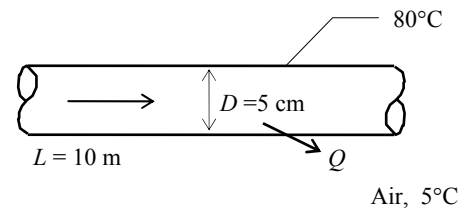

**1-74** A hollow spherical iron container is filled with iced water at  $0^{\circ}\text{C}$ . The rate of heat loss from the sphere and the rate at which ice melts in the container are to be determined.

**Assumptions** **1** Steady operating conditions exist since the surface temperatures of the wall remain constant at the specified values. **2** Heat transfer through the shell is one-dimensional. **3** Thermal properties of the iron shell are constant. **4** The inner surface of the shell is at the same temperature as the iced water,  $0^{\circ}\text{C}$ .

**Properties** The thermal conductivity of iron is  $k = 80.2 \text{ W/m}\cdot^{\circ}\text{C}$  (Table A-3). The heat of fusion of water is given to be  $333.7 \text{ kJ/kg}$ .

**Analysis** This spherical shell can be approximated as a plate of thickness  $0.4 \text{ cm}$  and area

$$A = \pi D^2 = \pi (0.2 \text{ m})^2 = 0.126 \text{ m}^2$$

Then the rate of heat transfer through the shell by conduction is

$$\dot{Q}_{\text{cond}} = kA \frac{\Delta T}{L} = (80.2 \text{ W/m}\cdot^{\circ}\text{C})(0.126 \text{ m}^2) \frac{(5 - 0)^{\circ}\text{C}}{0.002 \text{ m}} = 25,263 \text{ W} = \mathbf{25.3 \text{ kW}}$$

Considering that it takes  $333.7 \text{ kJ}$  of energy to melt  $1 \text{ kg}$  of ice at  $0^{\circ}\text{C}$ , the rate at which ice melts in the container can be determined from

$$\dot{m}_{\text{ice}} = \frac{\dot{Q}}{h_{if}} = \frac{25.263 \text{ kJ/s}}{333.7 \text{ kJ/kg}} = \mathbf{0.0757 \text{ kg/s}}$$

**Discussion** We should point out that this result is slightly in error for approximating a curved wall as a plain wall. The error in this case is very small because of the large diameter to thickness ratio. For better accuracy, we could use the inner surface area ( $D = 19.6 \text{ cm}$ ) or the mean surface area ( $D = 19.8 \text{ cm}$ ) in the calculations.

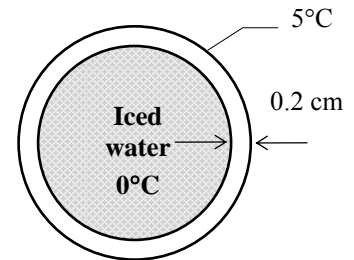





**1-75** Prob. 1-74 is reconsidered. The rate at which ice melts as a function of the container thickness is to be plotted.

**Analysis** The problem is solved using EES, and the solution is given below.

**"GIVEN"**

$$D=0.2 \text{ [m]}$$

$$L=0.2 \text{ [cm]}$$

$$T_1=0 \text{ [C]}$$

$$T_2=5 \text{ [C]}$$

**"PROPERTIES"**

$$h_{if}=333.7 \text{ [kJ/kg]}$$

$$k=k_{\text{(Iron, 25)}}$$

**"ANALYSIS"**

$$A=\pi \cdot D^2$$

$$Q_{\text{dot\_cond}}=k \cdot A \cdot (T_2 - T_1) / (L \cdot \text{Convert}(\text{cm}, \text{m}))$$

$$\dot{m}_{\text{ice}}=(Q_{\text{dot\_cond}} \cdot \text{Convert}(\text{W}, \text{kW})) / h_{if}$$

L [cm]	$\dot{m}_{\text{ice}}$ [kg/s]
0.1	0.1515
0.2	0.07574
0.3	0.0505
0.4	0.03787
0.5	0.0303
0.6	0.02525
0.7	0.02164
0.8	0.01894
0.9	0.01683
1	0.01515

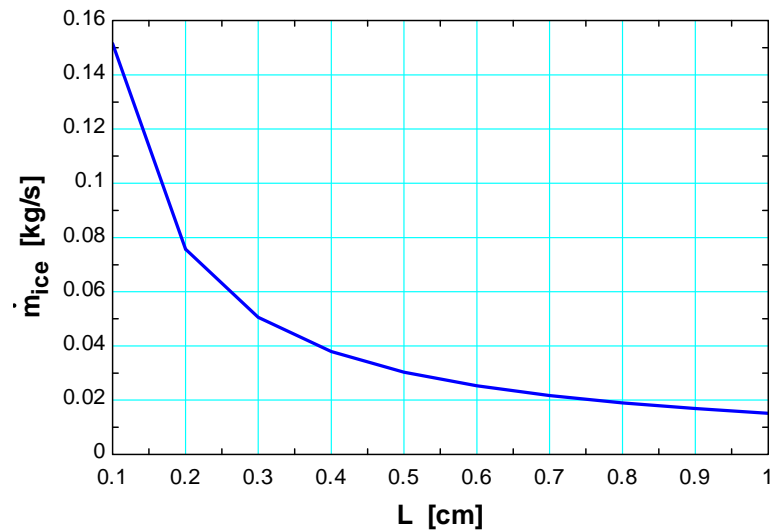

**1-76E** The inner and outer glasses of a double pane window with a 0.5-in air space are at specified temperatures. The rate of heat transfer through the window is to be determined

**Assumptions** **1** Steady operating conditions exist since the surface temperatures of the glass remain constant at the specified values. **2** Heat transfer through the window is one-dimensional. **3** Thermal properties of the air are constant.

**Properties** The thermal conductivity of air at the average temperature of  $(60+48)/2 = 54^\circ\text{F}$  is  $k = 0.01419 \text{ Btu/h}\cdot\text{ft}\cdot^\circ\text{F}$  (Table A-15E).

**Analysis** The area of the window and the rate of heat loss through it are

$$A = (4 \text{ ft}) \times (4 \text{ ft}) = 16 \text{ m}^2$$

$$\dot{Q} = kA \frac{T_1 - T_2}{L} = (0.01419 \text{ Btu/h}\cdot\text{ft}\cdot^\circ\text{F})(16 \text{ ft}^2) \frac{(60 - 48)^\circ\text{F}}{0.25/12 \text{ ft}} = \mathbf{131 \text{ Btu/h}}$$

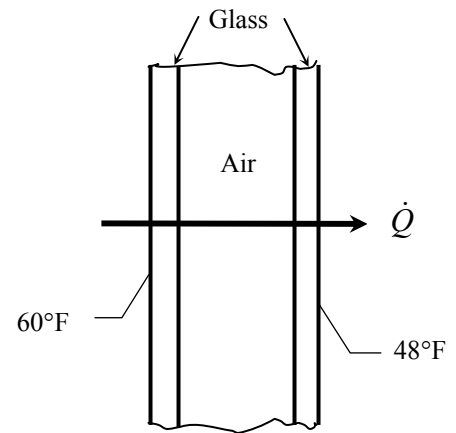

**1-77** A transistor mounted on a circuit board is cooled by air flowing over it. The transistor case temperature is not to exceed  $70^\circ\text{C}$  when the air temperature is  $55^\circ\text{C}$ . The amount of power this transistor can dissipate safely is to be determined.

**Assumptions** **1** Steady operating conditions exist. **2** Heat transfer by radiation is disregarded. **3** The convection heat transfer coefficient is constant and uniform over the surface. **4** Heat transfer from the base of the transistor is negligible.

**Analysis** Disregarding the base area, the total heat transfer area of the transistor is

$$\begin{aligned} A_s &= \pi DL + \pi D^2 / 4 \\ &= \pi(0.6 \text{ cm})(0.4 \text{ cm}) + \pi(0.6 \text{ cm})^2 / 4 = 1.037 \text{ cm}^2 \\ &= 1.037 \times 10^{-4} \text{ m}^2 \end{aligned}$$

Then the rate of heat transfer from the power transistor at specified conditions is

$$\dot{Q} = hA_s(T_s - T_\infty) = (30 \text{ W/m}^2 \cdot ^\circ\text{C})(1.037 \times 10^{-4} \text{ m}^2)(70 - 55)^\circ\text{C} = \mathbf{0.047 \text{ W}}$$

Therefore, the amount of power this transistor can dissipate safely is  $0.047 \text{ W}$ .

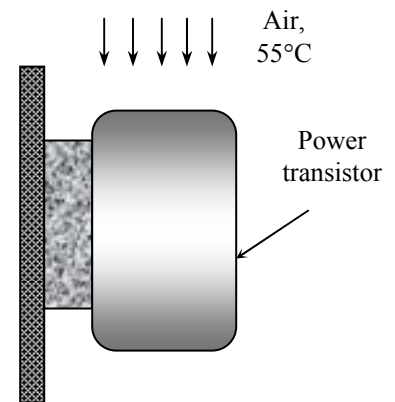



**1-78** Prob. 1-77 is reconsidered. The amount of power the transistor can dissipate safely as a function of the maximum case temperature is to be plotted.

**Analysis** The problem is solved using EES, and the solution is given below.

**"GIVEN"**

$$L=0.004 \text{ [m]}$$

$$D=0.006 \text{ [m]}$$

$$h=30 \text{ [W/m}^2\text{-C]}$$

$$T_{\text{infinity}}=55 \text{ [C]}$$

$$T_{\text{case\_max}}=70 \text{ [C]}$$

**"ANALYSIS"**

$$A=\pi \cdot D \cdot L + \pi \cdot D^2 / 4$$

$$Q_{\text{dot}}=h \cdot A \cdot (T_{\text{case\_max}} - T_{\text{infinity}})$$

$T_{\text{case, max}}$ [C]	Q [W]
60	0.01555
62.5	0.02333
65	0.0311
67.5	0.03888
70	0.04665
72.5	0.05443
75	0.0622
77.5	0.06998
80	0.07775
82.5	0.08553
85	0.09331
87.5	0.1011
90	0.1089

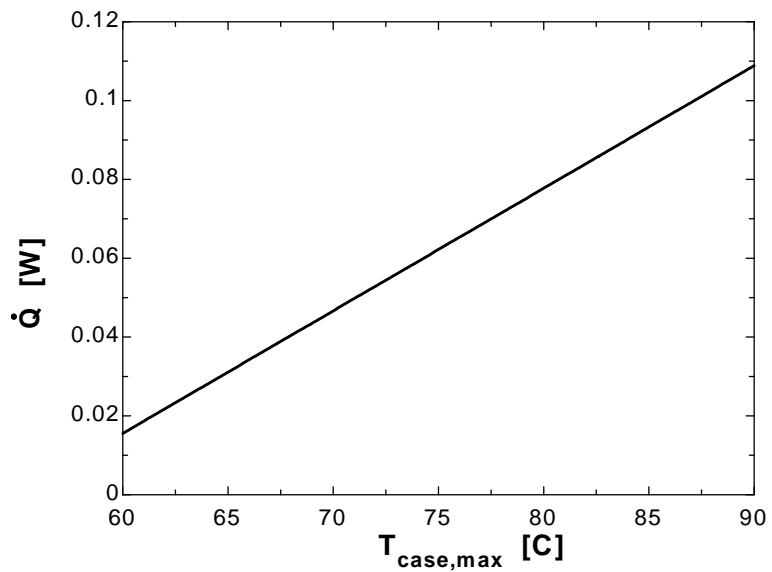

**1-79E** A 300-ft long section of a steam pipe passes through an open space at a specified temperature. The rate of heat loss from the steam pipe and the annual cost of this energy lost are to be determined.

**Assumptions** 1 Steady operating conditions exist. 2 Heat transfer by radiation is disregarded. 3 The convection heat transfer coefficient is constant and uniform over the surface.

**Analysis** (a) The rate of heat loss from the steam pipe is

$$A_s = \pi DL = \pi(4/12 \text{ ft})(300 \text{ ft}) = 314.2 \text{ ft}^2$$

$$\begin{aligned}\dot{Q}_{\text{pipe}} &= hA_s(T_s - T_{\text{air}}) = (6 \text{ Btu/h} \cdot \text{ft}^2 \cdot ^\circ\text{F})(314.2 \text{ ft}^2)(280 - 50)^\circ\text{F} \\ &= 433,540 \text{ Btu/h} \approx \mathbf{433,500 \text{ Btu/h}}\end{aligned}$$

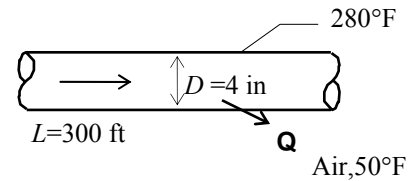

(b) The amount of heat loss per year is

$$Q = \dot{Q}\Delta t = (433,540 \text{ Btu/h})(365 \times 24 \text{ h/yr}) = 3.798 \times 10^9 \text{ Btu/yr}$$

The amount of gas consumption per year in the furnace that has an efficiency of 86% is

$$\text{Annual Energy Loss} = \frac{3.798 \times 10^9 \text{ Btu/yr}}{0.86} \left( \frac{1 \text{ therm}}{100,000 \text{ Btu}} \right) = 44,161 \text{ therms/yr}$$

Then the annual cost of the energy lost becomes

$$\begin{aligned}\text{Energy cost} &= (\text{Annual energy loss})(\text{Unit cost of energy}) \\ &= (44,161 \text{ therms/yr})(\$1.10/\text{therm}) = \mathbf{\$48,576/\text{yr}}\end{aligned}$$

**1-80** A 4-m diameter spherical tank filled with liquid nitrogen at 1 atm and  $-196^\circ\text{C}$  is exposed to convection with ambient air. The rate of evaporation of liquid nitrogen in the tank as a result of the heat transfer from the ambient air is to be determined.

**Assumptions** 1 Steady operating conditions exist. 2 Heat transfer by radiation is disregarded. 3 The convection heat transfer coefficient is constant and uniform over the surface. 4 The temperature of the thin-shelled spherical tank is nearly equal to the temperature of the nitrogen inside.

**Properties** The heat of vaporization and density of liquid nitrogen at 1 atm are given to be 198 kJ/kg and 810 kg/m<sup>3</sup>, respectively.

**Analysis** The rate of heat transfer to the nitrogen tank is

$$A_s = \pi D^2 = \pi(4 \text{ m})^2 = 50.27 \text{ m}^2$$

$$\begin{aligned}\dot{Q} &= hA_s(T_s - T_{\text{air}}) = (25 \text{ W/m}^2 \cdot ^\circ\text{C})(50.27 \text{ m}^2)[20 - (-196)]^\circ\text{C} \\ &= 271,430 \text{ W}\end{aligned}$$

Then the rate of evaporation of liquid nitrogen in the tank is determined to be

$$\dot{Q} = \dot{m}h_{fg} \longrightarrow \dot{m} = \frac{\dot{Q}}{h_{fg}} = \frac{271.430 \text{ kJ/s}}{198 \text{ kJ/kg}} = \mathbf{1.37 \text{ kg/s}}$$

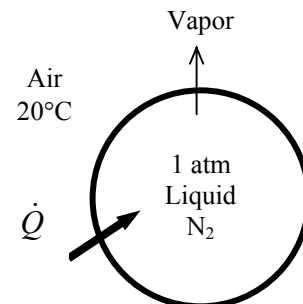

**1-81** A 4-m diameter spherical tank filled with liquid oxygen at 1 atm and  $-183^{\circ}\text{C}$  is exposed to convection with ambient air. The rate of evaporation of liquid oxygen in the tank as a result of the heat transfer from the ambient air is to be determined.

**Assumptions** **1** Steady operating conditions exist. **2** Heat transfer by radiation is disregarded. **3** The convection heat transfer coefficient is constant and uniform over the surface. **4** The temperature of the thin-shelled spherical tank is nearly equal to the temperature of the oxygen inside.

**Properties** The heat of vaporization and density of liquid oxygen at 1 atm are given to be  $213\text{ kJ/kg}$  and  $1140\text{ kg/m}^3$ , respectively.

**Analysis** The rate of heat transfer to the oxygen tank is

$$A_s = \pi D^2 = \pi (4\text{ m})^2 = 50.27\text{ m}^2$$

$$\begin{aligned}\dot{Q} &= hA_s(T_s - T_{\text{air}}) = (25\text{ W/m}^2 \cdot ^{\circ}\text{C})(50.27\text{ m}^2)[20 - (-183)]^{\circ}\text{C} \\ &= 255,120\text{ W}\end{aligned}$$

Then the rate of evaporation of liquid oxygen in the tank is determined to be

$$\dot{Q} = \dot{m}h_{fg} \longrightarrow \dot{m} = \frac{\dot{Q}}{h_{fg}} = \frac{255.120\text{ kJ/s}}{213\text{ kJ/kg}} = \mathbf{1.20\text{ kg/s}}$$

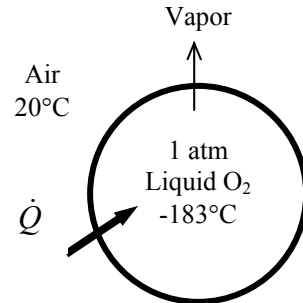



**1-82** Prob. 1-80 is reconsidered. The rate of evaporation of liquid nitrogen as a function of the ambient air temperature is to be plotted.

**Analysis** The problem is solved using EES, and the solution is given below.

**"GIVEN"**

D=4 [m]  
 T\_s=-196 [C]  
 T\_air=20 [C]  
 h=25 [W/m^2-C]

**"PROPERTIES"**

h\_fg=198 [kJ/kg]

**"ANALYSIS"**

A=pi\*D^2  
 Q\_dot=h\*A\*(T\_air-T\_s)  
 m\_dot\_evap=(Q\_dot\*Convert(J/s, kJ/s))/h\_fg

T <sub>air</sub> [C]	m <sub>evap</sub> [kg/s]
0	1.244
2.5	1.26
5	1.276
7.5	1.292
10	1.307
12.5	1.323
15	1.339
17.5	1.355
20	1.371
22.5	1.387
25	1.403
27.5	1.418
30	1.434
32.5	1.45
35	1.466
37.5	1.482
40	1.498

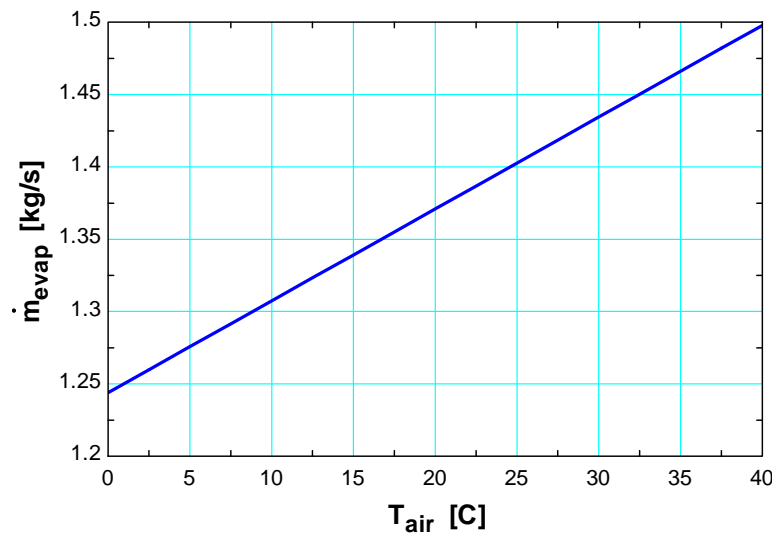

**1-83** A person with a specified surface temperature is subjected to radiation heat transfer in a room at specified wall temperatures. The rate of radiation heat loss from the person is to be determined.

**Assumptions** 1 Steady operating conditions exist. 2 Heat transfer by convection is disregarded. 3 The emissivity of the person is constant and uniform over the exposed surface.

**Properties** The average emissivity of the person is given to be 0.5.

**Analysis** Noting that the person is completely enclosed by the surrounding surfaces, the net rates of radiation heat transfer from the body to the surrounding walls, ceiling, and the floor in both cases are

(a)  $T_{\text{surr}} = 300 \text{ K}$

$$\begin{aligned}\dot{Q}_{\text{rad}} &= \varepsilon \sigma A_s (T_s^4 - T_{\text{surr}}^4) \\ &= (0.5)(5.67 \times 10^{-8} \text{ W/m}^2 \cdot \text{K}^4)(1.7 \text{ m}^2)[(32 + 273)^4 - (300 \text{ K})^4] \text{ K}^4 \\ &= \mathbf{26.7 \text{ W}}\end{aligned}$$

(b)  $T_{\text{surr}} = 280 \text{ K}$

$$\begin{aligned}\dot{Q}_{\text{rad}} &= \varepsilon \sigma A_s (T_s^4 - T_{\text{surr}}^4) \\ &= (0.5)(5.67 \times 10^{-8} \text{ W/m}^2 \cdot \text{K}^4)(1.7 \text{ m}^2)[(32 + 273)^4 - (280 \text{ K})^4] \text{ K}^4 \\ &= \mathbf{121 \text{ W}}\end{aligned}$$

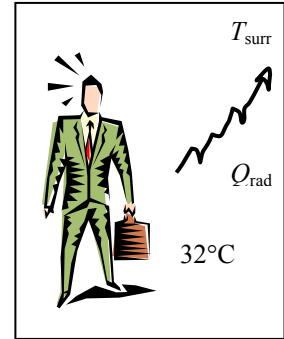

**Discussion** Note that the radiation heat transfer goes up by more than 4 times as the temperature of the surrounding surfaces drops from 300 K to 280 K.

**1-84** A circuit board houses 80 closely spaced logic chips on one side, each dissipating 0.06 W. All the heat generated in the chips is conducted across the circuit board. The temperature difference between the two sides of the circuit board is to be determined.

**Assumptions** 1 Steady operating conditions exist. 2 Thermal properties of the board are constant. 3 All the heat generated in the chips is conducted across the circuit board.

**Properties** The effective thermal conductivity of the board is given to be  $k = 16 \text{ W/m} \cdot ^\circ\text{C}$ .

**Analysis** The total rate of heat dissipated by the chips is

$$\dot{Q} = 80 \times (0.06 \text{ W}) = 4.8 \text{ W}$$

Then the temperature difference between the front and back surfaces of the board is

$$\begin{aligned}A &= (0.12 \text{ m})(0.18 \text{ m}) = 0.0216 \text{ m}^2 \\ \dot{Q} &= kA \frac{\Delta T}{L} \longrightarrow \Delta T = \frac{\dot{Q}L}{kA} = \frac{(4.8 \text{ W})(0.003 \text{ m})}{(16 \text{ W/m} \cdot ^\circ\text{C})(0.0216 \text{ m}^2)} = \mathbf{0.042^\circ\text{C}}\end{aligned}$$

**Discussion** Note that the circuit board is nearly isothermal.

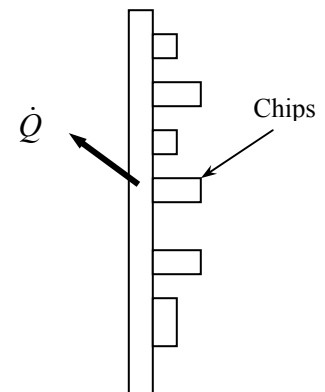

**1-85** A sealed electronic box dissipating a total of 120 W of power is placed in a vacuum chamber. If this box is to be cooled by radiation alone and the outer surface temperature of the box is not to exceed 55°C, the temperature the surrounding surfaces must be kept is to be determined.

**Assumptions** **1** Steady operating conditions exist. **2** Heat transfer by convection is disregarded. **3** The emissivity of the box is constant and uniform over the exposed surface. **4** Heat transfer from the bottom surface of the box to the stand is negligible.

**Properties** The emissivity of the outer surface of the box is given to be 0.95.

**Analysis** Disregarding the base area, the total heat transfer area of the electronic box is

$$A_s = (0.5 \text{ m})(0.5 \text{ m}) + 4 \times (0.2 \text{ m})(0.5 \text{ m}) = 0.65 \text{ m}^2$$

The radiation heat transfer from the box can be expressed as

$$\begin{aligned} \dot{Q}_{\text{rad}} &= \varepsilon \sigma A_s (T_s^4 - T_{\text{surr}}^4) \\ 120 \text{ W} &= (0.95)(5.67 \times 10^{-8} \text{ W/m}^2 \cdot \text{K}^4)(0.65 \text{ m}^2) \left[ (55 + 273 \text{ K})^4 - T_{\text{surr}}^4 \right] \end{aligned}$$

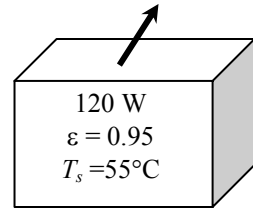

which gives  $T_{\text{surr}} = 300.4 \text{ K} = 27.4^\circ\text{C}$ . Therefore, the temperature of the surrounding surfaces must be less than 27.4°C.

**1-86E** Using the conversion factors between W and Btu/h, m and ft, and K and R, the Stefan-Boltzmann constant  $\sigma = 5.67 \times 10^{-8} \text{ W/m}^2 \cdot \text{K}^4$  is to be expressed in the English unit,  $\text{Btu/h} \cdot \text{ft}^2 \cdot \text{R}^4$ .

**Analysis** The conversion factors for W, m, and K are given in conversion tables to be

$$1 \text{ W} = 3.41214 \text{ Btu/h}$$

$$1 \text{ m} = 3.2808 \text{ ft}$$

$$1 \text{ K} = 1.8 \text{ R}$$

Substituting gives the Stefan-Boltzmann constant in the desired units,

$$\sigma = 5.67 \text{ W/m}^2 \cdot \text{K}^4 = 5.67 \times \frac{3.41214 \text{ Btu/h}}{(3.2808 \text{ ft})^2 (1.8 \text{ R})^4} = 0.171 \text{ Btu/h} \cdot \text{ft}^2 \cdot \text{R}^4$$



**1-87E** Using the conversion factors between W and Btu/h, m and ft, and °C and °F, the convection coefficient in SI units is to be expressed in Btu/h·ft<sup>2</sup>·°F.

**Analysis** The conversion factors for W and m are straightforward, and are given in conversion tables to be

$$1 \text{ W} = 3.41214 \text{ Btu/h}$$

$$1 \text{ m} = 3.2808 \text{ ft}$$

The proper conversion factor between °C into °F in this case is

$$1^\circ\text{C} = 1.8^\circ\text{F}$$

since the °C in the unit W/m<sup>2</sup>·°C represents *per °C change in temperature*, and 1°C change in temperature corresponds to a change of 1.8°F. Substituting, we get

$$1 \text{ W/m}^2 \cdot ^\circ\text{C} = \frac{3.41214 \text{ Btu/h}}{(3.2808 \text{ ft})^2 (1.8^\circ\text{F})} = 0.1761 \text{ Btu/h} \cdot \text{ft}^2 \cdot ^\circ\text{F}$$

which is the desired conversion factor. Therefore, the given convection heat transfer coefficient in English units is

$$h = 22 \text{ W/m}^2 \cdot ^\circ\text{C} = 22 \times 0.1761 \text{ Btu/h} \cdot \text{ft}^2 \cdot ^\circ\text{F} = \mathbf{3.87 \text{ Btu/h} \cdot \text{ft}^2 \cdot ^\circ\text{F}}$$

**1-88** An aircraft flying under icing conditions is considered. The temperature of the wings to prevent ice from forming on them is to be determined.

**Assumptions** **1** Steady operating conditions exist. **2** Heat transfer coefficient is constant.

**Properties** The heat of fusion and the density of ice are given to be 333.7 kJ/kg and 920 kg/m<sup>3</sup>, respectively.

**Analysis** The temperature of the wings to prevent ice from forming on them is determined to be

$$T_{\text{wing}} = T_{\text{ice}} + \frac{\rho V h_{if}}{h} = 0^\circ\text{C} + \frac{(920 \text{ kg/m}^3)(0.001/60 \text{ m/s})(333,700 \text{ J/kg})}{150 \text{ W/m}^2 \cdot ^\circ\text{C}} = \mathbf{34.1^\circ\text{C}}$$

**1-89** The convection heat transfer coefficient for heat transfer from an electrically heated wire to air is to be determined by measuring temperatures when steady operating conditions are reached and the electric power consumed.

**Assumptions 1** Steady operating conditions exist since the temperature readings do not change with time. **2** Radiation heat transfer is negligible.

**Analysis** In steady operation, the rate of heat loss from the wire equals the rate of heat generation in the wire as a result of resistance heating. That is,

$$\dot{Q} = \dot{E}_{\text{generated}} = \mathbf{VI} = (110 \text{ V})(3 \text{ A}) = 330 \text{ W}$$

The surface area of the wire is

$$A_s = \pi DL = \pi(0.002 \text{ m})(2.1 \text{ m}) = 0.01319 \text{ m}^2$$

The Newton's law of cooling for convection heat transfer is expressed as

$$\dot{Q} = hA_s(T_s - T_\infty)$$

Disregarding any heat transfer by radiation, the convection heat transfer coefficient is determined to be

$$h = \frac{\dot{Q}}{A_s(T_s - T_\infty)} = \frac{330 \text{ W}}{(0.01319 \text{ m}^2)(180 - 20)^\circ\text{C}} = \mathbf{156 \text{ W/m}^2 \cdot ^\circ\text{C}}$$

**Discussion** If the temperature of the surrounding surfaces is equal to the air temperature in the room, the value obtained above actually represents the combined convection and radiation heat transfer coefficient.

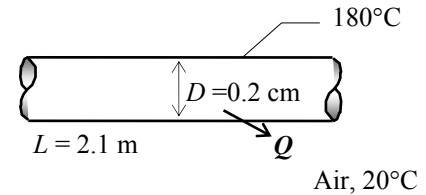



**1-90** Prob. 1-89 is reconsidered. The convection heat transfer coefficient as a function of the wire surface temperature is to be plotted.

**Analysis** The problem is solved using EES, and the solution is given below.

**"GIVEN"**

L=2.1 [m]  
 D=0.002 [m]  
 T\_infinity=20 [C]  
 T\_s=180 [C]  
 V=110 [Volt]  
 I=3 [Ampere]

**"ANALYSIS"**

Q\_dot=V\*I  
 A=pi\*D\*L  
 Q\_dot=h\*A\*(T\_s-T\_infinity)

T <sub>s</sub> [C]	h [W/m <sup>2</sup> .C]
100	312.6
120	250.1
140	208.4
160	178.6
180	156.3
200	138.9
220	125.1
240	113.7
260	104.2
280	96.19
300	89.32

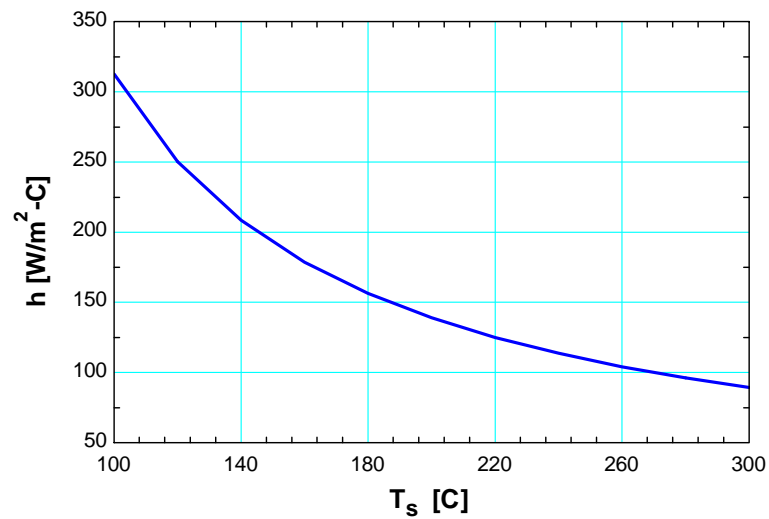

## Simultaneous Heat Transfer Mechanisms

**1-91C** All three modes of heat transfer can not occur simultaneously in a medium. A medium may involve two of them simultaneously.

**1-92C** (a) Conduction and convection: No. (b) Conduction and radiation: Yes. Example: A hot surface on the ceiling. (c) Convection and radiation: Yes. Example: Heat transfer from the human body.

**1-93C** The human body loses heat by convection, radiation, and evaporation in both summer and winter. In summer, we can keep cool by dressing lightly, staying in cooler environments, turning a fan on, avoiding humid places and direct exposure to the sun. In winter, we can keep warm by dressing heavily, staying in a warmer environment, and avoiding drafts.

**1-94C** The fan increases the air motion around the body and thus the convection heat transfer coefficient, which increases the rate of heat transfer from the body by convection and evaporation. In rooms with high ceilings, ceiling fans are used in winter to force the warm air at the top downward to increase the air temperature at the body level. This is usually done by forcing the air up which hits the ceiling and moves downward in a gently manner to avoid drafts.

**1-95** The total rate of heat transfer from a person by both convection and radiation to the surrounding air and surfaces at specified temperatures is to be determined.

**Assumptions** **1** Steady operating conditions exist. **2** The person is completely surrounded by the interior surfaces of the room. **3** The surrounding surfaces are at the same temperature as the air in the room. **4** Heat conduction to the floor through the feet is negligible. **5** The convection coefficient is constant and uniform over the entire surface of the person.

**Properties** The emissivity of a person is given to be  $\varepsilon = 0.9$ .

**Analysis** The person is completely enclosed by the surrounding surfaces, and he or she will lose heat to the surrounding air by convection and to the surrounding surfaces by radiation. The total rate of heat loss from the person is determined from

$$\dot{Q}_{\text{rad}} = \varepsilon \sigma A_s (T_s^4 - T_{\text{surr}}^4) = (0.90)(5.67 \times 10^{-8} \text{ W/m}^2 \cdot \text{K}^4)(1.7 \text{ m}^2)[(32 + 273)^4 - (18 + 273)^4] \text{ K}^4 = 128.6 \text{ W}$$

$$\dot{Q}_{\text{conv}} = h A_s \Delta T = (5 \text{ W/m}^2 \cdot \text{K})(1.7 \text{ m}^2)(32 - 18)^\circ\text{C} = 119 \text{ W}$$

and

$$\dot{Q}_{\text{total}} = \dot{Q}_{\text{conv}} + \dot{Q}_{\text{rad}} = 128.6 + 119 = \mathbf{247.6 \text{ W}}$$

**Discussion** Note that heat transfer from the person by evaporation, which is of comparable magnitude, is not considered in this problem.

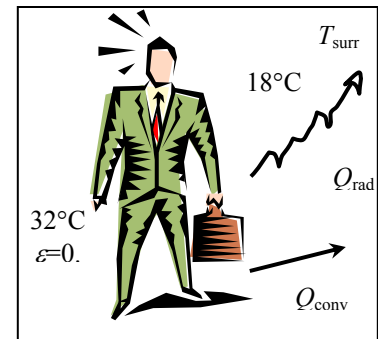

**1-96** Two large plates at specified temperatures are held parallel to each other. The rate of heat transfer between the plates is to be determined for the cases of still air, evacuation, regular insulation, and super insulation between the plates.

**Assumptions** **1** Steady operating conditions exist since the plate temperatures remain constant. **2** Heat transfer is one-dimensional since the plates are large. **3** The surfaces are black and thus  $\varepsilon = 1$ . **4** There are no convection currents in the air space between the plates.

**Properties** The thermal conductivities are  $k = 0.00015 \text{ W/m}\cdot^\circ\text{C}$  for super insulation,  $k = 0.01979 \text{ W/m}\cdot^\circ\text{C}$  at  $-50^\circ\text{C}$  (Table A-15) for air, and  $k = 0.036 \text{ W/m}\cdot^\circ\text{C}$  for fiberglass insulation (Table A-6).

**Analysis** (a) Disregarding any natural convection currents, the rates of conduction and radiation heat transfer

$$\dot{Q}_{\text{cond}} = kA \frac{T_1 - T_2}{L} = (0.01979 \text{ W/m}^2 \cdot ^\circ\text{C})(1 \text{ m}^2) \frac{(290 - 150) \text{ K}}{0.02 \text{ m}} = 139 \text{ W}$$

$$\begin{aligned} \dot{Q}_{\text{rad}} &= \varepsilon \sigma A_s (T_1^4 - T_2^4) \\ &= 1(5.67 \times 10^{-8} \text{ W/m}^2 \cdot \text{K}^4)(1 \text{ m}^2) [(290 \text{ K})^4 - (150 \text{ K})^4] = 372 \text{ W} \end{aligned}$$

$$\dot{Q}_{\text{total}} = \dot{Q}_{\text{cond}} + \dot{Q}_{\text{rad}} = 139 + 372 = \mathbf{511 \text{ W}}$$

(b) When the air space between the plates is evacuated, there will be radiation heat transfer only. Therefore,

$$\dot{Q}_{\text{total}} = \dot{Q}_{\text{rad}} = \mathbf{372 \text{ W}}$$

(c) In this case there will be conduction heat transfer through the fiberglass insulation only,

$$\dot{Q}_{\text{total}} = \dot{Q}_{\text{cond}} = kA \frac{T_1 - T_2}{L} = (0.036 \text{ W/m}\cdot^\circ\text{C})(1 \text{ m}^2) \frac{(290 - 150) \text{ K}}{0.02 \text{ m}} = \mathbf{252 \text{ W}}$$

(d) In the case of superinsulation, the rate of heat transfer will be

$$\dot{Q}_{\text{total}} = \dot{Q}_{\text{cond}} = kA \frac{T_1 - T_2}{L} = (0.00015 \text{ W/m}\cdot^\circ\text{C})(1 \text{ m}^2) \frac{(290 - 150) \text{ K}}{0.02 \text{ m}} = \mathbf{1.05 \text{ W}}$$

**Discussion** Note that superinsulators are very effective in reducing heat transfer between to surfaces.

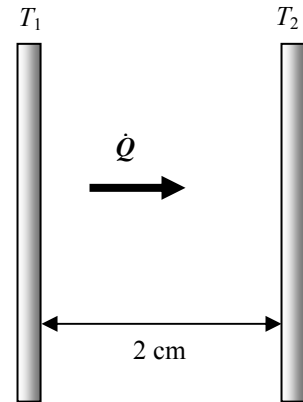

**1-97** The outer surface of a wall is exposed to solar radiation. The effective thermal conductivity of the wall is to be determined.

**Assumptions 1** Steady operating conditions exist. **2** The heat transfer coefficient is constant and uniform over the surface.

**Properties** Both the solar absorptivity and emissivity of the wall surface are given to be 0.8.

**Analysis** The heat transfer through the wall by conduction is equal to net heat transfer to the outer wall surface:

$$\begin{aligned}\dot{q}_{\text{cond}} &= \dot{q}_{\text{conv}} + \dot{q}_{\text{rad}} + \dot{q}_{\text{solar}} \\ k \frac{T_2 - T_1}{L} &= h(T_o - T_2) + \varepsilon\sigma(T_{\text{surr}}^4 - T_2^4) + \alpha_s q_{\text{solar}} \\ k \frac{(44 - 27)^\circ\text{C}}{0.25 \text{ m}} &= (8 \text{ W/m}^2 \cdot ^\circ\text{C})(40 - 44)^\circ\text{C} + (0.8)(5.67 \times 10^{-8} \text{ W/m}^2 \cdot \text{K}^4) \left[ (40 + 273 \text{ K})^4 - (44 + 273 \text{ K})^4 \right] \\ &\quad + (0.8)(150 \text{ W/m}^2)\end{aligned}$$

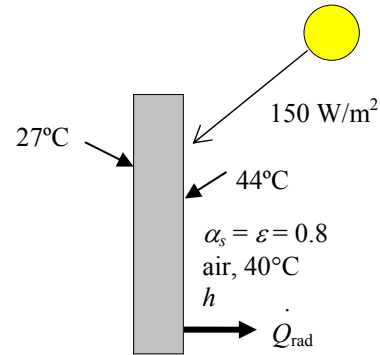

Solving for  $k$  gives

$$k = \mathbf{0.961 \text{ W/m} \cdot ^\circ\text{C}}$$

**1-98E** A spherical ball whose surface is maintained at a temperature of  $170^\circ\text{F}$  is suspended in the middle of a room at  $70^\circ\text{F}$ . The total rate of heat transfer from the ball is to be determined.

**Assumptions 1** Steady operating conditions exist since the ball surface and the surrounding air and surfaces remain at constant temperatures. **2** The thermal properties of the ball and the convection heat transfer coefficient are constant and uniform.

**Properties** The emissivity of the ball surface is given to be  $\varepsilon = 0.8$ .

**Analysis** The heat transfer surface area is

$$A_s = \pi D^2 = \pi(2/12 \text{ ft})^2 = 0.08727 \text{ ft}^2$$

Under steady conditions, the rates of convection and radiation heat transfer are

$$\begin{aligned}\dot{Q}_{\text{conv}} &= hA_s \Delta T = (15 \text{ Btu/h} \cdot \text{ft}^2 \cdot ^\circ\text{F})(0.08727 \text{ ft}^2)(170 - 70)^\circ\text{F} = 130.9 \text{ Btu/h} \\ \dot{Q}_{\text{rad}} &= \varepsilon\sigma A_s (T_s^4 - T_o^4) \\ &= 0.8(0.08727 \text{ ft}^2)(0.1714 \times 10^{-8} \text{ Btu/h} \cdot \text{ft}^2 \cdot \text{R}^4) \left[ (170 + 460 \text{ R})^4 - (70 + 460 \text{ R})^4 \right] \\ &= 9.4 \text{ Btu/h}\end{aligned}$$

Therefore,

$$\dot{Q}_{\text{total}} = \dot{Q}_{\text{conv}} + \dot{Q}_{\text{rad}} = 130.9 + 9.4 = \mathbf{140.3 \text{ Btu/h}}$$

**Discussion** Note that heat loss by convection is several times that of heat loss by radiation. The radiation heat loss can further be reduced by coating the ball with a low-emissivity material.

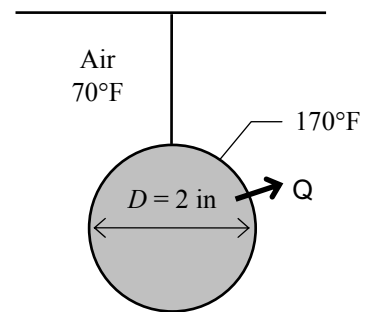



**1-99** An 800-W iron is left on the iron board with its base exposed to the air at 20°C. The temperature of the base of the iron is to be determined in steady operation.

**Assumptions** 1 Steady operating conditions exist. 2 The thermal properties of the iron base and the convection heat transfer coefficient are constant and uniform. 3 The temperature of the surrounding surfaces is the same as the temperature of the surrounding air.

**Properties** The emissivity of the base surface is given to be  $\varepsilon = 0.6$ .

**Analysis** At steady conditions, the 800 W energy supplied to the iron will be dissipated to the surroundings by convection and radiation heat transfer. Therefore,

$$\dot{Q}_{\text{total}} = \dot{Q}_{\text{conv}} + \dot{Q}_{\text{rad}} = 800 \text{ W}$$

where

$$\dot{Q}_{\text{conv}} = hA_s\Delta T = (35 \text{ W/m}^2 \cdot \text{K})(0.02 \text{ m}^2)(T_s - 293 \text{ K}) = 0.7(T_s - 293 \text{ K})$$

and

$$\begin{aligned} \dot{Q}_{\text{rad}} &= \varepsilon\sigma A_s(T_s^4 - T_o^4) = 0.6(0.02 \text{ m}^2)(5.67 \times 10^{-8} \text{ W/m}^2 \cdot \text{K}^4)[T_s^4 - (293 \text{ K})^4] \\ &= 0.06804 \times 10^{-8} [T_s^4 - (293 \text{ K})^4] \end{aligned}$$

Substituting,

$$800 \text{ W} = 0.7(T_s - 293 \text{ K}) + 0.06804 \times 10^{-8} [T_s^4 - (293 \text{ K})^4]$$

Solving by trial and error gives

$$T_s = 874 \text{ K} = \mathbf{601^\circ\text{C}}$$

**Discussion** We note that the iron will dissipate all the energy it receives by convection and radiation when its surface temperature reaches 874 K.

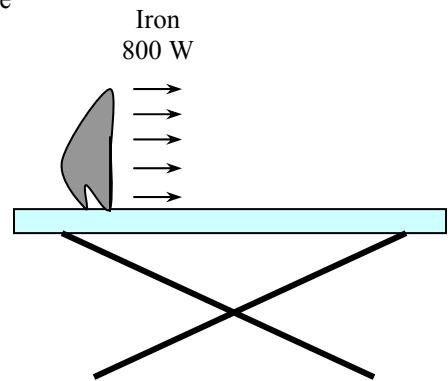

**1-100** A spherical tank located outdoors is used to store iced water at  $0^\circ\text{C}$ . The rate of heat transfer to the iced water in the tank and the amount of ice at  $0^\circ\text{C}$  that melts during a 24-h period are to be determined.

**Assumptions** **1** Steady operating conditions exist since the surface temperatures of the wall remain constant at the specified values. **2** Thermal properties of the tank and the convection heat transfer coefficient is constant and uniform. **3** The average surrounding surface temperature for radiation exchange is  $15^\circ\text{C}$ . **4** The thermal resistance of the tank is negligible, and the entire steel tank is at  $0^\circ\text{C}$ .

**Properties** The heat of fusion of water at atmospheric pressure is  $h_{if} = 333.7 \text{ kJ/kg}$ . The emissivity of the outer surface of the tank is 0.75.

**Analysis** (a) The outer surface area of the spherical tank is

$$A_s = \pi D^2 = \pi(3.02 \text{ m})^2 = 28.65 \text{ m}^2$$

Then the rates of heat transfer to the tank by convection and radiation become

$$\dot{Q}_{\text{conv}} = hA_s(T_\infty - T_s) = (30 \text{ W/m}^2 \cdot ^\circ\text{C})(28.65 \text{ m}^2)(25 - 0)^\circ\text{C} = 21,488 \text{ W}$$

$$\dot{Q}_{\text{rad}} = \varepsilon A_s \sigma (T_{\text{surr}}^4 - T_s^4) = (0.75)(28.65 \text{ m}^2)(5.67 \times 10^{-8} \text{ W/m}^2 \cdot \text{K}^4)[(288 \text{ K})^4 - (273 \text{ K})^4] = 1614 \text{ W}$$

$$\dot{Q}_{\text{total}} = \dot{Q}_{\text{conv}} + \dot{Q}_{\text{rad}} = 21,488 + 1614 = 23,102 \text{ W} = \mathbf{23.1 \text{ kW}}$$

(b) The amount of heat transfer during a 24-hour period is

$$Q = \dot{Q}\Delta t = (23.102 \text{ kJ/s})(24 \times 3600 \text{ s}) = 1,996,000 \text{ kJ}$$

Then the amount of ice that melts during this period becomes

$$Q = mh_{if} \longrightarrow m = \frac{Q}{h_{if}} = \frac{1,996,000 \text{ kJ}}{333.7 \text{ kJ/kg}} = \mathbf{5980 \text{ kg}}$$

**Discussion** The amount of ice that melts can be reduced to a small fraction by insulating the tank.

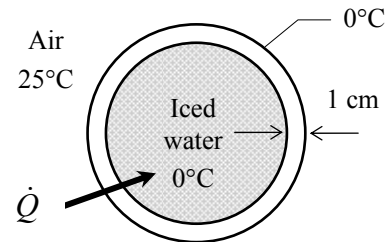





**1-101** The roof of a house with a gas furnace consists of a 22-cm thick concrete that is losing heat to the outdoors by radiation and convection. The rate of heat transfer through the roof and the money lost through the roof that night during a 14 hour period are to be determined.

**Assumptions** 1 Steady operating conditions exist. 2 The emissivity and thermal conductivity of the roof are constant.

**Properties** The thermal conductivity of the concrete is given to be  $k = 2 \text{ W/m}\cdot\text{C}$ . The emissivity of the outer surface of the roof is given to be 0.9.

**Analysis** In steady operation, heat transfer from the outer surface of the roof to the surroundings by convection and radiation must be equal to the heat transfer through the roof by conduction. That is,

$$\dot{Q} = \dot{Q}_{\text{roof, cond}} = \dot{Q}_{\text{roof to surroundings, conv+rad}}$$

The inner surface temperature of the roof is given to be  $T_{s,\text{in}} = 15^\circ\text{C}$ . Letting  $T_{s,\text{out}}$  denote the outer surface temperatures of the roof, the energy balance above can be expressed as

$$\begin{aligned} \dot{Q} &= kA \frac{T_{s,\text{in}} - T_{s,\text{out}}}{L} = h_o A (T_{s,\text{out}} - T_{\text{surr}}) + \varepsilon A \sigma (T_{s,\text{out}}^4 - T_{\text{surr}}^4) \\ \dot{Q} &= (2 \text{ W/m}\cdot\text{C})(300 \text{ m}^2) \frac{15^\circ\text{C} - T_{s,\text{out}}}{0.22 \text{ m}} \\ &= (15 \text{ W/m}^2\cdot\text{C})(300 \text{ m}^2)(T_{s,\text{out}} - 10)^\circ\text{C} \\ &\quad + (0.9)(300 \text{ m}^2)(5.67 \times 10^{-8} \text{ W/m}^2\cdot\text{K}^4) [(T_{s,\text{out}} + 273 \text{ K})^4 - (255 \text{ K})^4] \end{aligned}$$

Solving the equations above using an equation solver (or by trial and error) gives

$$\dot{Q} = \mathbf{19,830 \text{ W}} \quad \text{and} \quad T_{s,\text{out}} = \mathbf{7.8^\circ\text{C}}$$

Then the amount of natural gas consumption during a 16-hour period is

$$E_{\text{gas}} = \frac{Q_{\text{total}}}{0.85} = \frac{\dot{Q}\Delta t}{0.85} = \frac{(19.83 \text{ kJ/s})(14 \times 3600 \text{ s})}{0.85} \left( \frac{1 \text{ therm}}{105,500 \text{ kJ}} \right) = 11.15 \text{ therms}$$

Finally, the money lost through the roof during that period is

$$\text{Money lost} = (11.15 \text{ therms})(\$1.20 / \text{therm}) = \mathbf{\$13.4}$$

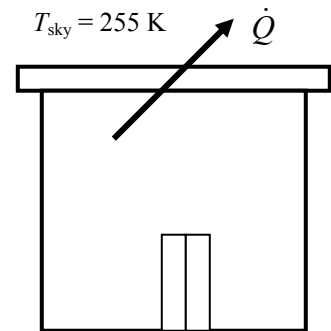

**1-102E** A flat plate solar collector is placed horizontally on the roof of a house. The rate of heat loss from the collector by convection and radiation during a calm day are to be determined.

**Assumptions** **1** Steady operating conditions exist. **2** The emissivity and convection heat transfer coefficient are constant and uniform. **3** The exposed surface, ambient, and sky temperatures remain constant.

**Properties** The emissivity of the outer surface of the collector is given to be 0.9.

**Analysis** The exposed surface area of the collector is

$$A_s = (5 \text{ ft})(15 \text{ ft}) = 75 \text{ ft}^2$$

Noting that the exposed surface temperature of the collector is  $100^\circ\text{F}$ , the total rate of heat loss from the collector to the environment by convection and radiation becomes

$$\dot{Q}_{\text{conv}} = hA_s(T_\infty - T_s) = (2.5 \text{ Btu/h}\cdot\text{ft}^2 \cdot ^\circ\text{F})(75 \text{ ft}^2)(100 - 70)^\circ\text{F} = 5625 \text{ Btu/h}$$

$$\begin{aligned} \dot{Q}_{\text{rad}} &= \varepsilon A_s \sigma (T_{\text{surr}}^4 - T_s^4) = (0.9)(75 \text{ ft}^2)(0.1714 \times 10^{-8} \text{ Btu/h}\cdot\text{ft}^2 \cdot \text{R}^4)[(100 + 460 \text{ R})^4 - (50 + 460 \text{ R})^4] \\ &= 3551 \text{ Btu/h} \end{aligned}$$

and

$$\dot{Q}_{\text{total}} = \dot{Q}_{\text{conv}} + \dot{Q}_{\text{rad}} = 5625 + 3551 = \mathbf{9176 \text{ Btu/h}}$$

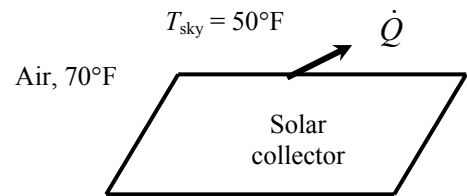

**1-103** Temperature of the stainless steel sheet going through an annealing process inside an electrically heated oven is to be determined.

**Assumptions** 1 Steady operating conditions exist. 2 Temperature of the stainless steel sheet is uniform. 3 Radiation heat transfer between stainless steel sheet and surrounding oven surfaces is between a small object and a large enclosure.

**Properties** The emissivity of the stainless steel sheet is given to be 0.40.

**Analysis** The amount of heat transfer by radiation between the sheet and the surrounding oven surfaces is balanced by the convection heat transfer between the sheet and the ambient air:

$$\dot{q}_{\text{rad}} - \dot{q}_{\text{conv}} = 0$$

$$\varepsilon\sigma(T_{\text{surr}}^4 - T_s^4) - h(T_s - T_{\infty}) = 0$$

$$(0.40)(5.67 \times 10^{-8} \text{ W/m}^2 \cdot \text{K}^4)[(750 + 273)^4 - T_s^4] \text{K}^4 - (10 \text{ W/m}^2 \cdot \text{K})[T_s - (600 + 273)] \text{K} = 0$$

Solving the above equation by EES software (Copy the following line and paste on a blank EES screen to verify solution):

$$0.40 * 5.67e-8 * ((750+273)^4 - T_s^4) - 10 * (T_s - (600+273)) = 0$$

The temperature of the stainless steel sheet is

$$T_s = 1009 \text{ K} = \mathbf{736^\circ\text{C}}$$

**Discussion** Note that the energy balance equation involving radiation heat transfer used for solving the stainless steel sheet temperature must be used with absolute temperature.

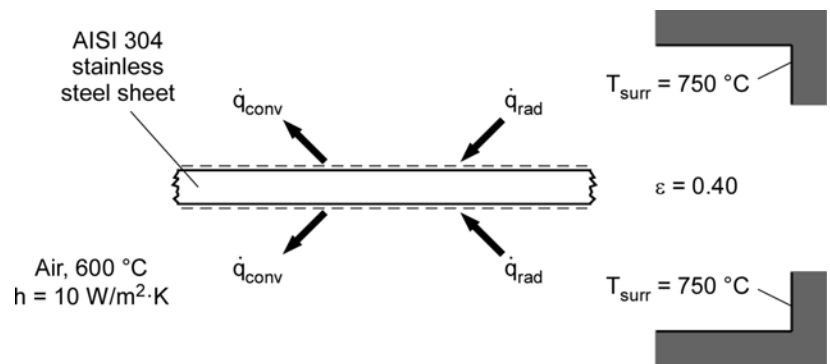

**1-104** The upper surface temperature of a silicon wafer undergoing heat treatment in a vacuum chamber by infrared heater is to be determined.

**Assumptions** 1 Steady operating conditions exist. 2 Radiation heat transfer between upper wafer surface and surroundings is between a small object and a large enclosure. 3 One-dimensional conduction in wafer. 4 The silicon wafer has constant properties. 5 No hot spot exists on the wafer.

**Properties** The thermal conductivity of silicon at 1000 K is  $31.2 \text{ W/m} \cdot \text{K}$  (Table A-3).

**Analysis** The heat transfer through the thickness of the wafer by conduction is equal to net heat transfer at the upper wafer surface:

$$\dot{q}_{\text{cond}} = \dot{q}_{\text{abs}} - \dot{q}_{\text{rad}}$$

$$k \frac{T_{s,u} - T_{s,l}}{L} = \alpha \dot{q}_{\text{IR}} - \varepsilon \sigma (T_{s,u}^4 - T_{\text{surr}}^4)$$

$$(31.2 \text{ W/m} \cdot \text{K}) \frac{(T_{s,u} - 1000) \text{ K}}{(725 \times 10^{-6} \text{ m})} = (0.70)(200000 \text{ W/m}^2) - (0.70)(5.67 \times 10^{-8} \text{ W/m}^2 \cdot \text{K}^4)(T_{s,u}^4 - 310^4) \text{ K}^4$$

Copy the following line and paste on a blank EES screen to solve the above equation:

$$31.2*(T_{\text{su}}-1000)/725\text{e-}6=0.70*200000-0.70*5.67\text{e-}8*(T_{\text{su}}^4-310^4)$$

Solving by EES software, the upper surface temperature of silicon wafer is

$$T_{s,u} = \mathbf{1002 \text{ K}}$$

**Discussion** Excessive temperature difference across the wafer thickness will cause warping in the silicon wafer.

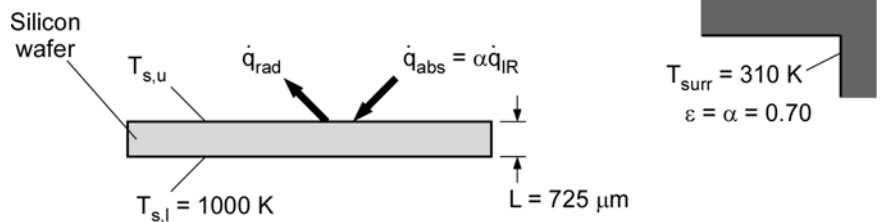

## Problem Solving Techniques and EES

**1-105C** Despite the convenience and capability the engineering software packages offer, they are still just tools, and they will not replace the traditional engineering courses. They will simply cause a shift in emphasis in the course material from mathematics to physics. They are of great value in engineering practice, however, as engineers today rely on software packages for solving large and complex problems in a short time, and perform optimization studies efficiently.

**1-106**  We are to determine a positive real root of the following equation using EES:  $3.5x^3 - 10x^{0.5} - 3x = -4$ .

*Analysis* Using EES software, copy the following lines and paste on a blank EES screen to verify the solution:

$$3.5*x^3-10*x^{0.5}-3*x = -4$$

*Answer:*  $x = 1.554$

*Discussion* To obtain the solution in EES, click on the icon that looks like a calculator, or Calculate-Solve.

**1-107**  We are to solve a system of 2 equations and 2 unknowns using EES.

*Analysis* Using EES software, copy the following lines and paste on a blank EES screen to verify the solution:

$$x^3-y^2=10.5$$

$$3*x*y+y=4.6$$

*Answers:*  $x = 2.215$ ,  $y = 0.6018$

*Discussion* To obtain the solution in EES, click on the icon that looks like a calculator, or Calculate-Solve.

**1-108**  We are to solve a system of 3 equations with 3 unknowns using EES.

*Analysis* Using EES software, copy the following lines and paste on a blank EES screen to verify the solution:

$$2*x-y+z=5$$

$$3*x^2+2*y=z+2$$

$$x*y+2*z=8$$

*Answers:*  $x = 1.141$ ,  $y = 0.8159$ ,  $z = 3.535$ .

*Discussion* To obtain the solution in EES, click on the icon that looks like a calculator, or Calculate-Solve.

**1-109**  We are to solve a system of 3 equations with 3 unknowns using EES.

**Analysis** Using EES software, copy the following lines and paste on a blank EES screen to verify the solution:

$$x^2*y-z=1.5$$

$$x-3*y^{0.5}+x*z=-2$$

$$x+y-z=4.2$$

**Answers:**  $x = 0.9149$ ,  $y = 10.95$ ,  $z = 7.665$

**Discussion** To obtain the solution in EES, click on the icon that looks like a calculator, or Calculate-Solve.

**1-110**  The squares of the number from 1 to 100 in increments of 10 are to be evaluated using the parametric table and plot features of EES.

**Analysis** The problem is solved using EES, and the solution is given below.

$$x=1$$

$$y=x^2$$

x	y
1	1
10	100
20	400
30	900
40	1600
50	2500
60	3600
70	4900
80	6400
90	8100
100	10000

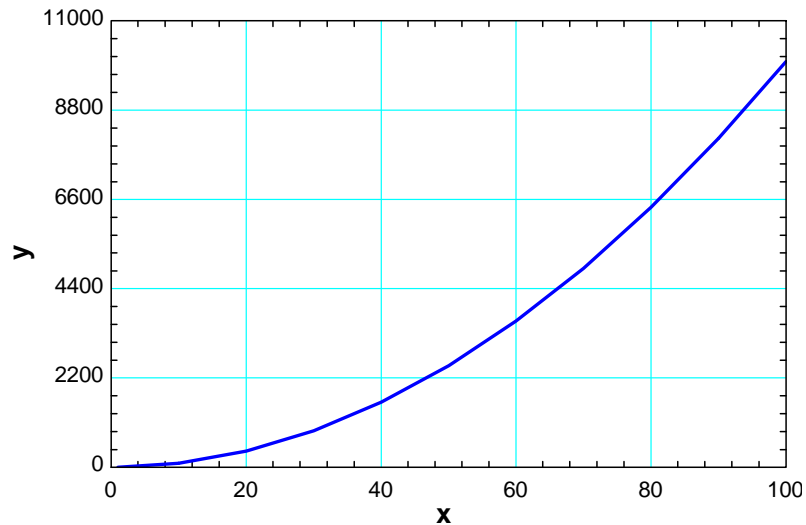

**Special Topic: Thermal Comfort**

**1-111C** The metabolism refers to the burning of foods such as carbohydrates, fat, and protein in order to perform the necessary bodily functions. The metabolic rate for an average man ranges from 108 W while reading, writing, typing, or listening to a lecture in a classroom in a seated position to 1250 W at age 20 (730 at age 70) during strenuous exercise. The corresponding rates for women are about 30 percent lower. Maximum metabolic rates of trained athletes can exceed 2000 W. We are interested in metabolic rate of the occupants of a building when we deal with heating and air conditioning because the metabolic rate represents the rate at which a body generates heat and dissipates it to the room. This body heat contributes to the heating in winter, but it adds to the cooling load of the building in summer.

**1-112C** The metabolic rate is proportional to the size of the body, and the metabolic rate of women, in general, is lower than that of men because of their smaller size. Clothing serves as insulation, and the thicker the clothing, the lower the environmental temperature that feels comfortable.

**1-113C** Asymmetric thermal radiation is caused by the *cold surfaces* of large windows, uninsulated walls, or cold products on one side, and the *warm surfaces* of gas or electric radiant heating panels on the walls or ceiling, solar heated masonry walls or ceilings on the other. Asymmetric radiation causes discomfort by exposing different sides of the body to surfaces at different temperatures and thus to different rates of heat loss or gain by radiation. A person whose left side is exposed to a cold window, for example, will feel like heat is being drained from that side of his or her body.

**1-114C** (a) Draft causes undesired local cooling of the human body by exposing parts of the body to high heat transfer coefficients. (b) Direct contact with *cold floor surfaces* causes localized discomfort in the feet by excessive heat loss by conduction, dropping the temperature of the bottom of the feet to uncomfortable levels.

**1-115C** Stratification is the formation of vertical still air layers in a room at difference temperatures, with highest temperatures occurring near the ceiling. It is likely to occur at places with high ceilings. It causes discomfort by exposing the head and the feet to different temperatures. This effect can be prevented or minimized by using destratification fans (ceiling fans running in reverse).

**1-116C** It is necessary to ventilate buildings to provide adequate fresh air and to get rid of excess carbon dioxide, contaminants, odors, and humidity. Ventilation increases the energy consumption for heating in winter by replacing the warm indoors air by the colder outdoors air. Ventilation also increases the energy consumption for cooling in summer by replacing the cold indoors air by the warm outdoors air. It is not a good idea to keep the bathroom fans on all the time since they will waste energy by expelling conditioned air (warm in winter and cool in summer) by the unconditioned outdoor air.

**1-117** The windows of a house in Atlanta are of double door type with wood frames and metal spacers. The average rate of heat loss through the windows in winter is to be determined.

**Assumptions** 1 Steady operating conditions exist. 2 Heat losses associated with the infiltration of air through the cracks/openings are not considered.

**Analysis** The rate of heat transfer through the window can be determined from

$$\dot{Q}_{\text{window, avg}} = U_{\text{overall}} A_{\text{window}} (T_i - T_o)$$

where  $T_i$  and  $T_o$  are the indoor and outdoor air temperatures, respectively,  $U_{\text{overall}}$  is the  $U$ -factor (the overall heat transfer coefficient) of the window, and  $A_{\text{window}}$  is the window area. Substituting,

$$\dot{Q}_{\text{window, avg}} = (2.50 \text{ W/m}^2 \cdot ^\circ\text{C})(20 \text{ m}^2)(22 - 11.3)^\circ\text{C} = 535 \text{ W}$$

**Discussion** This is the “average” rate of heat transfer through the window in winter in the absence of any infiltration.

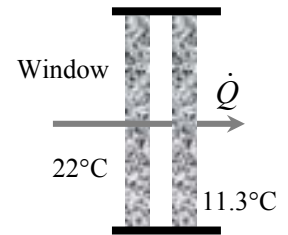

**1-118** Boiling experiments are conducted by heating water at 1 atm pressure with an electric resistance wire, and measuring the power consumed by the wire as well as temperatures. The boiling heat transfer coefficient is to be determined.

**Assumptions** 1 Steady operating conditions exist. 2 Heat losses from the water container are negligible.

**Analysis** The heat transfer area of the heater wire is

$$A = \pi DL = \pi(0.002 \text{ m})(0.70 \text{ m}) = 0.004398 \text{ m}^2$$

Noting that 4100 W of electric power is consumed when the heater surface temperature is  $120^\circ\text{C}$ , the boiling heat transfer coefficient is determined from Newton's law of cooling  $\dot{Q} = hA(T_s - T_{\text{sat}})$  to be

$$h = \frac{\dot{Q}}{A(T_s - T_{\text{sat}})} = \frac{4100 \text{ W}}{(0.004398 \text{ m}^2)(120 - 100)^\circ\text{C}} = 46,600 \text{ W/m}^2 \cdot ^\circ\text{C}$$

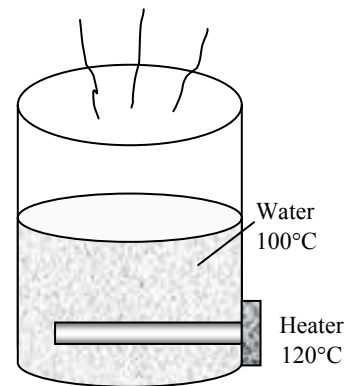



## Review Problems

**1-119** The power required to maintain the soldering iron tip at 400 °C is to be determined.

**Assumptions** **1** Steady operating conditions exist since the tip surface and the surrounding air temperatures remain constant. **2** The thermal properties of the tip and the convection heat transfer coefficient are constant and uniform. **3** The surrounding surfaces are at the same temperature as the air.

**Properties** The emissivity of the tip is given to be 0.80.

**Analysis** The total heat transfer area of the soldering iron tip is

$$\begin{aligned} A_s &= \pi D^2 / 4 + \pi DL \\ &= \pi(0.0025 \text{ m})^2 / 4 + \pi(0.0025 \text{ m})(0.02 \text{ m}) \\ &= 1.62 \times 10^{-4} \text{ m}^2 \end{aligned}$$

The rate of heat transfer by convection is

$$\begin{aligned} \dot{Q}_{\text{conv}} &= hA_s(T_{\text{tip}} - T_{\infty}) \\ &= (25 \text{ W/m}^2 \cdot \text{°C})(1.62 \times 10^{-4} \text{ m}^2)(400 - 20) \text{ °C} \\ &= 1.54 \text{ W} \end{aligned}$$

The rate of heat transfer by radiation is

$$\begin{aligned} \dot{Q}_{\text{rad}} &= \varepsilon \sigma A_s (T_{\text{tip}}^4 - T_{\text{surr}}^4) \\ &= (0.80)(5.67 \times 10^{-8} \text{ W/m}^2 \cdot \text{K}^4)(1.62 \times 10^{-4} \text{ m}^2)[(400 + 273)^4 - (20 + 273)^4] \text{ K}^4 \\ &= 1.45 \text{ W} \end{aligned}$$

Thus, the power required is equal to the total rate of heat transfer from the tip by both convection and radiation:

$$\dot{Q}_{\text{total}} = \dot{Q}_{\text{conv}} + \dot{Q}_{\text{rad}} = 1.54 \text{ W} + 1.45 \text{ W} = \mathbf{2.99 \text{ W}}$$

**Discussion** If the soldering iron tip is highly polished with an emissivity of 0.05, the power required to maintain the tip at 400 °C will reduce to 1.63 W, or by 45.5%.

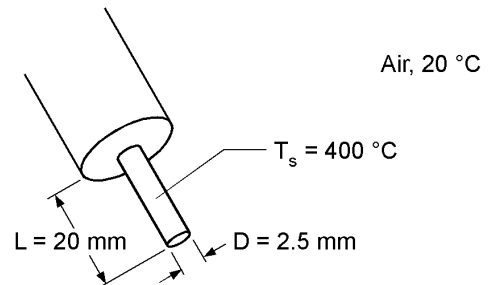

**1-120** A standing man is subjected to high winds and thus high convection coefficients. The rate of heat loss from this man by convection in still air at 20°C, in windy air, and the wind chill temperature are to be determined.

**Assumptions** **1** A standing man can be modeled as a 30-cm diameter, 170-cm long vertical cylinder with both the top and bottom surfaces insulated. **2** The exposed surface temperature of the person and the convection heat transfer coefficient is constant and uniform. **3** Heat loss by radiation is negligible.

**Analysis** The heat transfer surface area of the person is

$$A_s = \pi DL = \pi(0.3 \text{ m})(1.70 \text{ m}) = 1.60 \text{ m}^2$$

The rate of heat loss from this man by convection in still air is

$$\dot{Q}_{\text{still air}} = hA_s\Delta T = (15 \text{ W/m}^2\cdot\text{C})(1.60 \text{ m}^2)(34 - 20)^\circ\text{C} = \mathbf{336 \text{ W}}$$

In windy air it would be

$$\dot{Q}_{\text{windy air}} = hA_s\Delta T = (30 \text{ W/m}^2\cdot\text{C})(1.60 \text{ m}^2)(34 - 20)^\circ\text{C} = \mathbf{672 \text{ W}}$$

To lose heat at this rate in still air, the air temperature must be

$$672 \text{ W} = (hA_s\Delta T)_{\text{still air}} = (15 \text{ W/m}^2\cdot\text{C})(1.60 \text{ m}^2)(34 - T_{\text{effective}})^\circ\text{C}$$

which gives

$$T_{\text{effective}} = \mathbf{6^\circ\text{C}}$$

That is, the windy air at 20°C feels as cold as still air at 6°C as a result of the wind-chill effect.



Windy weather

**1-121** The backside of the thin metal plate is insulated and the front side is exposed to solar radiation. The surface temperature of the plate is to be determined when it stabilizes.

**Assumptions** **1** Steady operating conditions exist. **2** Heat transfer through the insulated side of the plate is negligible. **3** The heat transfer coefficient is constant and uniform over the plate. **4** Radiation heat transfer is negligible.

**Properties** The solar absorptivity of the plate is given to be  $\alpha = 0.7$ .

**Analysis** When the heat loss from the plate by convection equals the solar radiation absorbed, the surface temperature of the plate can be determined from

$$\dot{Q}_{\text{solarabsorbed}} = \dot{Q}_{\text{conv}}$$

$$\alpha\dot{Q}_{\text{solar}} = hA_s(T_s - T_o)$$

$$0.7 \times A \times 550 \text{ W/m}^2 = (25 \text{ W/m}^2 \cdot \text{C})A_s(T_s - 10)$$

Canceling the surface area  $A_s$  and solving for  $T_s$  gives

$$T_s = \mathbf{25.4^\circ\text{C}}$$

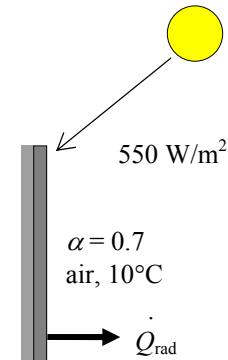

**1-122** A room is to be heated by 1 ton of hot water contained in a tank placed in the room. The minimum initial temperature of the water is to be determined if it to meet the heating requirements of this room for a 24-h period.

**Assumptions** **1** Water is an incompressible substance with constant specific heats. **2** Air is an ideal gas with constant specific heats. **3** The energy stored in the container itself is negligible relative to the energy stored in water. **4** The room is maintained at 20°C at all times. **5** The hot water is to meet the heating requirements of this room for a 24-h period.

**Properties** The specific heat of water at room temperature is  $c = 4.18 \text{ kJ/kg}\cdot^\circ\text{C}$  (Table A-9).

**Analysis** Heat loss from the room during a 24-h period is

$$Q_{\text{loss}} = (10,000 \text{ kJ/h})(24 \text{ h}) = 240,000 \text{ kJ}$$

Taking the contents of the room, including the water, as our system, the energy balance can be written as

$$\underbrace{E_{\text{in}} - E_{\text{out}}}_{\text{Net energy transfer by heat, work, and mass}} = \underbrace{\Delta E_{\text{system}}}_{\text{Change in internal, kinetic, potential, etc. energies}} \rightarrow -Q_{\text{out}} = \Delta U = (\Delta U)_{\text{water}} + (\Delta U)_{\text{air}} \quad \phi=0$$

or

$$-Q_{\text{out}} = [mc(T_2 - T_1)]_{\text{water}}$$

Substituting,

$$-240,000 \text{ kJ} = (1000 \text{ kg})(4.18 \text{ kJ/kg}\cdot^\circ\text{C})(20 - T_1)$$

It gives

$$T_1 = 77.4^\circ\text{C}$$

where  $T_1$  is the temperature of the water when it is first brought into the room.

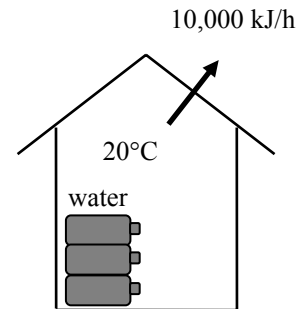

**1-123** The base surface of a cubical furnace is surrounded by black surfaces at a specified temperature. The net rate of radiation heat transfer to the base surface from the top and side surfaces is to be determined.

**Assumptions** **1** Steady operating conditions exist. **2** The top and side surfaces of the furnace closely approximate black surfaces. **3** The properties of the surfaces are constant.

**Properties** The emissivity of the base surface is  $\varepsilon = 0.4$ .

**Analysis** The base surface is completely surrounded by the top and side surfaces. Then using the radiation relation for a surface completely surrounded by another large (or black) surface, the net rate of radiation heat transfer from the top and side surfaces to the base is determined to be

$$\begin{aligned} \dot{Q}_{\text{rad,base}} &= \varepsilon A \sigma (T_{\text{base}}^4 - T_{\text{surr}}^4) \\ &= (0.4)(3 \times 3 \text{ m}^2)(5.67 \times 10^{-8} \text{ W/m}^2 \cdot \text{K}^4)[(1200 \text{ K})^4 - (800 \text{ K})^4] \\ &= 339,660 \text{ W} = \mathbf{340 \text{ kW}} \end{aligned}$$

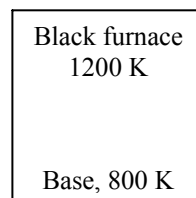

**1-124** Engine valves are to be heated in a heat treatment section. The amount of heat transfer, the average rate of heat transfer, the average heat flux, and the number of valves that can be heat treated daily are to be determined.

**Assumptions** Constant properties given in the problem can be used.

**Properties** The average specific heat and density of valves are given to be  $c_p = 440 \text{ J/kg}\cdot^\circ\text{C}$  and  $\rho = 7840 \text{ kg/m}^3$ .

**Analysis** (a) The amount of heat transferred to the valve is simply the change in its internal energy, and is determined from

$$\begin{aligned} Q &= \Delta U = mc_p(T_2 - T_1) \\ &= (0.0788 \text{ kg})(0.440 \text{ kJ/kg}\cdot^\circ\text{C})(800 - 40)^\circ\text{C} = \mathbf{26.35 \text{ kJ}} \end{aligned}$$

(b) The average rate of heat transfer can be determined from

$$\dot{Q}_{\text{avg}} = \frac{Q}{\Delta t} = \frac{26.35 \text{ kJ}}{5 \times 60 \text{ s}} = 0.0878 \text{ kW} = \mathbf{87.8 \text{ W}}$$

(c) The average heat flux is determined from

$$\dot{q}_{\text{ave}} = \frac{\dot{Q}_{\text{avg}}}{A_s} = \frac{\dot{Q}_{\text{avg}}}{2\pi DL} = \frac{87.8 \text{ W}}{2\pi(0.008 \text{ m})(0.1 \text{ m})} = \mathbf{1.75 \times 10^4 \text{ W/m}^2}$$

(d) The number of valves that can be heat treated daily is

$$\text{Number of valves} = \frac{(10 \times 60 \text{ min})(25 \text{ valves})}{5 \text{ min}} = \mathbf{3000 \text{ valves}}$$

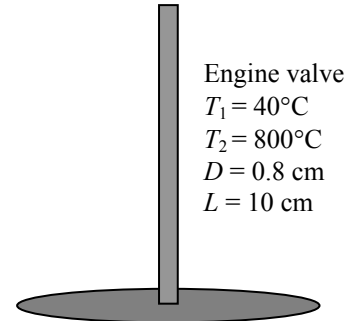

**1-125** The glass cover of a flat plate solar collector with specified inner and outer surface temperatures is considered. The fraction of heat lost from the glass cover by radiation is to be determined.

**Assumptions** **1** Steady operating conditions exist since the surface temperatures of the glass remain constant at the specified values. **2** Thermal properties of the glass are constant.

**Properties** The thermal conductivity of the glass is given to be  $k = 0.7 \text{ W/m}\cdot^\circ\text{C}$ .

**Analysis** Under steady conditions, the rate of heat transfer through the glass by conduction is

$$\dot{Q}_{\text{cond}} = kA \frac{\Delta T}{L} = (0.7 \text{ W/m}\cdot^\circ\text{C})(2.5 \text{ m}^2) \frac{(33 - 31)^\circ\text{C}}{0.006 \text{ m}} = 583 \text{ W}$$

The rate of heat transfer from the glass by convection is

$$\dot{Q}_{\text{conv}} = hA\Delta T = (10 \text{ W/m}^2\cdot^\circ\text{C})(2.5 \text{ m}^2)(31 - 15)^\circ\text{C} = 400 \text{ W}$$

Under steady conditions, the heat transferred through the cover by conduction should be transferred from the outer surface by convection and radiation. That is,

$$\dot{Q}_{\text{rad}} = \dot{Q}_{\text{cond}} - \dot{Q}_{\text{conv}} = 583 - 400 = 183 \text{ W}$$

Then the fraction of heat transferred by radiation becomes

$$f = \frac{\dot{Q}_{\text{rad}}}{\dot{Q}_{\text{cond}}} = \frac{183}{583} = \mathbf{0.314} \quad (\text{or } 31.4\%)$$

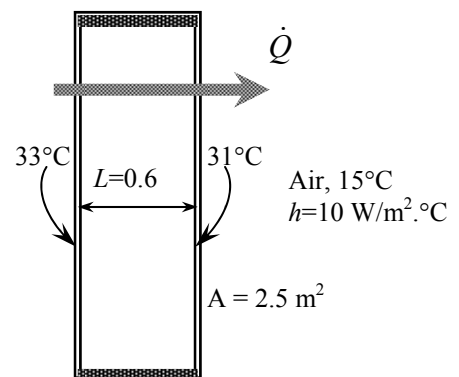

**1-126** The range of U-factors for windows are given. The range for the rate of heat loss through the window of a house is to be determined.

**Assumptions** 1 Steady operating conditions exist. 2 Heat losses associated with the infiltration of air through the cracks/openings are not considered.

**Analysis** The rate of heat transfer through the window can be determined from

$$\dot{Q}_{\text{window}} = U_{\text{overall}} A_{\text{window}} (T_i - T_o)$$

where  $T_i$  and  $T_o$  are the indoor and outdoor air temperatures, respectively,  $U_{\text{overall}}$  is the U-factor (the overall heat transfer coefficient) of the window, and  $A_{\text{window}}$  is the window area. Substituting,

Maximum heat loss:  $\dot{Q}_{\text{window, max}} = (6.25 \text{ W/m}^2 \cdot \text{°C})(1.2 \times 1.8 \text{ m}^2)[20 - (-8)]\text{°C} = \mathbf{378 \text{ W}}$

Minimum heat loss:  $\dot{Q}_{\text{window, min}} = (1.25 \text{ W/m}^2 \cdot \text{°C})(1.2 \times 1.8 \text{ m}^2)[20 - (-8)]\text{°C} = \mathbf{76 \text{ W}}$

**Discussion** Note that the rate of heat loss through windows of identical size may differ by a factor of 5, depending on how the windows are constructed.

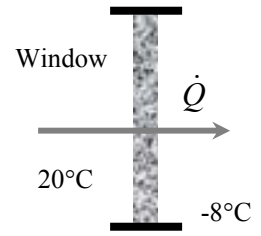

**1-127**  Prob. 1-126 is reconsidered. The rate of heat loss through the window as a function of the U-factor is to be plotted.

**Analysis** The problem is solved using EES, and the solution is given below.

**"GIVEN"**

- A=1.2\*1.8 [m^2]
- T\_1=20 [C]
- T\_2=-8 [C]
- U=1.25 [W/m^2-C]

**"ANALYSIS"**

$Q_{\text{dot\_window}} = U * A * (T_1 - T_2)$

U [W/m <sup>2</sup> .C]	Q <sub>window</sub> [W]
1.25	75.6
1.75	105.8
2.25	136.1
2.75	166.3
3.25	196.6
3.75	226.8
4.25	257
4.75	287.3
5.25	317.5
5.75	347.8
6.25	378

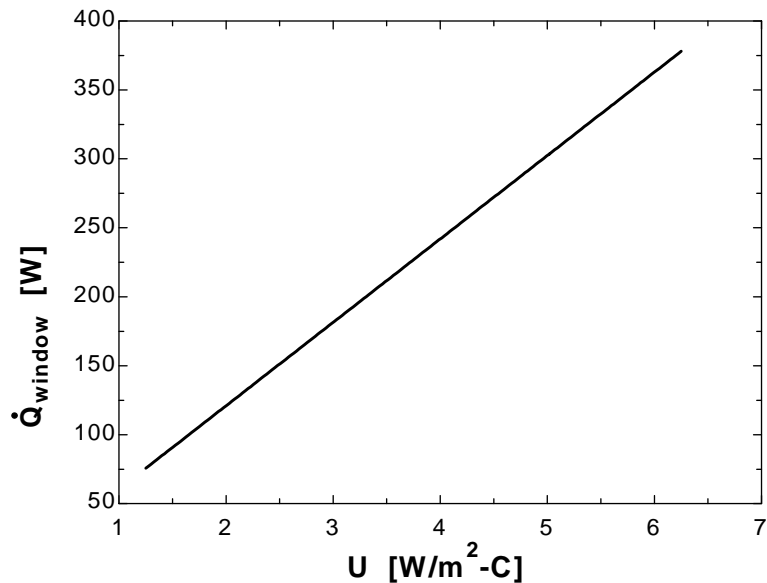

**1-128** An electric heater placed in a room consumes 500 W power when its surfaces are at 120°C. The surface temperature when the heater consumes 700 W is to be determined without and with the consideration of radiation.

**Assumptions** 1 Steady operating conditions exist. 2 The temperature is uniform over the surface.

**Analysis** (a) Neglecting radiation, the convection heat transfer coefficient is determined from

$$h = \frac{\dot{Q}}{A(T_s - T_\infty)} = \frac{500 \text{ W}}{(0.25 \text{ m}^2)(120 - 20)^\circ\text{C}} = 20 \text{ W/m}^2 \cdot ^\circ\text{C}$$

The surface temperature when the heater consumes 700 W is

$$T_s = T_\infty + \frac{\dot{Q}}{hA} = 20^\circ\text{C} + \frac{700 \text{ W}}{(20 \text{ W/m}^2 \cdot ^\circ\text{C})(0.25 \text{ m}^2)} = \mathbf{160^\circ\text{C}}$$

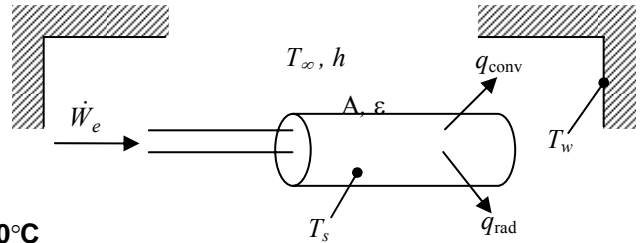

(b) Considering radiation, the convection heat transfer coefficient is determined from

$$\begin{aligned} h &= \frac{\dot{Q} - \epsilon A \sigma (T_s^4 - T_{\text{surr}}^4)}{A(T_s - T_\infty)} \\ &= \frac{500 \text{ W} - (0.75)(0.25 \text{ m}^2)(5.67 \times 10^{-8} \text{ W/m}^2 \cdot \text{K}^4)[(393 \text{ K})^4 - (283 \text{ K})^4]}{(0.25 \text{ m}^2)(120 - 20)^\circ\text{C}} \\ &= 12.58 \text{ W/m}^2 \cdot ^\circ\text{C} \end{aligned}$$

Then the surface temperature becomes

$$\begin{aligned} \dot{Q} &= hA(T_s - T_\infty) + \epsilon A \sigma (T_s^4 - T_{\text{surr}}^4) \\ 700 &= (12.58)(0.25)(T_s - 293) + (0.75)(0.25)(5.67 \times 10^{-8})[T_s^4 - (283 \text{ K})^4] \\ T_s &= 425.9 \text{ K} = \mathbf{152.9^\circ\text{C}} \end{aligned}$$

**Discussion** Neglecting radiation changed  $T_s$  by more than 7°C, so assumption is not correct in this case.

**1-129** An ice skating rink is located in a room is considered. The refrigeration load of the system and the time it takes to melt 3 mm of ice are to be determined.

**Assumptions 1** Steady operating conditions exist in part (a). **2** The surface is insulated on the back side in part (b).

**Properties** The heat of fusion and the density of ice are given to be 333.7 kJ/kg and 920 kg/m<sup>3</sup>, respectively.

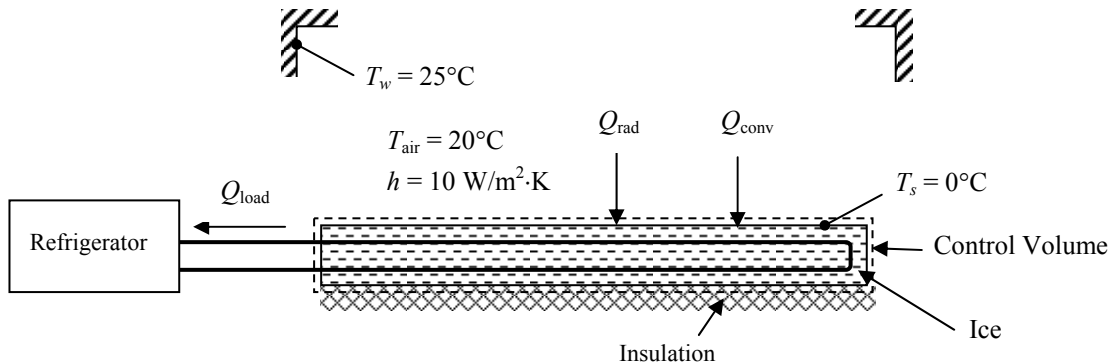

**Analysis (a)** The refrigeration load is determined from

$$\begin{aligned}\dot{Q}_{\text{load}} &= hA(T_{\text{air}} - T_s) + \varepsilon A \sigma (T_w^4 - T_s^4) \\ &= (10)(40 \times 12)(20 - 0) + (0.95)(40 \times 12)(5.67 \times 10^{-8}) [298^4 - 273^4] = \mathbf{156,300 \text{ W}}\end{aligned}$$

**(b)** The time it takes to melt 3 mm of ice is determined from

$$t = \frac{LW\delta\rho h_{if}}{\dot{Q}_{\text{load}}} = \frac{(40 \times 12 \text{ m}^2)(0.003 \text{ m})(920 \text{ kg/m}^3)(333.7 \times 10^3 \text{ J/kg})}{156,300 \text{ J/s}} = 2831 \text{ s} = \mathbf{47.2 \text{ min}}$$

**1-130** The surface temperature of an engine block that generates 50 kW of power output is to be determined.

**Assumptions 1** Steady operating conditions exist. **2** Temperature inside the engine compartment is uniform. **3** Heat transfer by radiation is not considered.

**Analysis** With a net engine efficiency of 35%, which means 65% of the generated power output are heat loss by convection:

$$\dot{Q}_{\text{conv}} = \dot{W}_{\text{out}}(1 - \eta) = (50 \text{ kW})(1 - 0.35) = 32.5 \text{ kW}$$

From Newton's law of cooling, the heat transfer by convection is given as

$$\dot{Q}_{\text{conv}} = hA_s(T_s - T_\infty)$$

Rearranging, the engine block surface temperature is

$$T_s = \frac{\dot{Q}_{\text{conv}}}{hA_s} + T_\infty = \frac{32.5 \times 10^3 \text{ W}}{(50 \text{ W/m}^2 \cdot ^\circ\text{C})(0.95 \text{ m}^2)} + 157^\circ\text{C} = \mathbf{841^\circ\text{C}}$$

**Discussion** Due to the complex geometry of the engine block, hot spots are likely to occur with temperatures much higher than 841 °C.

## Fundamentals of Engineering (FE) Exam Problems

**1-131** Which equation below is used to determine the heat flux for conduction?

- (a)  $-kA \frac{dT}{dx}$       (b)  $-k \text{ grad}T$       (c)  $h(T_2 - T_1)$       (d)  $\varepsilon\sigma T^4$       (e) None of them

*Answer* (b)  $-k \text{ grad}T$

**1-132** Which equation below is used to determine the heat flux for convection?

- (a)  $-kA \frac{dT}{dx}$       (b)  $-k \text{ grad}T$       (c)  $h(T_2 - T_1)$       (d)  $\varepsilon\sigma T^4$       (e) None of them

*Answer* (c)  $h(T_2 - T_1)$

**1-133** Which equation below is used to determine the heat flux emitted by thermal radiation from a surface?

- (a)  $-kA \frac{dT}{dx}$       (b)  $-k \text{ grad}T$       (c)  $h(T_2 - T_1)$       (d)  $\varepsilon\sigma T^4$       (e) None of them

*Answer* (d)  $\varepsilon\sigma T^4$

**1-134** Consider two different materials, A and B. The ratio of thermal conductivities is  $k_A/k_B = 13$ , the ratio of the densities is  $\rho_A/\rho_B = 0.045$ , and the ratio of specific heats is  $c_{p,A}/c_{p,B} = 16.9$ . The ratio of the thermal diffusivities  $\alpha_A/\alpha_B$  is

- (a) 4882      (b) 17.1      (c) 0.06      (d) 0.1      (e) 0.03

*Answer* (b) 17.1

**Solution** Solved by EES Software. Solutions can be verified by copying-and-pasting the following lines on a blank EES screen.

```
k_A/k_B=13
rho_A/rho_B=0.045
c_p_A/c_p_B=16.9
```

"From the definition of thermal diffusivity,  $\alpha = k/(\rho \cdot c_p)$ "  
 $\alpha_A/\alpha_B = k_A/k_B \cdot (1/\rho_A/\rho_B) \cdot (1/c_p_A/c_p_B)$

"Some Wrong Solutions with Common Mistakes"

```
W1_alpha_A/alpha_B=k_A/k_B*rho_A/rho_B*(1/c_p_A/c_p_B) "Not inverting density ratio"
W2_alpha_A/alpha_B=k_A/k_B*(1/rho_A/rho_B)*c_p_A/c_p_B "Not inverting specific heat ratio"
W3_alpha_A/alpha_B=1/(k_A/k_B)*(1/rho_A/rho_B)*(1/c_p_A/c_p_B) "Inverting conductivity ratio"
W4_alpha_A/alpha_B=1/(k_A/k_B*(1/rho_A/rho_B)*(1/c_p_A/c_p_B)) "Taking the inverse of result"
```



**1-135** A 2-kW electric resistance heater in a room is turned on and kept on for 50 minutes. The amount of energy transferred to the room by the heater is

- (a) 2 kJ                      (b) 100 kJ                      (c) 6000 kJ                      (d) 7200 kJ                      (e) 12,000 kJ

*Answer* (c) 6000 kJ

**Solution** Solved by EES Software. Solutions can be verified by copying-and-pasting the following lines on a blank EES screen.

```
We= 2 [kJ/s]
time=50*60 [s]
We_total=We*time [kJ]
```

"Wrong Solutions:"

```
W1_Etotal=We*time/60 "using minutes instead of s"
W2_Etotal=We "ignoring time"
```

**1-136** A hot 16 cm × 16 cm × 16 cm cubical iron block is cooled at an average rate of 80 W. The heat flux is

- (a) 195 W/m<sup>2</sup>                      (b) 521 W/m<sup>2</sup>                      (c) 3125 W/m<sup>2</sup>                      (d) 7100 W/m<sup>2</sup>                      (e) 19,500 W/m<sup>2</sup>

*Answer* (b) 521 W/m<sup>2</sup>

**Solution** Solved by EES Software. Solutions can be verified by copying-and-pasting the following lines on a blank EES screen.

```
a=0.16 [m]
Q_dot=80 [W]
A_s=6*a^2
q=Q_dot/A_s
```

"Some Wrong Solutions with Common Mistakes"

```
W1_q=Q_dot/a^2 "Using wrong equation for area"
W2_q=Q_dot/a^3 "Using volume instead of area"
```

**1-137** A 2-kW electric resistance heater submerged in 30-kg water is turned on and kept on for 10 min. During the process, 500 kJ of heat is lost from the water. The temperature rise of water is

- (a) 5.6°C      (b) 9.6°C      (c) 13.6°C      (d) 23.3°C      (e) 42.5°C

*Answer* (a) 5.6°C

**Solution** Solved by EES Software. Solutions can be verified by copying-and-pasting the following lines on a blank EES screen.

```
C=4.18 [kJ/kg-K]
m=30 [kg]
Q_loss=500 [kJ]
time=10*60 [s]
W_e=2 [kJ/s]
```

"Applying energy balance  $E_{in}-E_{out}=dE_{system}$  gives"

```
time*W_e-Q_loss = dU_system
dU_system=m*C*DELTAT
```

"Some Wrong Solutions with Common Mistakes:"

```
time*W_e = m*C*W1_T "Ignoring heat loss"
time*W_e+Q_loss = m*C*W2_T "Adding heat loss instead of subtracting"
time*W_e-Q_loss = m*1.0*W3_T "Using specific heat of air or not using specific heat"
```

**1-138** Eggs with a mass of 0.15 kg per egg and a specific heat of 3.32 kJ/kg·°C are cooled from 32°C to 10°C at a rate of 200 eggs per minute. The rate of heat removal from the eggs is

- (a) 7.3 kW      (b) 53 kW      (c) 17 kW      (d) 438 kW      (e) 37 kW

*Answer* (e) 37 kW

**Solution** Solved by EES Software. Solutions can be verified by copying-and-pasting the following lines on a blank EES screen.

```
C=3.32 [kJ/kg-K]
m_egg=0.15 [kg]
T1=32 [C]
T2=10 [C]
n=200 "eggs/min"
m=n*m_egg/60 "kg/s"
"Applying energy balance E_in-E_out=dE_system gives"
"-E_out = dU_system"
Qout=m*C*(T1-T2) "kJ/s"
"Some Wrong Solutions with Common Mistakes:"
W1_Qout = m*C*T1 "Using T1 only"
W2_Qout = m_egg*C*(T1-T2) "Using one egg only"
W3_Qout = m*C*T2 "Using T2 only"
W4_Qout=m_egg*C*(T1-T2)*60 "Finding kJ/min"
```

**1-139** Steel balls at 140°C with a specific heat of 0.50 kJ/kg·°C are quenched in an oil bath to an average temperature of 85°C at a rate of 35 balls per minute. If the average mass of steel balls is 1.2 kg, the rate of heat transfer from the balls to the oil is

- (a) 33 kJ/s      (b) 1980 kJ/s      (c) 49 kJ/s      (d) 30 kJ/s      (e) 19 kJ/s

*Answer* (e) 19 kJ/s

**Solution** Solved by EES Software. Solutions can be verified by copying-and-pasting the following lines on a blank EES screen.

```
c=0.50 [kJ/kg-K]
m1=1.2 [kg]
T1=140 [C]
T2=85 [C]
n=35 "balls/min"
m=n*m1/60 "kg/s"
"Applying energy balance E_in-E_out=dE_system gives"
"-E_out = dU_system"
Qout=m*c*(T1-T2) "kJ/s"
"Some Wrong Solutions with Common Mistakes:"
W1_Qout = m*c*T1 "Using T1 only"
W2_Qout = m1*c*(T1-T2) "Using one egg only"
W3_Qout = m*c*T2 "Using T2 only"
W4_Qout=m1*c*(T1-T2)*60 "Finding kJ/min"
```

**1-140** A cold bottled drink ( $m = 2.5$  kg,  $c_p = 4200$  J/kg·°C) at 5°C is left on a table in a room. The average temperature of the drink is observed to rise to 15°C in 30 minutes. The average rate of heat transfer to the drink is

- (a) 23 W      (b) 29 W      (c) 58 W      (d) 88 W      (e) 122 W

*Answer:* (c) 58 W

**Solution** Solved by EES Software. Solutions can be verified by copying-and-pasting the following lines on a blank EES screen.

```
c=4200 [J/kg-K]
m=2.5 [kg]
T1=5 [C]
T2=15 [C]
time = 30*60 [s]
"Applying energy balance E_in-E_out=dE_system gives"
Q=m*c*(T2-T1)
Qave=Q/time
"Some Wrong Solutions with Common Mistakes:"
W1_Qave = m*c*T1/time "Using T1 only"
W2_Qave = c*(T2-T1)/time "Not using mass"
W3_Qave = m*c*T2/time "Using T2 only"
```

**1-141** Water enters a pipe at 20°C at a rate of 0.50 kg/s and is heated to 60°C. The rate of heat transfer to the water is

- (a) 20 kW            (b) 42 kW            (c) 84 kW            (d) 126 kW            (e) 334 kW

*Answer* (c) 84 kW

**Solution** Solved by EES Software. Solutions can be verified by copying-and-pasting the following lines on a blank EES screen.

```
T_in=20 [C]
T_out=60 [C]
m_dot=0.50 [kg/s]
c_p=4.18 [kJ/kg-C]
Q_dot=m_dot*c_p*(T_out-T_in)
```

"Some Wrong Solutions with Common Mistakes"

W1\_Q\_dot=m\_dot\*(T\_out-T\_in) "Not using specific heat"

W2\_Q\_dot=c\_p\*(T\_out-T\_in) "Not using mass flow rate"

W3\_Q\_dot=m\_dot\*c\_p\*T\_out "Using exit temperature instead of temperature change"

**1-142** Air enters a 12-m-long, 7-cm-diameter pipe at 50°C at a rate of 0.06 kg/s. The air is cooled at an average rate of 400 W per m<sup>2</sup> surface area of the pipe. The air temperature at the exit of the pipe is

- (a) 4.3°C            (b) 17.5°C            (c) 32.5°C            (d) 43.4°C            (e) 45.8°C

*Answer* (c) 32.5°C

**Solution** Solved by EES Software. Solutions can be verified by copying-and-pasting the following lines on a blank EES screen.

```
L=12 [m]
D=0.07 [m]
T1=50 [C]
m_dot=0.06 [kg/s]
q=400 [W/m^2]
```

A=pi\*D\*L

Q\_dot=q\*A

c\_p=1007 [J/kg-C] "Table A-15"

Q\_dot=m\_dot\*c\_p\*(T1-T2)

"Some Wrong Solutions with Common Mistakes"

q=m\_dot\*c\_p\*(T1-W1\_T2) "Using heat flux, q instead of rate of heat transfer, Q\_dot"

Q\_dot=m\_dot\*4180\*(T1-W2\_T2) "Using specific heat of water"

Q\_dot=m\_dot\*c\_p\*W3\_T2 "Using exit temperature instead of temperature change"

**1-143** Heat is lost steadily through a 0.5-cm thick  $2\text{ m} \times 3\text{ m}$  window glass whose thermal conductivity is  $0.7\text{ W/m}\cdot^\circ\text{C}$ . The inner and outer surface temperatures of the glass are measured to be  $12^\circ\text{C}$  to  $9^\circ\text{C}$ . The rate of heat loss by conduction through the glass is

- (a) 420 W      (b) 5040 W      (c) 17,600 W      (d) 1256 W      (e) 2520 W

*Answer* (e) 2520 W

**Solution** Solved by EES Software. Solutions can be verified by copying-and-pasting the following lines on a blank EES screen.

```
A=3*2 [m^2]
L=0.005 [m]
T1=12 [C]
T2=9 [C]
k=0.7 [W/m-C]
Q=k*A*(T1-T2)/L
```

"Some Wrong Solutions with Common Mistakes:"

```
W1_Q=k*(T1-T2)/L "Not using area"
W2_Q=k*2*A*(T1-T2)/L "Using areas of both surfaces"
W3_Q=k*A*(T1+T2)/L "Adding temperatures instead of subtracting"
W4_Q=k*A*L*(T1-T2) "Multiplying by thickness instead of dividing by it"
```

**1-144** The East wall of an electrically heated house is 9 m long, 3 m high, and 0.35 m thick, and it has an effective thermal conductivity of  $0.7\text{ W/m}\cdot^\circ\text{C}$ . If the inner and outer surface temperatures of wall are  $15^\circ\text{C}$  and  $6^\circ\text{C}$ , the rate of heat loss through the wall is

- (a) 486 W      (b) 60 W      (c) 1134 W      (d) 972 W      (e) 2085 W

*Answer* (a) 486 W

**Solution** Solved by EES Software. Solutions can be verified by copying-and-pasting the following lines on a blank EES screen.

```
A=3*9 [m^2]
L=0.35 [m]
k=0.7 [W/m-C]
T1=15 [C]
T2=6 [C]
Q_cond=k*A*(T1-T2)/L
```

"Wrong Solutions:"

```
W1_Q=k*(T1-T2)/L "Not using area"
W2_Q=k*2*A*(T1-T2)/L "Using areas of both surfaces"
W3_Q=k*A*(T1+T2)/L "Adding temperatures instead of subtracting"
W4_Q=k*A*L*(T1-T2) "Multiplying by thickness instead of dividing by it"
```

**1-145** Steady heat conduction occurs through a 0.3-m thick 9 m by 3 m composite wall at a rate of 1.2 kW. If the inner and outer surface temperatures of the wall are 15°C and 7°C, the effective thermal conductivity of the wall is

- (a) 0.61 W/m·°C    (b) 0.83 W/m·°C    (c) 1.7 W/m·°C    (d) 2.2 W/m·°C    (e) 5.1 W/m·°C

*Answer* (c) 1.7 W/m·°C

**Solution** Solved by EES Software. Solutions can be verified by copying-and-pasting the following lines on a blank EES screen.

```
A=9*3 [m^2]
L=0.3 [m]
T1=15 [C]
T2=7 [C]
Q=1200 [W]
Q=k*A*(T1-T2)/L
```

"Wrong Solutions:"

```
Q=W1_k*(T1-T2)/L "Not using area"
Q=W2_k*2*A*(T1-T2)/L "Using areas of both surfaces"
Q=W3_k*A*(T1+T2)/L "Adding temperatures instead of subtracting"
Q=W4_k*A*L*(T1-T2) "Multiplying by thickness instead of dividing by it"
```

**1-146** Heat is lost through a brick wall ( $k = 0.72$  W/m·°C), which is 4 m long, 3 m wide, and 25 cm thick at a rate of 500 W. If the inner surface of the wall is at 22°C, the temperature at the midplane of the wall is

- (a) 0°C                      (b) 7.5°C                      (c) 11.0°C                      (d) 14.8°C                      (e) 22°C

*Answer* (d) 14.8°C

**Solution** Solved by EES Software. Solutions can be verified by copying-and-pasting the following lines on a blank EES screen.

```
k=0.72 [W/m-C]
Length=4 [m]
Width=3 [m]
L=0.25 [m]
Q_dot=500 [W]
T1=22 [C]
```

```
A=Length*Width
Q_dot=k*A*(T1-T_middle)/(0.5*L)
```

"Some Wrong Solutions with Common Mistakes"

```
Q_dot=k*A*(T1-W1_T_middle)/L "Using L instead of 0.5L"
W2_T_middle=T1/2 "Just taking the half of the given temperature"
```

**1-147** A 10-cm high and 20-cm wide circuit board houses on its surface 100 closely spaced chips, each generating heat at a rate of 0.12 W and transferring it by convection and radiation to the surrounding medium at 40°C. Heat transfer from the back surface of the board is negligible. If the combined convection and radiation heat transfer coefficient on the surface of the board is 22 W/m<sup>2</sup>·°C, the average surface temperature of the chips is

- (a) 41°C            (b) 54°C            (c) 67°C            (d) 76°C            (e) 82°C

*Answer* (c) 67°C

**Solution** Solved by EES Software. Solutions can be verified by copying-and-pasting the following lines on a blank EES screen.

```
A=0.1*0.2 [m^2]
Q= 100*0.12 [W]
Tair=40 [C]
h=22 [W/m^2-C]
Q= h*A*(Ts-Tair)
```

"Wrong Solutions:"

```
Q= h*(W1_Ts-Tair) "Not using area"
Q= h*2*A*(W2_Ts-Tair) "Using both sides of surfaces"
Q= h*A*(W3_Ts+Tair) "Adding temperatures instead of subtracting"
Q/100= h*A*(W4_Ts-Tair) "Considering 1 chip only"
```

**1-148** A 40-cm-long, 0.4-cm-diameter electric resistance wire submerged in water is used to determine the convection heat transfer coefficient in water during boiling at 1 atm pressure. The surface temperature of the wire is measured to be 114°C when a wattmeter indicates the electric power consumption to be 7.6 kW. The heat transfer coefficient is

- (a) 108 kW/m<sup>2</sup>·°C    (b) 13.3 kW/m<sup>2</sup>·°C    (c) 68.1 kW/m<sup>2</sup>·°C    (d) 0.76 kW/m<sup>2</sup>·°C    (e) 256 kW/m<sup>2</sup>·°C

*Answer* (a) 108 kW/m<sup>2</sup>·°C

**Solution** Solved by EES Software. Solutions can be verified by copying-and-pasting the following lines on a blank EES screen.

```
L=0.4 [m]
D=0.004 [m]
A=pi*D*L [m^2]
We=7.6 [kW]
Ts=114 [C]
Tf=100 [C] "Boiling temperature of water at 1 atm"
We= h*A*(Ts-Tf)
```

"Wrong Solutions:"

```
We= W1_h*(Ts-Tf) "Not using area"
We= W2_h*(L*pi*D^2/4)*(Ts-Tf) "Using volume instead of area"
We= W3_h*A*Ts "Using Ts instead of temp difference"
```

**1-149** Over 90 percent of the energy dissipated by an incandescent light bulb is in the form of heat, not light. What is the temperature of a vacuum-enclosed tungsten filament with an exposed surface area of  $2.03 \text{ cm}^2$  in a 100 W incandescent light bulb? The emissivity of tungsten at the anticipated high temperatures is about 0.35. Note that the light bulb consumes 100 W of electrical energy, and dissipates all of it by radiation.

- (a) 1870 K      (b) 2230 K      (c) 2640 K      (d) 3120 K      (e) 2980 K

*Answer* (b) 2230 K

**Solution** Solved by EES Software. Solutions can be verified by copying-and-pasting the following lines on a blank EES screen.

```
e =0.35
Q=100 [W]
A=2.03E-4 [m^2]
Q=e*A*sigma#*T^4
```

**1-150** Commercial surface coating processes often use infrared lamps to speed the curing of the coating. A 1-mm-thick, teflon ( $k = 0.45 \text{ W/m}\cdot\text{K}$ ) coating is applied to a  $4 \text{ m} \times 4 \text{ m}$  surface using this process. Once the coating reaches steady-state, the temperature of its two surfaces are  $50^\circ\text{C}$  and  $45^\circ\text{C}$ . What is the minimum rate at which power must be supplied to the infrared lamps steadily?

- (a) 36 kW      (b) 40 kW      (c) 44 kW      (d) 48 kW      (e) 52 kW

*Answer* (a) 36 kW

**Solution** Solved by EES Software. Solutions can be verified by copying-and-pasting the following lines on a blank EES screen.

```
k=0.45 [W/m-K]
A=16 [m^2]
t=0.001 [m]
dT=5 [C]
Q=k*A*dT/t
```



**1-151** A 10 cm × 12 cm × 14 cm rectangular prism object made of hardwood ( $\rho = 721 \text{ kg/m}^3$ ,  $c_p = 1.26 \text{ kJ/kg}\cdot^\circ\text{C}$ ) is cooled from 100°C to the room temperature of 20°C in 54 minutes. The approximate heat transfer coefficient during this process is

- (a) 0.47 W/m<sup>2</sup>·°C    (b) 5.5 W/m<sup>2</sup>·°C    (c) 8 W/m<sup>2</sup>·°C    (d) 11 W/m<sup>2</sup>·°C    (e) 17,830 W/m<sup>2</sup>·°C

*Answer* (d) 11 W/m<sup>2</sup>·°C

**Solution** Solved by EES Software. Solutions can be verified by copying-and-pasting the following lines on a blank EES screen.

```

a=0.10 [m]
b=0.12 [m]
c=0.14 [m]
rho=721 [kg/m^3]
c_p=1260 [J/kg-C]
T1=100 [C]
T2=20 [C]
time=54*60 [s]
V=a*b*c
m=rho*V
Q=m*c_p*(T1-T2)
Q_dot=Q/time
T_ave=1/2*(T1+T2)
T_infinity=T2
A_s=2*a*b+2*a*c+2*b*c
Q_dot=h*A_s*(T_ave-T_infinity)

```

"Some Wrong Solutions with Common Mistakes"

$Q\_dot=W1\_h*A\_s*(T1-T2)$  "Using T1 instead of T\_ave"

$Q\_dot=W2\_h*(T1-T2)$  "Not using A"

$Q=W3\_h*A\_s*(T1-T2)$  "Using Q instead of Q\_dot "

**1-152** A 25-cm diameter black ball at 130°C is suspended in air, and is losing heat to the surrounding air at 25°C by convection with a heat transfer coefficient of 12 W/m<sup>2</sup>·°C, and by radiation to the surrounding surfaces at 15°C. The total rate of heat transfer from the black ball is

- (a) 217 W      (b) 247 W      (c) 251 W      (d) 465 W      (e) 2365 W

*Answer:* (d) 465 W

**Solution** Solved by EES Software. Solutions can be verified by copying-and-pasting the following lines on a blank EES screen.

```
sigma=5.67E-8 [W/m^2-K^4]
eps=1
D=0.25 [m]
A=pi*D^2
h_conv=12 [W/m^2-C]
Ts=130 [C]
Tf=25 [C]
Tsurr=15 [C]
Q_conv=h_conv*A*(Ts-Tf)
Q_rad=eps*sigma*A*((Ts+273)^4-(Tsurr+273)^4)
Q_total=Q_conv+Q_rad
```

"Wrong Solutions:"

W1\_Q=Q\_conv "Ignoring radiation"

W2\_Q=Q\_rad "ignoring convection"

W3\_Q=Q\_conv+eps\*sigma\*A\*(Ts^4-Tsurr^4) "Using C in radiation calculations"

W4\_Q=Q\_total/A "not using area"

**1-153** A 3-m<sup>2</sup> black surface at 140°C is losing heat to the surrounding air at 35°C by convection with a heat transfer coefficient of 16 W/m<sup>2</sup>·°C, and by radiation to the surrounding surfaces at 15°C. The total rate of heat loss from the surface is

- (a) 5105 W      (b) 2940 W      (c) 3779 W      (d) 8819 W      (e) 5040 W

*Answer* (d) 8819 W

**Solution** Solved by EES Software. Solutions can be verified by copying-and-pasting the following lines on a blank EES screen.

```
sigma=5.67E-8 [W/m^2-K^4]
eps=1
A=3 [m^2]
h_conv=16 [W/m^2-C]
Ts=140 [C]
Tf=35 [C]
Tsurr=15 [C]
Q_conv=h_conv*A*(Ts-Tf)
Q_rad=eps*sigma*A*((Ts+273)^4-(Tsurr+273)^4)
Q_total=Q_conv+Q_rad
```

"Some Wrong Solutions with Common Mistakes:"

W1\_Q=Q\_conv "Ignoring radiation"

W2\_Q=Q\_rad "ignoring convection"

W3\_Q=Q\_conv+eps\*sigma\*A\*(Ts^4-Tsurr^4) "Using C in radiation calculations"

W4\_Q=Q\_total/A "not using area"

**1-154** A person's head can be approximated as a 25-cm diameter sphere at 35°C with an emissivity of 0.95. Heat is lost from the head to the surrounding air at 25°C by convection with a heat transfer coefficient of 11 W/m<sup>2</sup>·°C, and by radiation to the surrounding surfaces at 10°C. Disregarding the neck, determine the total rate of heat loss from the head.

- (a) 22 W            (b) 27 W            (c) 49 W            (d) 172 W            (e) 249 W

*Answer:* (c) 49 W

**Solution** Solved by EES Software. Solutions can be verified by copying-and-pasting the following lines on a blank EES screen.

```
sigma=5.67E-8 [W/m^2-K^4]
eps=0.95
D=0.25 [m]
A=pi*D^2
h_conv=11 [W/m^2-C]
Ts=35 [C]
Tf=25 [C]
Tsurr=10 [C]
Q_conv=h_conv*A*(Ts-Tf)
Q_rad=eps*sigma*A*((Ts+273)^4-(Tsurr+273)^4)
Q_total=Q_conv+Q_rad
```

"Wrong Solutions:"

W1\_Q=Q\_conv "Ignoring radiation"

W2\_Q=Q\_rad "ignoring convection"

W3\_Q=Q\_conv+eps\*sigma\*A\*(Ts^4-Tsurr^4) "Using C in radiation calculations"

W4\_Q=Q\_total/A "not using area"

**1-155** A 25-cm-long, 0.4-cm-diameter electric resistance wire is used to determine the convection heat transfer coefficient in air at 25°C experimentally. The surface temperature of the wire is measured to be 230°C when the electric power consumption is 180 W. If the radiation heat loss from the wire is calculated to be 60 W, the convection heat transfer coefficient is

- (a) 186 W/m<sup>2</sup>·°C    (b) 280 W/m<sup>2</sup>·°C    (c) 373 W/m<sup>2</sup>·°C    (d) 585 W/m<sup>2</sup>·°C    (e) 620 W/m<sup>2</sup>·°C

*Answer* (a) 186 W/m<sup>2</sup>·°C

**Solution** Solved by EES Software. Solutions can be verified by copying-and-pasting the following lines on a blank EES screen.

```
L=0.25 [m]
D=0.004 [m]
A=pi*D*L
We=180 [W]
Ts=230 [C]
Tf=25 [C]
Qrad = 60
We- Qrad = h*A*(Ts-Tf)
```

**“Some Wrong Solutions with Common Mistakes:”**

```
We- Qrad = W1_h*(Ts-Tf) "Not using area"
We- Qrad = W2_h*(L*D)*(Ts-Tf) "Using D*L for area"
We+ Qrad = W3_h*A*(Ts-Tf) "Adding Q_rad instead of subtracting"
We= W4_h*A*(Ts-Tf) "Disregarding Q_rad"
```

**1-156** A room is heated by a 1.2 kW electric resistance heater whose wires have a diameter of 4 mm and a total length of 3.4 m. The air in the room is at 23°C and the interior surfaces of the room are at 17°C. The convection heat transfer coefficient on the surface of the wires is 8 W/m<sup>2</sup>·°C. If the rates of heat transfer from the wires to the room by convection and by radiation are equal, the surface temperature of the wires is

- (a) 3534°C      (b) 1778°C      (c) 1772°C      (d) 98°C      (e) 25°C

*Answer* (b) 1778°C

**Solution** Solved by EES Software. Solutions can be verified by copying-and-pasting the following lines on a blank EES screen.

```
D=0.004 [m]
L=3.4 [m]
W_dot_e=1200 [W]
T_infinity=23 [C]
T_surr=17 [C]
h=8 [W/m^2-C]
```

```
A=pi*D*L
Q_dot_conv=W_dot_e/2
Q_dot_conv=h*A*(T_s-T_infinity)
```

"Some Wrong Solutions with Common Mistakes"

```
Q_dot_conv=h*A*(W1_T_s-T_surr) "Using T_surr instead of T_infinity"
Q_dot_conv/1000=h*A*(W2_T_s-T_infinity) "Using kW unit for the rate of heat transfer"
Q_dot_conv=h*(W3_T_s-T_infinity) "Not using surface area of the wires"
W_dot_e=h*A*(W4_T_s-T_infinity) "Using total heat transfer"
```

**1-157** A person standing in a room loses heat to the air in the room by convection and to the surrounding surfaces by radiation. Both the air in the room and the surrounding surfaces are at 20°C. The exposed surfaces of the person is 1.5 m<sup>2</sup> and has an average temperature of 32°C, and an emissivity of 0.90. If the rates of heat transfer from the person by convection and by radiation are equal, the combined heat transfer coefficient is

- (a) 0.008 W/m<sup>2</sup>·°C   (b) 3.0 W/m<sup>2</sup>·°C   (c) 5.5 W/m<sup>2</sup>·°C   (d) 8.3 W/m<sup>2</sup>·°C   (e) 10.9 W/m<sup>2</sup>·°C

*Answer* (e) 10.9 W/m<sup>2</sup>·°C

**Solution** Solved by EES Software. Solutions can be verified by copying-and-pasting the following lines on a blank EES screen.

```
T_infinity=20 [C]
T_surr=20 [C]
T_s=32 [C]
A=1.5 [m^2]
epsilon=0.90

sigma=5.67E-8 [W/m^2-K^4]
Q_dot_rad=epsilon*A*sigma*((T_s+273)^4-(T_surr+273)^4)
Q_dot_total=2*Q_dot_rad
Q_dot_total=h_combined*A*(T_s-T_infinity)
```

"Some Wrong Solutions with Common Mistakes"

```
Q_dot_rad=W1_h_combined*A*(T_s-T_infinity) "Using radiation heat transfer instead of total heat transfer"
Q_dot_rad_1=epsilon*A*sigma*(T_s^4-T_surr^4) "Using C unit for temperature in radiation calculation"
2*Q_dot_rad_1=W2_h_combined*A*(T_s-T_infinity)
```

**1-158** While driving down a highway early in the evening, the air flow over an automobile establishes an overall heat transfer coefficient of 18 W/m<sup>2</sup>·K. The passenger cabin of this automobile exposes 9 m<sup>2</sup> of surface to the moving ambient air. On a day when the ambient temperature is 33°C, how much cooling must the air conditioning system supply to maintain a temperature of 20°C in the passenger cabin?

- (a) 670 W   (b) 1284 W   (c) 2106 W   (d) 2565 W   (e) 3210 W

*Answer* (c) 2106 W

**Solution** Solved by EES Software. Solutions can be verified by copying-and-pasting the following lines on a blank EES screen.

```
h=18 [W/m^2-C]
A=9 [m^2]
T_1=33 [C]
T_2=20 [C]
Q=h*A*(T_2-T_1)
```

**1-159** On a still clear night, the sky appears to be a blackbody with an equivalent temperature of 250 K. What is the air temperature when a strawberry field cools to 0°C and freezes if the heat transfer coefficient between the plants and the air is 6 W/m<sup>2</sup>·°C because of a light breeze and the plants have an emissivity of 0.9?

- (a) 14°C      (b) 7°C      (c) 3°C      (d) 0°C      (e) -3°C

*Answer* (a) 14°C

**Solution** Solved by EES Software. Solutions can be verified by copying-and-pasting the following lines on a blank EES screen.

```
e=0.9
h=6 [W/m^2-K]
T_1=273 [K]
T_2=250 [K]
h*(T-T_1)=e*sigma#*(T_1^4-T_2^4)
```

### 1-160 . . . 1-163 Design and Essay Problems

