



**First-Order
Differential Equations**

EXERCISES FOR SECTION 1.1

- Note that $dy/dt = 0$ if and only if $y = -3$. Therefore, the constant function $y(t) = -3$ for all t is the only equilibrium solution.
- Note that $dy/dt = 0$ for all t only if $y^2 - 2 = 0$. Therefore, the only equilibrium solutions are $y(t) = -\sqrt{2}$ for all t and $y(t) = +\sqrt{2}$ for all t .
- The equilibrium solutions correspond to the values of P for which $dP/dt = 0$ for all t . For this equation, $dP/dt = 0$ for all t if $P = 0$ or $P = 230$.
 - The population is increasing if $dP/dt > 0$. That is, $P(1 - P/230) > 0$. Hence, $0 < P < 230$.
 - The population is decreasing if $dP/dt < 0$. That is, $P(1 - P/230) < 0$. Hence, $P > 230$ or $P < 0$. Since this is a population model, $P < 0$ might be considered “nonphysical.”
- The equilibrium solutions correspond to the values of P for which $dP/dt = 0$ for all t . For this equation, $dP/dt = 0$ for all t if $P = 0$, $P = 50$, or $P = 200$.
 - The population is increasing if $dP/dt > 0$. That is, $P < 0$ or $50 < P < 200$. Note, $P < 0$ might be considered “nonphysical” for a population model.
 - The population is decreasing if $dP/dt < 0$. That is, $0 < P < 50$ or $P > 200$.
- In order to answer the question, we first need to analyze the sign of the polynomial $y^3 - y^2 - 12y$. Factoring, we obtain

$$y^3 - y^2 - 12y = y(y^2 - y - 12) = y(y - 4)(y + 3).$$

- The equilibrium solutions correspond to the values of y for which $dy/dt = 0$ for all t . For this equation, $dy/dt = 0$ for all t if $y = -3$, $y = 0$, or $y = 4$.
 - The solution $y(t)$ is increasing if $dy/dt > 0$. That is, $-3 < y < 0$ or $y > 4$.
 - The solution $y(t)$ is decreasing if $dy/dt < 0$. That is, $y < -3$ or $0 < y < 4$.
- The rate of change of the amount of radioactive material is dr/dt . This rate is proportional to the amount r of material present at time t . With $-\lambda$ as the proportionality constant, we obtain the differential equation

$$\frac{dr}{dt} = -\lambda r.$$

Note that the minus sign (along with the assumption that λ is positive) means that the material decays.

- The only additional assumption is the initial condition $r(0) = r_0$. Consequently, the corresponding initial-value problem is

$$\frac{dr}{dt} = -\lambda r, \quad r(0) = r_0.$$

- The general solution of the differential equation $dr/dt = -\lambda r$ is $r(t) = r_0 e^{-\lambda t}$ where $r(0) = r_0$ is the initial amount.
 - We have $r(t) = r_0 e^{-\lambda t}$ and $r(5230) = r_0/2$. Thus

$$\frac{r_0}{2} = r_0 e^{-\lambda \cdot 5230}$$

$$\frac{1}{2} = e^{-\lambda \cdot 5230}$$

$$\ln \frac{1}{2} = -\lambda \cdot 5230$$

$$-\ln 2 = -\lambda \cdot 5230$$

because $\ln 1/2 = -\ln 2$. Thus,

$$\lambda = \frac{\ln 2}{5230} \approx 0.000132533.$$

- (b) We have $r(t) = r_0 e^{-\lambda t}$ and $r(8) = r_0/2$. By a computation similar to the one in part (a), we have

$$\lambda = \frac{\ln 2}{8} \approx 0.0866434.$$

- (c) If $r(t)$ is the number of atoms of C-14, then the units for dr/dt is number of atoms per year. Since $dr/dt = -\lambda r$, λ is “per year.” Similarly, for I-131, λ is “per day.” The unit of measurement of r does not matter.

- (d) We get the same answer because the original quantity, r_0 , cancels from each side of the equation. We are only concerned with the proportion remaining (one-half of the original amount).

8. We will solve for k percent. In other words, we want to find t such that $r(t) = (k/100)r_0$, and we know that $r(t) = r_0 e^{-\lambda t}$, where $\lambda = (\ln 2)/5230$ from Exercise 7. Thus we have

$$r_0 e^{-\lambda t} = \frac{k}{100} r_0$$

$$e^{-\lambda t} = \frac{k}{100}$$

$$-\lambda t = \ln \left(\frac{k}{100} \right)$$

$$t = \frac{-\ln \left(\frac{k}{100} \right)}{\lambda}$$

$$t = \frac{\ln 100 - \ln k}{\lambda}$$

$$t = \frac{5230(\ln 100 - \ln k)}{\ln 2}.$$

Thus, there is 88% left when $t \approx 964.54$ years; there is 12% left when $t \approx 15,998$ years; 2% left when $t \approx 29,517$ years; and 98% left when $t \approx 152.44$ years.

9. (a) The general solution of the exponential decay model $dr/dt = -\lambda r$ is $r(t) = r_0 e^{-\lambda t}$, where $r(0) = r_0$ is the initial amount. Since $r(\tau) = r_0/e$, we have

$$\frac{r_0}{e} = r_0 e^{-\lambda \tau}$$

4 CHAPTER 1 FIRST-ORDER DIFFERENTIAL EQUATIONS

$$e^{-1} = e^{-\lambda\tau}$$

$$-1 = -\lambda\tau$$

$$\tau = 1/\lambda.$$

- (b) Let h be the half-life, that is, the amount of time it takes for a quantity to decay to one-half of its original amount. Since $\lambda = 1/\tau$, we get

$$\frac{1}{2}r_0 = r_0e^{-\lambda h}$$

$$\frac{1}{2}r_0 = r_0e^{-h/\tau}$$

$$\frac{1}{2} = e^{-h/\tau}$$

$$-\ln 2 = -h/\tau.$$

Thus,

$$\tau = \frac{h}{\ln 2}$$

- (c) In Exercise 7, we stated that the half-life of Carbon 14 is 5230 years and that of Iodine 131 is 8 days. Therefore, the time constant for Carbon 14 is $5230/(\ln 2) \approx 7545$ years, and the time constant for Iodine 14 is $8/(\ln 2) \approx 11.5$ days.
- (d) To determine the equation of the line passing through $(0, 1)$ and tangent to the curve $r(t)/r_0$, we need to determine the slope of $r(t)/r_0$ at $t = 0$. Since

$$\frac{d}{dt} \frac{r(t)}{r_0} = \frac{d}{dt} e^{-\lambda t} = -\lambda e^{-\lambda t}$$

the slope at $t = 0$ is $-\lambda e^0 = -\lambda$. Thus, the equation of the tangent line is

$$y = -\lambda t + 1.$$

The line crosses the t -axis when $-\lambda t + 1 = 0$. We obtain $t = 1/\lambda$, which is the time constant τ .

- (e) An exponentially decaying function approaches zero asymptotically but is never actually equal to zero. Therefore, to say that an exponentially decaying function reaches its steady state in any amount of time is false. However, after five time constants, the original amount r_0 has decayed by a factor of $e^{-5} \approx 0.0067$. Therefore, less than one percent of the original quantity remains.
10. We use $\lambda \approx 0.0866434$ from part (b) of Exercise 7.
- (a) Since 72 hours is 3 days, we have $r(3) = r_0e^{-\lambda \cdot 3} = r_0e^{-.2598} \approx 0.77r_0$. Approximately 77% of the original amount arrives at the hospital.
- (b) Similarly, $r(5) = r_0e^{-\lambda \cdot 5} = r_0e^{-.4330} \approx 0.65r_0$. Approximately 65% of the original amount is left when it is used.
- (c) It will never *completely* decay since $e^{-\lambda t}$ is never zero. However, after one year, the proportion of the original amount left will be $e^{-\lambda \cdot 365} \approx 1.85 \times 10^{-14}$. Unless you start with a very large amount I-131, the amount left after one year should be safe to throw away. In practice, samples are stored for ten half-lives (80 days for I-131) and then disposed.

11. The solution of $dR/dt = kR$ with $R(0) = 4,000$ is

$$R(t) = 4,000 e^{kt}.$$

Setting $t = 6$, we have $R(6) = 4,000 e^{(k)(6)} = 130,000$. Solving for k , we obtain

$$k = \frac{1}{6} \ln \left(\frac{130,000}{4,000} \right) \approx 0.58.$$

Therefore, the rabbit population in the year 2010 would be $R(10) = 4,000 e^{(0.58 \cdot 10)} \approx 1,321,198$ rabbits.

12. (a) In this analysis, we consider only the case where v is positive. The right-hand side of the differential equation is a quadratic in v , and it is zero if $v = \sqrt{mg/k}$. Consequently, the solution $v(t) = \sqrt{mg/k}$ for all t is an equilibrium solution. If $0 \leq v < \sqrt{mg/k}$, then $dv/dt > 0$, and consequently, $v(t)$ is an increasing function. If $v > \sqrt{mg/k}$, then $dv/dt < 0$, and $v(t)$ is a decreasing function. In either case, $v(t) \rightarrow \sqrt{mg/k}$ as $t \rightarrow \infty$.

(b) See part (a).

13. The rate of learning is dL/dt . Thus, we want to know the values of L between 0 and 1 for which dL/dt is a maximum. As $k > 0$ and $dL/dt = k(1 - L)$, dL/dt attains its maximum value at $L = 0$.

14. (a) Let $L_1(t)$ be the solution of the model with $L_1(0) = 1/2$ (the student who starts out knowing one-half of the list) and $L_2(t)$ be the solution of the model with $L_2(0) = 0$ (the student who starts out knowing none of the list). At time $t = 0$,

$$\frac{dL_1}{dt} = 2(1 - L_1(0)) = 2\left(1 - \frac{1}{2}\right) = 1,$$

and

$$\frac{dL_2}{dt} = 2(1 - L_2(0)) = 2.$$

Hence, the student who starts out knowing none of the list learns faster at time $t = 0$.

- (b) The solution $L_2(t)$ with $L_2(0) = 0$ will learn one-half the list in some amount of time $t_* > 0$. For $t > t_*$, $L_2(t)$ will increase at exactly the same rate that $L_1(t)$ increases for $t > 0$. In other words, $L_2(t)$ increases at the same rate as $L_1(t)$ at t_* time units later. Hence, $L_2(t)$ will never catch up to $L_1(t)$ (although they both approach 1 as t increases). In other words, after a very long time $L_2(t) \approx L_1(t)$, but $L_2(t) < L_1(t)$.

15. (a) We have $L_B(0) = L_A(0) = 0$. So Aly's rate of learning at $t = 0$ is dL_A/dt evaluated at $t = 0$. At $t = 0$, we have

$$\frac{dL_A}{dt} = 2(1 - L_A) = 2.$$

Beth's rate of learning at $t = 0$ is

$$\frac{dL_B}{dt} = 3(1 - L_B)^2 = 3.$$

Hence Beth's rate is larger.

6 CHAPTER 1 FIRST-ORDER DIFFERENTIAL EQUATIONS

(b) In this case, $L_B(0) = L_A(0) = 1/2$. So Aly's rate of learning at $t = 0$ is

$$\frac{dL_A}{dt} = 2(1 - L_A) = 1$$

because $L_A = 1/2$ at $t = 0$. Beth's rate of learning at $t = 0$ is

$$\frac{dL_B}{dt} = 3(1 - L_B)^2 = \frac{3}{4}$$

because $L_B = 1/2$ at $t = 0$. Hence Aly's rate is larger.

(c) In this case, $L_B(0) = L_A(0) = 1/3$. So Aly's rate of learning at $t = 0$ is

$$\frac{dL_A}{dt} = 2(1 - L_A) = \frac{4}{3}.$$

Beth's rate of learning at $t = 0$ is

$$\frac{dL_B}{dt} = 3(1 - L_B)^2 = \frac{4}{3}.$$

They are both learning at the same rate when $t = 0$.

16. (a) Taking the logarithm of $s(t)$, we get

$$\begin{aligned} \ln s(t) &= \ln(s_0 e^{kt}) \\ &= \ln s_0 + \ln(e^{kt}) \\ &= kt + \ln s_0. \end{aligned}$$

The equation $\ln s(t) = kt + \ln s_0$ is the equation of a line where k is the slope and $\ln s_0$ is the vertical intercept.

(b) If we let $t = 0$ correspond to the year 1900, then $s(0) = s_0 = 5669$. By plotting the function $\ln s(t) = kt + \ln 5669$, we observe that the points roughly form a straight line, indicating that the expenditure is indeed growing at an exponential rate (see part (a)). The growth-rate coefficient $k = 0.05$ is the slope of the best fit line to the data.

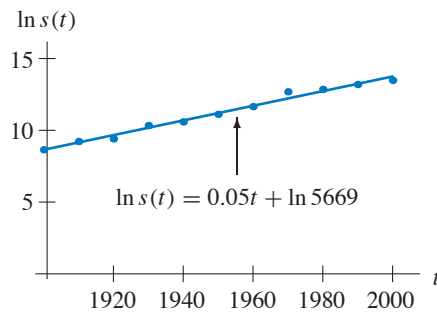

17. Let $P(t)$ be the population at time t , k be the growth-rate parameter, and N be the carrying capacity. The modified models are

(a) $dP/dt = k(1 - P/N)P - 100$

(b) $dP/dt = k(1 - P/N)P - P/3$

(c) $dP/dt = k(1 - P/N)P - a\sqrt{P}$, where a is a positive parameter.

18. (a) The differential equation is $dP/dt = 0.3P(1 - P/2500) - 100$. The equilibrium solutions of this equation correspond to the values of P for which $dP/dt = 0$ for all t . Using the quadratic formula, we obtain two such values, $P_1 \approx 396$ and $P_2 \approx 2104$. If $P > P_2$, $dP/dt < 0$, so $P(t)$ is decreasing. If $P_1 < P < P_2$, $dP/dt > 0$, so $P(t)$ is increasing. Hence the solution that satisfies the initial condition $P(0) = 2500$ decreases toward the equilibrium $P_2 \approx 2104$.

(b) The differential equation is $dP/dt = 0.3P(1 - P/2500) - P/3$. The equilibrium solutions of this equation are $P_1 \approx -277$ and $P_2 = 0$. If $P > 0$, $dP/dt < 0$, so $P(t)$ is decreasing. Hence, for $P(0) = 2500$, the population decreases toward $P = 0$ (extinction).

19. Several different models are possible. Let $R(t)$ denote the rhinoceros population at time t . The basic assumption is that there is a minimum threshold that the population must exceed if it is to survive. In terms of the differential equation, this assumption means that dR/dt must be negative if R is close to zero. Three models that satisfy this assumption are:

- If k is a growth-rate parameter and M is a parameter measuring when the population is “too small”, then

$$\frac{dR}{dt} = kR \left(\frac{R}{M} - 1 \right).$$

- If k is a growth-rate parameter and b is a parameter that determines the level the population will start to decrease ($R < b/k$), then

$$\frac{dR}{dt} = kR - b.$$

- If k is a growth-rate parameter and b is a parameter that determines the extinction threshold, then

$$\frac{dR}{dt} = kR - \frac{b}{R}.$$

In each case, if R is below a certain threshold, dR/dt is negative. Thus, the rhinos will eventually die out. The choice of which model to use depends on other assumptions. There are other equations that are also consistent with the basic assumption.

20. (a) The relative growth rate for the year 1990 is

$$\frac{1}{s(t)} \frac{ds}{dt} = \frac{1}{5.3} \left(\frac{7.6 - 3.5}{1991 - 1989} \right) \approx 0.387.$$

Hence, the relative growth rate for the year 1990 is 38.7%.

(b) If the quantity $s(t)$ grows exponentially, then we can model it as $s(t) = s_0 e^{kt}$, where s_0 and k are constants. Calculating the relative growth rate, we have

$$\frac{1}{s(t)} \frac{ds}{dt} = \frac{1}{s_0 e^{kt}} (k s_0 e^{kt}) = k.$$

Therefore, if a quantity grows exponentially, its relative growth rate is constant for all t .

(c)

Year	Rel. Growth Rate	Year	Rel. Growth Rate	Year	Rel. Growth Rate
1991	0.38	1997	0.23	2003	0.13
1992	0.38	1998	0.22	2004	0.13
1993	0.41	1999	0.24	2005	0.12
1994	0.38	2000	0.19	2006	0.09
1995	0.29	2001	0.12	2007	0.06
1996	0.24	2002	0.11		

(d) As shown in part (b), the number of subscriptions will grow exponentially if the relative growth rates are constant over time. The relative growth rates are (roughly) constant from 1991 to 1994, after which they drop off significantly.

(e) If a quantity $s(t)$ grows according to a logistic model, then

$$\frac{ds}{dt} = ks \left(1 - \frac{s}{N}\right),$$

so the relative growth rate

$$\frac{1}{s} \frac{ds}{dt} = k \left(1 - \frac{s}{N}\right).$$

The right-hand side is linear in s . In other words, if s is plotted on the horizontal axis and the relative growth rate is plotted on the vertical axis, we obtain a line. This line goes through the points $(0, k)$ and $(N, 0)$.

(f) From the data, we see that the line of best fit is

$$\frac{1}{s} \frac{ds}{dt} = 0.351972 - 0.001288s,$$

where $k = 0.351972$ and $-k/N = -0.001288$. Solving for N , we obtain $N \approx 273.27$ as the carrying capacity for the model.

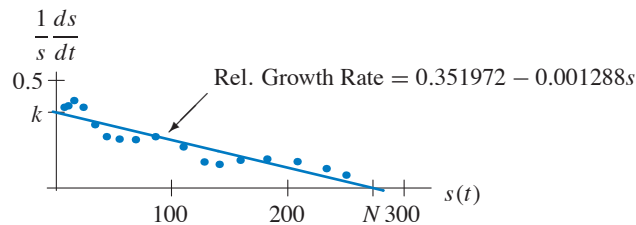

21. (a) The term governing the effect of the interaction of x and y on the rate of change of x is $+\beta xy$. Since this term is positive, the presence of y 's helps the x population grow. Hence, x is the predator. Similarly, the term $-\delta xy$ in the dy/dt equation implies that when $x > 0$, y 's grow more slowly, so y is the prey. If $y = 0$, then $dx/dt < 0$, so the predators will die out; thus, they must have insufficient alternative food sources. The prey has no limits on its growth other than the predator since, if $x = 0$, then $dy/dt > 0$ and the population increases exponentially.
- (b) Since $-\beta xy$ is negative and $+\delta xy$ is positive, x suffers due to its interaction with y and y benefits from its interaction with x . Hence, x is the prey and y is the predator. The predator has other sources of food than the prey since $dy/dt > 0$ even if $x = 0$. Also, the prey has a limit on its growth due to the $-\alpha x^2/N$ term.

22. (a) We consider dx/dt in each system. Setting $y = 0$ yields $dx/dt = 5x$ in system (i) and $dx/dt = x$ in system (ii). If the number x of prey is equal for both systems, dx/dt is larger in system (i). Therefore, the prey in system (i) reproduce faster if there are no predators.
- (b) We must see what effect the predators (represented by the y -terms) have on dx/dt in each system. Since the magnitude of the coefficient of the xy -term is larger in system (ii) than in system (i), y has a greater effect on dx/dt in system (ii). Hence the predators have a greater effect on the rate of change of the prey in system (ii).
- (c) We must see what effect the prey (represented by the x -terms) have on dy/dt in each system. Since x and y are both nonnegative, it follows that

$$-2y + \frac{1}{2}xy < -2y + 6xy,$$

and therefore, if the number of predators is equal for both systems, dy/dt is smaller in system (i). Hence more prey are required in system (i) than in system (ii) to achieve a certain growth rate.

23. (a) The independent variable is t , and x and y are dependent variables. Since each xy -term is positive, the presence of either species increases the rate of change of the other. Hence, these species cooperate. The parameter α is the growth-rate parameter for x , and γ is the growth-rate parameter for y . The parameter N represents the carrying capacity for x , but y has no carrying capacity. The parameter β measures the benefit to x of the interaction of the two species, and δ measures the benefit to y of the interaction.
- (b) The independent variable is t , and x and y are the dependent variables. Since both xy -terms are negative, these species compete. The parameter γ is the growth-rate coefficient for x , and α is the growth-rate parameter for y . Neither population has a carrying capacity. The parameter δ measures the harm to x caused by the interaction of the two species, and β measures the harm to y caused by the interaction.

EXERCISES FOR SECTION 1.2

1. (a) Let's check Bob's solution first. Since $dy/dt = 1$ and

$$\frac{y(t) + 1}{t + 1} = \frac{t + 1}{t + 1} = 1,$$

Bob's answer is correct.

Now let's check Glen's solution. Since $dy/dt = 2$ and

$$\frac{y(t) + 1}{t + 1} = \frac{2t + 2}{t + 1} = 2,$$

Glen's solution is also correct.

Finally let's check Paul's solution. We have $dy/dt = 2t$ on one hand and

$$\frac{y(t) + 1}{t + 1} = \frac{t^2 - 1}{t + 1} = t - 1$$

on the other. Paul is wrong.

10 CHAPTER 1 FIRST-ORDER DIFFERENTIAL EQUATIONS

(b) At first glance, they should have seen the equilibrium solution $y(t) = -1$ for all t because $dy/dt = 0$ for any constant function and $y = -1$ implies that

$$\frac{y+1}{t+1} = 0$$

independent of t .

Strictly speaking the differential equation is not defined for $t = -1$, and hence the solutions are not defined for $t = -1$.

2. We note that $dy/dt = 2e^{2t}$ for $y(t) = e^{2t}$. If $y(t) = e^{2t}$ is a solution to the differential equation, then we must have

$$\begin{aligned} 2e^{2t} &= 2y(t) - t + g(y(t)) \\ &= 2e^{2t} - t + g(e^{2t}). \end{aligned}$$

Hence, we need

$$g(e^{2t}) = t.$$

This equation is satisfied if we let $g(y) = (\ln y)/2$. In other words, $y(t) = e^{2t}$ is a solution of the differential equation

$$\frac{dy}{dt} = 2y - t + \frac{\ln y}{2}.$$

3. In order to find one such $f(t, y)$, we compute the derivative of $y(t)$. We obtain

$$\frac{dy}{dt} = \frac{de^{t^3}}{dt} = 3t^2e^{t^3}.$$

Now we replace e^{t^3} in the last expression by y and get the differential equation

$$\frac{dy}{dt} = 3t^2y.$$

4. Starting with $dP/dt = kP$, we divide both sides by P to obtain

$$\frac{1}{P} \frac{dP}{dt} = k.$$

Then integrating both sides with respect to t , we have

$$\int \frac{1}{P} \frac{dP}{dt} dt = \int k dt,$$

and changing variables on the left-hand side, we obtain

$$\int \frac{1}{P} dP = \int k dt.$$

(Typically, we jump to the equation above by “informally” multiplying both sides by dt .) Integrating, we get

$$\ln |P| = kt + c,$$

where c is an arbitrary constant. Exponentiating both sides gives

$$|P| = e^{kt+c} = e^c e^{kt}.$$

For population models we consider only $P \geq 0$, and the absolute value sign is unnecessary. Letting $P_0 = e^c$, we have

$$P(t) = P_0 e^{kt}.$$

In general, it is possible for $P(0)$ to be negative. In that case, $e^c = -P_0$, and $|P| = -P$. Once again we obtain

$$P(t) = P_0 e^{kt}.$$

5. (a) This equation is separable. (It is nonlinear and nonautonomous as well.)
 (b) We separate variables and integrate to obtain

$$\int \frac{1}{y^2} dy = \int t^2 dt$$

$$-\frac{1}{y} = \frac{t^3}{3} + c$$

$$y(t) = \frac{-1}{(t^3/3) + c},$$

where c is any real number. This function can also be written in the form

$$y(t) = \frac{-3}{t^3 + k}$$

where k is any constant. The constant function $y(t) = 0$ for all t is also a solution of this equation. It is the equilibrium solution at $y = 0$.

6. Separating variables and integrating, we obtain

$$\int \frac{1}{y} dy = \int t^4 dt$$

$$\ln |y| = \frac{t^5}{5} + c$$

$$|y| = c_1 e^{t^5/5},$$

where $c_1 = e^c$. As in Exercise 22, we can eliminate the absolute values by replacing the positive constant c_1 with $k = \pm c_1$. Hence, the general solution is

$$y(t) = k e^{t^5/5},$$

where k is any real number. Note that $k = 0$ gives the equilibrium solution.

7. We separate variables and integrate to obtain

$$\int \frac{dy}{2y+1} = \int dt.$$

We get

$$\frac{1}{2} \ln |2y+1| = t + c$$

$$|2y+1| = c_1 e^{2t},$$

where $c_1 = e^{2c}$. As in Exercise 22, we can drop the absolute value signs by replacing $\pm c_1$ with a new constant k_1 . Hence, we have

$$2y + 1 = k_1 e^{2t}$$

$$\frac{1}{2} (k_1 e^{2t} - 1)$$

8. Separating variables and integrating, we obtain

$$\begin{aligned}\int \frac{1}{2-y} dy &= \int dt \\ -\ln|2-y| &= t + c \\ \ln|2-y| &= -t + c_1,\end{aligned}$$

where we have replaced $-c$ with c_1 . Then

$$|2-y| = k_1 e^{-t},$$

where $k_1 = e^{c_1}$. We can drop the absolute value signs if we replace $\pm k_1$ with k_2 , that is, if we allow k_2 to be either positive or negative. Then we have

$$\begin{aligned}2-y &= k_2 e^{-t} \\ y &= 2 - k_2 e^{-t}.\end{aligned}$$

This could also be written as $y(t) = k e^{-t} + 2$, where we replace $-k_2$ with k . Note that $k = 0$ gives the equilibrium solution.

9. We separate variables and integrate to obtain

$$\begin{aligned}\int e^y dy &= \int dt \\ e^y &= t + c,\end{aligned}$$

where c is any constant. We obtain $y(t) = \ln(t + c)$.

10. We separate variables and obtain

$$\int \frac{dx}{1+x^2} = \int 1 dt.$$

Integrating both sides, we get

$$\arctan x = t + c,$$

where c is a constant. Hence, the general solution is

$$x(t) = \tan(t + c).$$

11. (a) This equation is separable.

(b) We separate variables and integrate to obtain

$$\begin{aligned}\int \frac{1}{y^2} dy &= \int (2t+3) dt \\ -\frac{1}{y} &= t^2 + 3t + k \\ y(t) &= \frac{-1}{t^2 + 3t + k},\end{aligned}$$

where k is any constant. The constant function $y(t) = 0$ for all t is also a solution of this equation. It is the equilibrium solution at $y = 0$.

12. Separating variables and integrating, we obtain

$$\int y \, dy = \int t \, dt$$

$$\frac{y^2}{2} = \frac{t^2}{2} + k$$

$$y^2 = t^2 + c,$$

where $c = 2k$. Hence,

$$y(t) = \pm\sqrt{t^2 + c},$$

where the initial condition determines the choice of sign.

13. First note that the differential equation is not defined if $y = 0$.

In order to separate the variables, we write the equation as

$$\frac{dy}{dt} = \frac{t}{y(t^2 + 1)}$$

to obtain

$$\int y \, dy = \int \frac{t}{t^2 + 1} \, dt$$

$$\frac{y^2}{2} = \frac{1}{2} \ln(t^2 + 1) + c,$$

where c is any constant. So we get

$$y^2 = \ln(k(t^2 + 1)),$$

where $k = e^{2c}$ (hence any positive constant). We have

$$y(t) = \pm\sqrt{\ln(k(t^2 + 1))},$$

where k is any positive constant and the sign is determined by the initial condition.

14. Separating variables and integrating, we obtain

$$\int y^{-1/3} \, dy = \int t \, dt$$

$$\frac{3}{2}y^{2/3} = \frac{t^2}{2} + k$$

$$y^{2/3} = \frac{t^2}{3} + c,$$

where $c = 2k/3$. Hence,

$$y(t) = \pm \left(\frac{t^2}{3} + c \right)^{3/2}.$$

Note that this form does not include the equilibrium solution $y = 0$.

15. First note that the differential equation is not defined for $y = -1/2$. We separate variables and integrate to obtain

$$\int (2y + 1) dy = \int dt$$

$$y^2 + y = t + k,$$

where k is any constant. So

$$y(t) = \frac{-1 \pm \sqrt{4t + 4k + 1}}{2} = \frac{-1 \pm \sqrt{4t + c}}{2},$$

where c is any constant and the \pm sign is determined by the initial condition.

We can rewrite the answer in the more simple form

$$y(t) = -\frac{1}{2} \pm \sqrt{t + c_1}$$

where $c_1 = k + 1/4$. If k can be any possible constant, then c_1 can be as well.

16. Note that there is an equilibrium solution of the form $y = -1/2$.

Separating variables and integrating, we have

$$\int \frac{1}{2y + 1} dy = \int \frac{1}{t} dt$$

$$\frac{1}{2} \ln |2y + 1| = \ln |t| + c$$

$$\ln |2y + 1| = (\ln t^2) + c$$

$$|2y + 1| = c_1 t^2,$$

where $c_1 = e^c$. We can eliminate the absolute value signs by allowing the constant c_1 to be either positive or negative. In other words, $2y + 1 = k_1 t^2$, where $k_1 = \pm c_1$. Hence,

$$y(t) = kt^2 - \frac{1}{2},$$

where $k = k_1/2$, or $y(t)$ is the equilibrium solution with $y = -1/2$.

17. First of all, the equilibrium solutions are $y = 0$ and $y = 1$. Now suppose $y \neq 0$ and $y \neq 1$. We separate variables to obtain

$$\int \frac{1}{y(1-y)} dy = \int dt = t + c,$$

where c is any constant. To integrate, we use partial fractions. Write

$$\frac{1}{y(1-y)} = \frac{A}{y} + \frac{B}{1-y}.$$

We must have $A = 1$ and $-A + B = 0$. Hence, $A = B = 1$ and

$$\frac{1}{y(1-y)} = \frac{1}{y} + \frac{1}{1-y}.$$

Consequently,

$$\int \frac{1}{y(1-y)} dy = \ln |y| - \ln |1-y| = \ln \left| \frac{y}{1-y} \right|.$$

After integration, we have

$$\ln \left| \frac{y}{1-y} \right| = t + c$$

$$\left| \frac{y}{1-y} \right| = c_1 e^t,$$

where $c_1 = e^c$ is any positive constant. To remove the absolute value signs, we replace the positive constant c_1 with a constant k that can be any real number and get

$$y(t) = \frac{ke^t}{1+ke^t},$$

where $k = \pm c_1$. If $k = 0$, we get the first equilibrium solution. The formula $y(t) = ke^t/(1+ke^t)$ yields all the solutions to the differential equation except for the equilibrium solution $y(t) = 1$.

18. Separating variables and integrating, we have

$$\int (1 + 3y^2) dy = \int 4t dt$$

$$y + y^3 = 2t^2 + c.$$

To express y as a function of t , we must solve a cubic. The equation for the roots of a cubic can be found in old algebra books or by asking a computer algebra program. But we do not learn a lot from the result.

19. The equation can be written in the form

$$\frac{dv}{dt} = (v+1)(t^2-2),$$

and we note that $v(t) = -1$ for all t is an equilibrium solution. Separating variables and integrating, we obtain

$$\int \frac{dv}{v+1} = \int t^2 - 2 dt$$

$$\ln |v+1| = \frac{t^3}{3} - 2t + c,$$

where c is any constant. Thus,

$$|v+1| = c_1 e^{-2t+t^3/3},$$

where $c_1 = e^c$. We can dispose of the absolute value signs by allowing the constant c_1 to be any real number. In other words,

$$v(t) = -1 + ke^{-2t+t^3/3},$$

where $k = \pm c_1$. Note that, if $k = 0$, we get the equilibrium solution.

20. Rewriting the equation as

$$\frac{dy}{dt} = \frac{1}{(t+1)(y+1)}$$

we separate variables and obtain

$$\int (y+1) dy = \int \frac{1}{t+1} dt.$$

Hence,

$$\frac{y^2}{2} + y = \ln|t+1| + k.$$

We can solve using the quadratic formula. We have

$$\begin{aligned} y(t) &= -1 \pm \sqrt{1 + 2 \ln|t+1| + 2k} \\ &= -1 \pm \sqrt{2 \ln|t+1| + c}, \end{aligned}$$

where $c = 1 + 2k$ is any constant and the choice of sign is determined by the initial condition.

21. The function $y(t) = 0$ for all t is an equilibrium solution.

Suppose $y \neq 0$ and separate variables. We get

$$\begin{aligned} \int y + \frac{1}{y} dy &= \int e^t dt \\ \frac{y^2}{2} + \ln|y| &= e^t + c, \end{aligned}$$

where c is any real constant. We cannot solve this equation for y , so we leave the expression for y in this implicit form. Note that the equilibrium solution $y = 0$ cannot be obtained from this implicit equation.

22. Since $y^2 - 4 = (y+2)(y-2)$, there are two equilibrium solutions, $y_1(t) = -2$ for all t and $y_2(t) = 2$ for all t . If $y \neq \pm 2$, we separate variables and obtain

$$\int \frac{dy}{y^2 - 4} = \int dt.$$

To integrate the left-hand side, we use partial fractions. If

$$\frac{1}{y^2 - 4} = \frac{A}{y+2} + \frac{B}{y-2},$$

then $A + B = 0$ and $2(B - A) = 1$. Hence, $A = -1/4$ and $B = 1/4$, and

$$\frac{1}{(y+2)(y-2)} = \frac{-1/4}{y+2} + \frac{1/4}{y-2}.$$

Consequently,

$$\int \frac{dy}{y^2 - 4} = -\frac{1}{4} \ln|y+2| + \frac{1}{4} \ln|y-2|.$$

Using this integral on the separated equation above, we get

$$\frac{1}{4} \ln \left| \frac{y-2}{y+2} \right| = t + c,$$

which yields

$$\left| \frac{y-2}{y+2} \right| = c_1 e^{4t},$$

where $c_1 = e^{4c}$. As in Exercise 22, we can drop the absolute value signs by replacing $\pm c_1$ with a new constant k . Hence, we have

$$\frac{y-2}{y+2} = k e^{4t}.$$

Solving for y , we obtain

$$y(t) = \frac{2(1 + k e^{4t})}{1 - k e^{4t}}.$$

Note that, if $k = 0$, we get the equilibrium solution $y_2(t)$. The formula $y(t) = 2(1 + k e^{4t})/(1 - k e^{4t})$ provides all of the solutions to the differential equation except the equilibrium solution $y_1(t)$.

- 23.** The constant function $w(t) = 0$ is an equilibrium solution. Suppose $w \neq 0$ and separate variables. We get

$$\begin{aligned} \int \frac{dw}{w} &= \int \frac{dt}{t} \\ \ln |w| &= \ln |t| + c \\ &= \ln c_1 |t|, \end{aligned}$$

where c is any constant and $c_1 = e^c$. Therefore,

$$|w| = c_1 |t|.$$

We can eliminate the absolute value signs by allowing the constant to assume positive or negative values. We have

$$w = kt,$$

where $k = \pm c_1$. Moreover, if $k = 0$ we get the equilibrium solution.

- 24.** Separating variables and integrating, we have

$$\begin{aligned} \int \cos y \, dy &= \int dx \\ \sin y &= x + c \\ y(x) &= \arcsin(x + c), \end{aligned}$$

where c is any real number. The branch of the inverse sine function that we use depends on the initial condition.

25. Separating variables and integrating, we have

$$\int \frac{1}{x} dx = \int -t dt$$

$$\ln |x| = -\frac{t^2}{2} + c$$

$$|x| = k_1 e^{-t^2/2},$$

where $k_1 = e^c$. We can eliminate the absolute value signs by allowing the constant k_1 to be either positive or negative. Thus, the general solution is

$$x(t) = k e^{-t^2/2}$$

where $k = \pm k_1$. Using the initial condition to solve for k , we have

$$\frac{1}{\sqrt{\pi}} = x(0) = k e^0 = k.$$

Therefore,

$$x(t) = \frac{e^{-t^2/2}}{\sqrt{\pi}}.$$

26. Separating variables and integrating, we have

$$\int \frac{1}{y} dy = \int t dt$$

$$\ln |y| = \frac{t^2}{2} + c$$

$$|y| = k_1 e^{t^2/2},$$

where $k_1 = e^c$. We can eliminate the absolute value signs by allowing the constant k_1 to be either positive or negative. Thus, the general solution can be written as

$$y(t) = k e^{t^2/2}.$$

Using the initial condition to solve for k , we have

$$3 = y(0) = k e^0 = k.$$

Therefore, $y(t) = 3e^{t^2/2}$.

27. Separating variables and integrating, we obtain

$$\int \frac{dy}{y^2} = - \int dt$$

$$-\frac{1}{y} = -t + c.$$

So we get

$$y = \frac{1}{t - c}.$$

Now we need to find the constant c so that $y(0) = 1/2$. To do this we solve

$$\frac{1}{2} = \frac{1}{0 - c}$$

and get $c = -2$. The solution of the initial-value problem is

$$y(t) = \frac{1}{t + 2}.$$

28. First we separate variables and integrate to obtain

$$\int y^{-3} dy = \int t^2 dt,$$

which yields

$$-\frac{y^{-2}}{2} = \frac{t^3}{3} + c.$$

Solving for y gives

$$y^2 = \frac{1}{c_1 - 2t^3/3},$$

where $c_1 = -2c$. So

$$y(t) = \pm \frac{1}{\sqrt{c_1 - 2t^3/3}}.$$

The initial value $y(0)$ is negative, so we choose the negative square root and obtain

$$y(t) = -\frac{1}{\sqrt{c_1 - 2t^3/3}}.$$

Using $-1 = y(0) = -1/\sqrt{c_1}$, we see that $c_1 = 1$ and the solution of the initial-value problem is

$$y(t) = -\frac{1}{\sqrt{1 - 2t^3/3}}.$$

29. We do not need to do any computations to solve this initial-value problem. We know that the constant function $y(t) = 0$ for all t is an equilibrium solution, and it satisfies the initial condition.

30. Rewriting the equation as

$$\frac{dy}{dt} = \frac{t}{(1 - t^2)y},$$

we separate variables and integrate obtaining

$$\int y \, dy = \int \frac{t}{1-t^2} \, dt$$

$$\frac{y^2}{2} = -\frac{1}{2} \ln |1-t^2| + c$$

$$y = \pm \sqrt{-\ln |1-t^2| + k}.$$

Since $y(0) = 4$ is positive, we use the positive square root and solve

$$4 = y(0) = \sqrt{-\ln |1| + k} = \sqrt{k}$$

for k . We obtain $k = 16$. Hence,

$$y(t) = \sqrt{16 - \ln(1-t^2)}.$$

We may replace $|1-t^2|$ with $(1-t^2)$ because the solution is only defined for $-1 < t < 1$.

31. From Exercise 7, we already know that the general solution is

$$y(t) = ke^{2t} - \frac{1}{2},$$

so we need only find the constant k for which $y(0) = 3$. We solve

$$3 = ke^0 - \frac{1}{2}$$

for k and obtain $k = 7/2$. The solution of the initial-value problem is

$$y(t) = \frac{7}{2}e^{2t} - \frac{1}{2}.$$

32. First we find the general solution by writing the differential equation as

$$\frac{dy}{dt} = (t+2)y^2,$$

separating variables, and integrating. We have

$$\int \frac{1}{y^2} \, dy = \int (t+2) \, dt$$

$$-\frac{1}{y} = \frac{t^2}{2} + 2t + c$$

$$= \frac{t^2 + 4t + c_1}{2},$$

where $c_1 = 2c$. Inverting and multiplying by -1 produces

$$y(t) = \frac{-2}{t^2 + 4t + c_1}.$$

Setting

$$1 = y(0) = \frac{-2}{c_1}$$

and solving for c_1 , we obtain $c_1 = -2$. So

$$y(t) = \frac{-2}{t^2 + 4t - 2}.$$

33. We write the equation in the form

$$\frac{dx}{dt} = \frac{t^2}{x(t^3 + 1)}$$

and separate variables to obtain

$$\begin{aligned} \int x \, dx &= \int \frac{t^2}{t^3 + 1} \, dt \\ \frac{x^2}{2} &= \frac{1}{3} \ln |t^3 + 1| + c, \end{aligned}$$

where c is a constant. Hence,

$$x^2 = \frac{2}{3} \ln |t^3 + 1| + 2c.$$

The initial condition $x(0) = -2$ implies

$$4 = (-2)^2 = \frac{2}{3} \ln |1| + 2c.$$

Thus, $c = 2$. Solving for $x(t)$, we choose the negative square root because $x(0)$ is negative, and we drop the absolute value sign because $t^3 + 1 > 0$ for t near 0. The result is

$$x(t) = -\sqrt{\frac{2}{3} \ln(t^3 + 1) + 4}.$$

34. Separating variables, we have

$$\begin{aligned} \int \frac{y \, dy}{1 - y^2} &= \int dt \\ &= t + c, \end{aligned}$$

where c is any constant. To integrate the left-hand side, we substitute $u = 1 - y^2$. Then $du = -2y \, dy$. We get

$$\int \frac{y \, dy}{1 - y^2} = -\frac{1}{2} \int \frac{du}{u} = -\frac{1}{2} \ln |u| = -\frac{1}{2} \ln |1 - y^2|.$$

Using this integral, we have

$$\begin{aligned} -\frac{1}{2} \ln |1 - y^2| &= t + c \\ |1 - y^2| &= c_1 e^{-2t}, \end{aligned}$$

22 CHAPTER 1 FIRST-ORDER DIFFERENTIAL EQUATIONS

where $c_1 = e^{-2t}$. As in Exercise 22, we can drop the absolute value signs by replacing $\pm c_1$ with a new constant k . Hence, we have

$$y(t) = \pm\sqrt{1 - ke^{-2t}}$$

Because $y(0)$ is negative, we use the negative square root and solve

$$-2 = y(0) = -\sqrt{1 - ke^0} = -\sqrt{1 - k}$$

for k . We obtain $k = -3$. Hence, $y(t) = -\sqrt{1 + 3e^{-2t}}$.

35. We separate variables to obtain

$$\int \frac{dy}{1 + y^2} = \int t \, dt$$

$$\arctan y = \frac{t^2}{2} + c,$$

where c is a constant. Hence the general solution is

$$y(t) = \tan\left(\frac{t^2}{2} + c\right).$$

Next we find c so that $y(0) = 1$. Solving

$$1 = \tan\left(\frac{0^2}{2} + c\right)$$

yields $c = \pi/4$, and the solution to the initial-value problem is

$$y(t) = \tan\left(\frac{t^2}{2} + \frac{\pi}{4}\right).$$

36. Separating variables and integrating, we obtain

$$\int (2y + 3) \, dy = \int dt$$

$$y^2 + 3y = t + c$$

$$y^2 + 3y - (t + c) = 0.$$

We can use the quadratic formula to obtain

$$y = -\frac{3}{2} \pm \sqrt{t + c_1},$$

where $c_1 = c + 9/4$. Since $y(0) = 1 > -3/2$ we take the positive square root and solve

$$1 = y(0) = -\frac{3}{2} + \sqrt{c_1},$$

so $c_1 = 25/4$. The solution to the initial-value problem is

$$y(t) = -\frac{3}{2} + \sqrt{t + \frac{25}{4}}.$$

37. Separating variables and integrating, we have

$$\int \frac{1}{y^2} dy = \int 2t + 3t^2 dt$$

$$-\frac{1}{y} = t^2 + t^3 + c$$

$$y = \frac{-1}{t^2 + t^3 + c}.$$

Using $y(1) = -1$ we have

$$-1 = y(1) = \frac{-1}{1 + 1 + c} = \frac{-1}{2 + c},$$

so $c = -1$. The solution to the initial-value problem is

$$y(t) = \frac{-1}{t^2 + t^3 - 1}.$$

38. Separating variables and integrating, we have

$$\int \frac{y}{y^2 + 5} dy = \int dt$$

$$= t + c,$$

where c is any constant. To integrate the left-hand side, we substitute $u = y^2 + 5$. Then $du = 2y dy$.

We have

$$\int \frac{y}{y^2 + 5} dy = \frac{1}{2} \int \frac{du}{u} = \frac{1}{2} \ln |u| = \frac{1}{2} \ln |y^2 + 5|.$$

Using this integral, we have

$$\frac{1}{2} \ln |y^2 + 5| = t + c$$

$$|y^2 + 5| = c_1 e^{2t},$$

where $c_1 = e^{2c}$. As in Exercise 26, we can drop the absolute value signs by replacing $\pm c_1$ with a new constant k . Hence, we have

$$y(t) = \pm \sqrt{ke^{2t} - 5}$$

Because $y(0)$ is negative, we use the negative square root and solve

$$-2 = y(0) = -\sqrt{ke^0 - 5} = -\sqrt{k - 5}$$

for k . We obtain $k = 9$. Hence, $y(t) = -\sqrt{9e^{2t} - 5}$.

39. Let $S(t)$ denote the amount of salt (in pounds) in the bucket at time t (in minutes). We derive a differential equation for S by considering the difference between the rate that salt is entering the bucket and the rate that salt is leaving the bucket. Salt is entering the bucket at the rate of $1/4$ pounds per minute. The rate that salt is leaving the bucket is the product of the concentration of salt in the

mixture and the rate that the mixture is leaving the bucket. The concentration is $S/5$, and the mixture is leaving the bucket at the rate of $1/2$ gallons per minute. We obtain the differential equation

$$\frac{dS}{dt} = \frac{1}{4} - \frac{S}{5} \cdot \frac{1}{2},$$

which can be rewritten as

$$\frac{dS}{dt} = \frac{5 - 2S}{20}.$$

This differential equation is separable, and we can find the general solution by integrating

$$\int \frac{1}{5 - 2S} dS = \int \frac{1}{20} dt.$$

We have

$$-\frac{\ln|5 - 2S|}{2} = \frac{t}{20} + c$$

$$\ln|5 - 2S| = -\frac{t}{10} + c_1$$

$$|5 - 2S| = c_2 e^{-t/10}.$$

We can eliminate the absolute value signs and determine c_2 using the initial condition $S(0) = 0$ (the water is initially free of salt). We have $c_2 = 5$, and the solution is

$$S(t) = 2.5 - 2.5e^{-t/10} = 2.5(1 - e^{-t/10}).$$

- (a) When $t = 1$, we have $S(1) = 2.5(1 - e^{-0.1}) \approx 0.238$ lbs.
- (b) When $t = 10$, we have $S(10) = 2.5(1 - e^{-1}) \approx 1.58$ lbs.
- (c) When $t = 60$, we have $S(60) = 2.5(1 - e^{-6}) \approx 2.49$ lbs.
- (d) When $t = 1000$, we have $S(1000) = 2.5(1 - e^{-100}) \approx 2.50$ lbs.
- (e) When t is very large, the $e^{-t/10}$ term is close to zero, so $S(t)$ is very close to 2.5 lbs. In this case, we can also reach the same conclusion by doing a qualitative analysis of the solutions of the equation. The constant solution $S(t) = 2.5$ is the only equilibrium solution for this equation, and by examining the sign of dS/dt , we see that all solutions approach $S = 2.5$ as t increases.

40. Rewrite the equation as

$$\frac{dC}{dt} = -k_1 C + (k_1 N + k_2 E),$$

separate variables, and integrate to obtain

$$\int \frac{1}{-k_1 C + (k_1 N + k_2 E)} dC = \int dt$$

$$-\frac{1}{k_1} \ln|-k_1 C + k_1 N + k_2 E| = t + c$$

$$-k_1 C + k_1 N + k_2 E = c_1 e^{-k_1 t},$$

where c_1 is a constant determined by the initial condition. Hence,

$$C(t) = N + \frac{k_2}{k_1}E - c_2e^{-k_1t},$$

where c_2 is a constant.

(a) Substituting the given values for the parameters, we obtain

$$C(t) = 600 - c_2e^{-0.1t},$$

and the initial condition $C(0) = 150$ gives $c_2 = 450$, which implies that

$$C(t) = 600 - 450e^{-0.1t}.$$

Hence, $C(2) \approx 232$.

(b) Using part (a), $C(5) \approx 328$.

(c) When t is very large, $e^{-0.1t}$ is very close to zero, so $C(t) \approx 600$. (We could also obtain this conclusion by doing a qualitative analysis of the solutions.)

(d) Using the new parameter values and $C(0) = 600$ yields

$$C(t) = 300 + 300e^{-0.1t},$$

so $C(1) \approx 571$, $C(5) \approx 482$, and $C(t) \rightarrow 300$ as $t \rightarrow \infty$.

(e) Again changing the parameter values and using $C(0) = 600$, we have

$$C(t) = 500 + 100e^{-0.1t},$$

so $C(1) \approx 590$, $C(5) \approx 560$, and $C(t) \rightarrow 500$ as $t \rightarrow \infty$.

41. (a) If we let k denote the proportionality constant in Newton's law of cooling, the differential equation satisfied by the temperature T of the chocolate is

$$\frac{dT}{dt} = k(T - 70).$$

We also know that $T(0) = 170$ and that $dT/dt = -20$ at $t = 0$. Therefore, we obtain k by evaluating the differential equation at $t = 0$. We have

$$-20 = k(170 - 70),$$

so $k = -0.2$. The initial-value problem is

$$\frac{dT}{dt} = -0.2(T - 70), \quad T(0) = 170.$$

(b) We can solve the initial-value problem in part (a) by separating variables. We have

$$\int \frac{dT}{T - 70} = \int -0.2 dt$$

$$\ln|T - 70| = -0.2t + k$$

$$|T - 70| = ce^{-0.2t}.$$

Since the temperature of the chocolate cannot become lower than the temperature of the room, we can ignore the absolute value and conclude

$$T(t) = 70 + ce^{-0.2t}.$$

Now we use the initial condition $T(0) = 170$ to find the constant c because

$$170 = T(0) = 70 + ce^{-0.2(0)},$$

which implies that $c = 100$. The solution is

$$T = 70 + 100e^{-0.2t}.$$

In order to find t so that the temperature is 110° F, we solve

$$110 = 70 + 100e^{-0.2t}$$

for t obtaining

$$\frac{2}{5} = e^{-0.2t}$$

$$\ln \frac{2}{5} = -0.2t$$

so that

$$t = \frac{\ln(2/5)}{-0.2} \approx 4.6.$$

- 42.** Let t be time measured in minutes and let $H(t)$ represent the hot sauce in the chili measured in teaspoons at time t . Then $H(0) = 12$.

The pot contains 32 cups of chili, and chili is removed from the pot at the rate of 1 cup per minute. Since each cup of chili contains $H/32$ teaspoons of hot sauce, the differential equation is

$$\frac{dH}{dt} = -\frac{H}{32}.$$

The general solution of this equation is

$$H(t) = ke^{-t/32}.$$

(We could solve this differential equation by separation of variables, but this is also the equation for which we guessed solutions in Section 1.1.) Since $H(0) = 12$, we get the solution

$$H(t) = 12e^{-t/32}.$$

We wish to find t such that $H(t) = 4$ (two teaspoons per gallon in two gallons). We have

$$12e^{-t/32} = 4$$

$$-\frac{t}{32} = \ln \frac{1}{3}$$

$$t = 32 \ln 3.$$

So, $t \approx 35.16$ minutes. A reasonable approximation is 35 minutes and in that time 35 cups will have been eaten.

43. (a) We rewrite the differential equation as

$$\frac{dv}{dt} = g \left(1 - \frac{k}{mg} v^2 \right).$$

Letting $\alpha = \sqrt{k/(mg)}$ and separating variables, we have

$$\int \frac{dv}{1 - \alpha^2 v^2} = \int g dt.$$

Now we use the partial fractions decomposition

$$\frac{1}{1 - \alpha^2 v^2} = \frac{1/2}{1 + \alpha v} + \frac{1/2}{1 - \alpha v}$$

to obtain

$$\int \frac{dv}{1 + \alpha v} + \int \frac{dv}{1 - \alpha v} = 2gt + c,$$

where c is an arbitrary constant. Integrating the left-hand side, we get

$$\frac{1}{\alpha} \left(\ln |1 + \alpha v| - \ln |1 - \alpha v| \right) = 2gt + c.$$

Multiplying through by α and using the properties of logarithms, we have

$$\ln \left| \frac{1 + \alpha v}{1 - \alpha v} \right| = 2\alpha gt + c.$$

Exponentiating and eliminating the absolute value signs yields

$$\frac{1 + \alpha v}{1 - \alpha v} = C e^{2\alpha gt}.$$

Solving for v , we have

$$v = \frac{1}{\alpha} \frac{C e^{2\alpha gt} - 1}{C e^{2\alpha gt} + 1}.$$

Recalling that $\alpha = \sqrt{k/(mg)}$, we see that $\alpha g = \sqrt{kg/m}$, and we get

$$v(t) = \sqrt{\frac{mg}{k}} \left(\frac{C e^{2\sqrt{(kg/m)}t} - 1}{C e^{2\sqrt{(kg/m)}t} + 1} \right).$$

Note: If we assume that $v(0) = 0$, then $C = 1$. The solution to this initial-value problem is often expressed in terms of the hyperbolic tangent function as

$$v = \sqrt{\frac{mg}{k}} \tanh \left(\sqrt{\frac{kg}{m}} t \right).$$

(b) The fraction in the parentheses of the general solution

$$v(t) = \sqrt{\frac{mg}{k}} \left(\frac{C e^{2\sqrt{(kg/m)}t} - 1}{C e^{2\sqrt{(kg/m)}t} + 1} \right),$$

tends to 1 as $t \rightarrow \infty$, so the limit of $v(t)$ as $t \rightarrow \infty$ is $\sqrt{mg/k}$.

EXERCISES FOR SECTION 1.3

1.

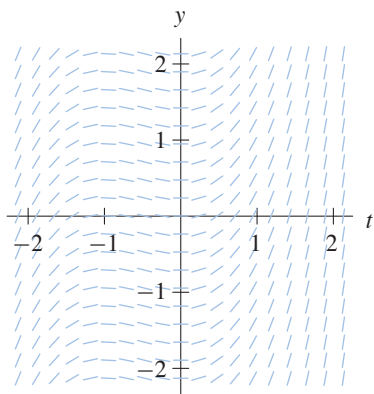

2.

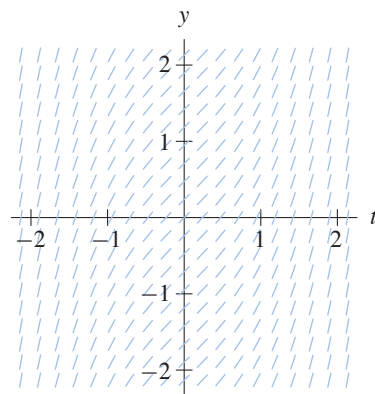

3.

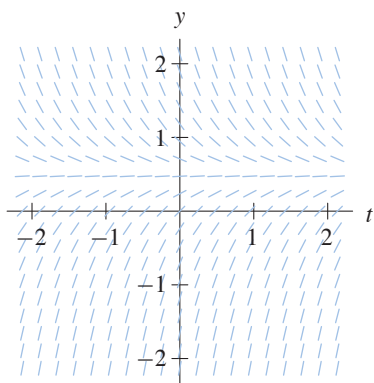

4.

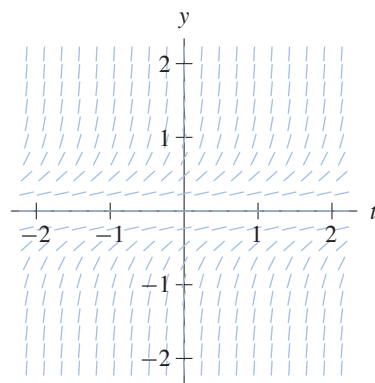

5.

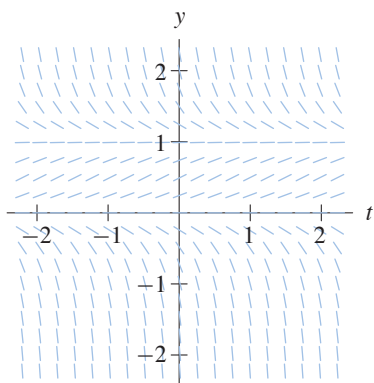

6.

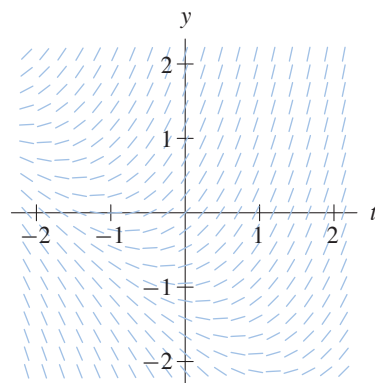

7. (a)

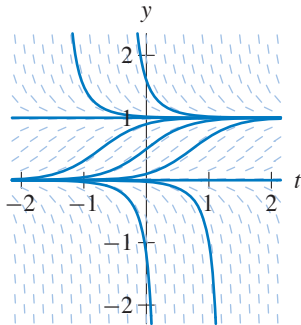

(b) The solution with $y(0) = 1/2$ approaches the equilibrium value $y = 1$ from below as t increases. It decreases toward $y = 0$ as t decreases.

8. (a)

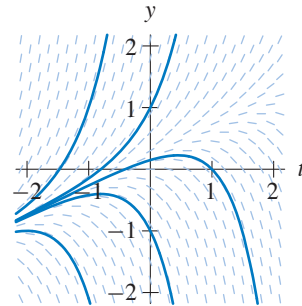

(b) The solution $y(t)$ with $y(0) = 1/2$ increases with $y(t) \rightarrow \infty$ as t increases. As t decreases, $y(t) \rightarrow -\infty$.

9. (a)

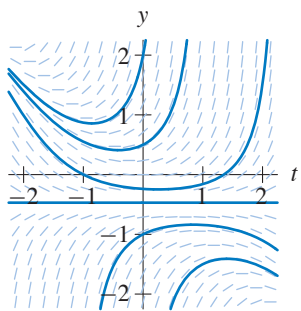

(b) The solution $y(t)$ with $y(0) = 1/2$ has $y(t) \rightarrow \infty$ both as t increases and as t decreases.

10. (a)

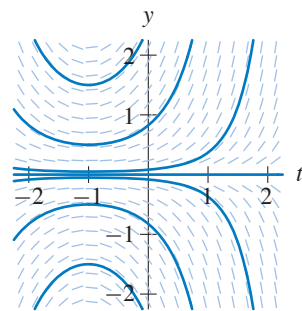

(b) The solution $y(t)$ with $y(0) = 1/2$ has $y(t) \rightarrow \infty$ both as t increases and as t decreases.

11. (a) On the line $y = 3$ in the ty -plane, all of the slope marks have slope -1 .
 (b) Because f is continuous, if y is close to 3, then $f(t, y) < 0$. So any solution close to $y = 3$ must be decreasing. Therefore, solutions $y(t)$ that satisfy $y(0) < 3$ can never be larger than 3 for $t > 0$, and consequently $y(t) < 3$ for all t .
12. (a) Since $y(t) = 2$ for all t is a solution and $dy/dt = 0$ for all t , $f(t, y(t)) = f(t, 2) = 0$ for all t .
 (b) Therefore, the slope marks all have zero slope along the horizontal line $y = 2$.
 (c) If the graphs of solutions cannot cross in the ty -plane, then the graph of a solution must stay on the same side of the line $y = 2$ as it is at time $t = 0$. In Section 1.5, we discuss conditions that guarantee that graphs of solutions do not cross.
13. The slope field in the ty -plane is constant along vertical lines.

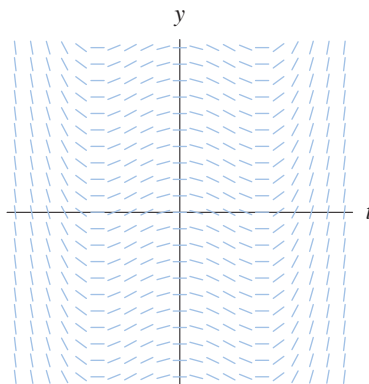

14. Because f depends only on y (the equation is autonomous), the slope field is constant along horizontal lines in the ty -plane. The roots of f correspond to equilibrium solutions. If $f(y) > 0$, the corresponding lines in the slope field have positive slope. If $f(y) < 0$, the corresponding lines in the slope field have negative slope.

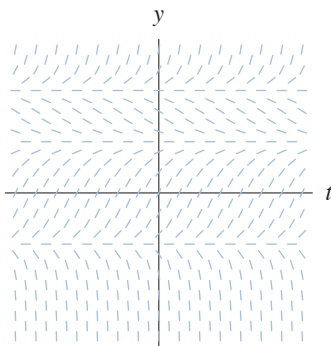

15.

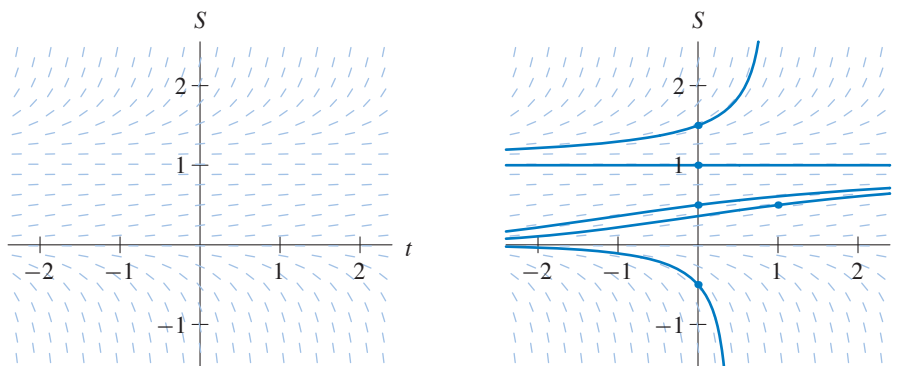

16. (a) This slope field is constant along horizontal lines, so it corresponds to an autonomous equation. The autonomous equations are (i), (ii), and (iii). This field does not correspond to equation (ii) because it has the equilibrium solution $y = -1$. The slopes are negative for $y < -1$. Consequently, this field corresponds to equation (iii).

- (b) Note that the slopes are constant along vertical lines—lines along which t is constant, so the right-hand side of the corresponding equation depends only on t . The only choices are equations (iv) and (viii). Since the slopes are negative for $-\sqrt{2} < t < \sqrt{2}$, this slope field corresponds to equation (viii).
- (c) This slope field depends both on y and on t , so it can only correspond to equations (v), (vi), or (vii). Since this field has the equilibrium solution $y = 0$, this slope field corresponds to equation (v).
- (d) This slope field also depends on both y and on t , so it can only correspond to equations (v), (vi), or (vii). This field does not correspond to equation (v) because $y = 0$ is not an equilibrium solution. Since the slopes are nonnegative for $y > -1$, this slope field corresponds to equation (vi).
17. (a) Because the slope field is constant on vertical lines, the given information is enough to draw the entire slope field.
- (b) The solution with initial condition $y(0) = 2$ is a vertical translation of the given solution. We only need change the “constant of integration” so that $y(0) = 2$.

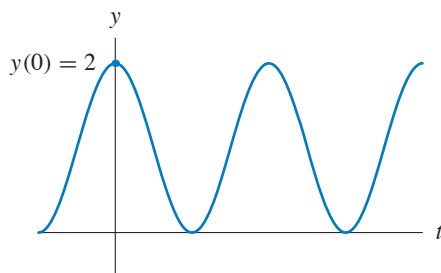

18. (a) Because the equation is autonomous, the slope field is constant on horizontal lines, so this solution provides enough information to sketch the slope field on the entire upper half plane. Also, if we assume that f is continuous, then the slope field on the line $y = 0$ must be horizontal.
- (b) The solution with initial condition $y(0) = 2$ is a translate to the left of the given solution.

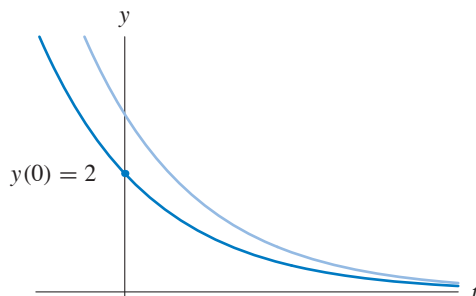

19. (a) Even though the question only asks for slope fields in this part, we superimpose the graphs of the equilibrium solutions on the fields to illustrate the equilibrium solutions (see part (b)).

$$I_1 = -0.1$$

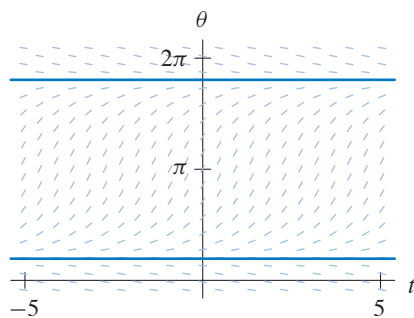

$$I_2 = 0.0$$

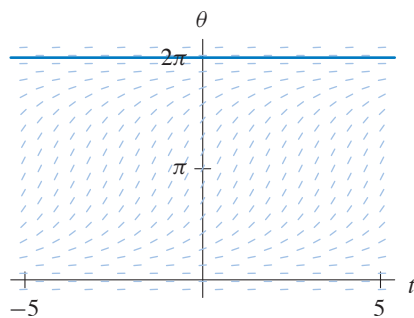

$$I_3 = 0.1$$

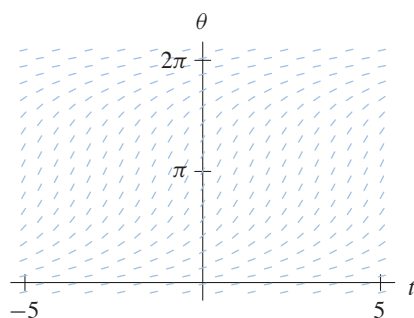

(b) For $I_1 = -0.1$, the equilibrium values satisfy the equation

$$1 - \cos \theta + (1 + \cos \theta)(-0.1) = 0.$$

We have

$$0.9 - 1.1 \cos \theta = 0$$

$$\cos \theta = \frac{0.9}{1.1}$$

$$\theta \approx \pm 0.613.$$

Therefore, the equilibrium values are $\theta \approx 2\pi n \pm 0.613$ radians, where n is any integer. There are two equilibrium solutions with values $\theta \approx 0.613$ and $\theta \approx 5.670$ between 0 and 2π .

For $I_2 = 0.0$, similar calculations yield equilibrium values at even multiples of 2π , and for $I_3 = 0.1$, there are no equilibrium values.

- (c) For $I_1 = -0.1$, the graphs of the equilibrium solutions divide the $t\theta$ -plane into horizontal strips in which the signs of the slopes do not change. For example, if $0.613 < \theta < 5.670$ (approximately), then the slopes are positive. If $5.670 < \theta < 6.896$ (approximately), then the slopes are negative. Therefore, any solution $\theta(t)$ with an initial condition θ_0 that is between 0.613 and 6.896 (approximately) satisfies the limit $\theta(t) \rightarrow 5.670$ (approximately) as $t \rightarrow \infty$. Moreover, any solution $\theta(t)$ with an initial condition θ_0 that is between -0.613 and 5.670 (approximately) satisfies the limit $\theta(t) \rightarrow 0.613$ (approximately) as $t \rightarrow -\infty$.

For $I_2 = 0.0$, the graphs of the equilibrium solutions also divide the $t\theta$ -plane into horizontal strips in which the signs of the slopes do not change. However, in this case, the slopes are always positive (or zero in the case of the equilibrium solutions). Therefore, for example, any solution $\theta(t)$ with an initial condition θ_0 that is between 0 and 2π satisfies the limits $\theta(t) \rightarrow 2\pi$ as $t \rightarrow \infty$ and $\theta(t) \rightarrow 0$ as $t \rightarrow -\infty$.

Lastly, if $I_3 = 0.1$, all of the slopes are positive, so all solutions are increasing for all t . The fact that $\theta(t) \rightarrow \infty$ as $t \rightarrow \infty$ requires an analytic estimate in addition to a qualitative analysis.

20. Separating variables, we have

$$\int \frac{dv_c}{v_c} = \int -\frac{1}{RC} dt$$

$$\ln |v_c| = -\frac{t}{RC} + c_1$$

$$|v_c| = c_2 e^{-t/RC}$$

where $c_2 = e^{c_1}$. We can eliminate the absolute value signs by allowing c_2 to be positive or negative. If we let $v_c(0) = c_2 e^0 = v_0$, then we obtain $c_2 = v_0$. Therefore $v_c(t) = v_0 e^{-t/RC}$ where $v_0 = v_c(0)$.

To check that this function is a solution, we calculate the left-hand side of the equation

$$\frac{dv_c}{dt} = \frac{d}{dt} v_0 e^{-t/RC} = -\frac{v_0}{RC} e^{-t/RC}.$$

The result agrees with the right-hand side because

$$-\frac{v_c}{RC} = -\frac{v_0 e^{-t/RC}}{RC} = -\frac{v_0}{RC} e^{-t/RC}.$$

21. Separating variables, we obtain

$$\int \frac{dv_c}{K - v_c} = \int \frac{dt}{RC}.$$

Integrating both sides, we have

$$-\ln |K - v_c| = \frac{t}{RC} + c_1,$$

where c_1 is a constant. Thus,

$$|K - v_c| = c_2 e^{-t/RC}$$

where $c_2 = e^{-c_1}$. We can eliminate the absolute values by allowing c_2 to assume either positive or negative values. Therefore, we obtain the general solution

$$v_c(t) = K + c e^{-t/RC}$$

where c can be any constant.

To check that $v_c(t)$ is a solution, we calculate the left-hand side of the equation

$$\frac{dv_c}{dt} = -\frac{c}{RC} e^{-t/RC},$$

and the right-hand side of the equation

$$\frac{K - v_c}{RC} = \frac{K - (K + c e^{-t/RC})}{RC} = -\frac{c}{RC} e^{-t/RC}.$$

Since they agree, $v_c(t)$ is a solution.

22. For $t < 3$, the differential equation is

$$\frac{dv_c}{dt} = \frac{3 - v_c}{(0.5)(1.0)} = 6 - 2v_c, \quad v_c(0) = 6.$$

Using the general solution from Exercise 21, where $K = 3$, $R = 0.5$, $C = 1.0$, and $v_c(0) = v_0 = 6$, we have

$$\begin{aligned} v_c(t) &= K + (v_0 - K)e^{-t/RC} \\ &= 3 + 3e^{-2t} \end{aligned}$$

for $t < 3$. To check that $v_c(t)$ is a solution, we calculate

$$\frac{dv_c}{dt} = -6e^{-2t}$$

as well as

$$6 - 2v_c = 6 - 2(3 + 3e^{-2t}) = -6e^{-2t}.$$

Since they agree, $v_c(t)$ is a solution.

To determine the solution for $t > 3$, we need to calculate $v_c(3)$. We get

$$v_c(3) = 3 + 3e^{(-2)(3)} = 3 + 3e^{-6}.$$

Therefore, the differential equation corresponding to $t > 3$ is

$$\frac{dv_c}{dt} = \frac{-v_c}{(0.5)(1.0)} = -2v_c, \quad v_c(3) = 3 + 3e^{-6}.$$

The solution for $t > 3$ is $v_c(t) = ke^{-2t}$. Evaluating at $t = 3$, we get

$$ke^{-6} = 3 + 3e^{-6}$$

$$k = 3e^6 + 3.$$

So $v_c(t) = (3e^6 + 3)e^{-2t}$. To check that $v_c(t)$ is a solution, we calculate

$$\frac{dv_c}{dt} = \frac{d}{dt}(3e^6 + 3)e^{-2t} = -2(3e^6 + 3)e^{-2t}$$

as well as

$$-2v_c = -2(3e^6 + 3)e^{-2t}.$$

Since they agree, $v_c(t)$ is a solution.

EXERCISES FOR SECTION 1.4

1.

Table 1.1
Results of Euler's method

k	t_k	y_k	m_k
0	0	3	7
1	0.5	6.5	14
2	1.0	13.5	28
3	1.5	27.5	56
4	2.0	55.5	

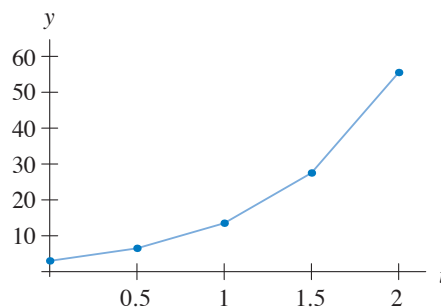

2.

Table 1.2
Results of Euler's method (y_k
rounded to two decimal places)

k	t_k	y_k	m_k
0	0	1	-1
1	0.25	0.75	-0.3125
2	0.5	0.67	0.0485
3	0.75	0.68	0.282
4	1.0	0.75	

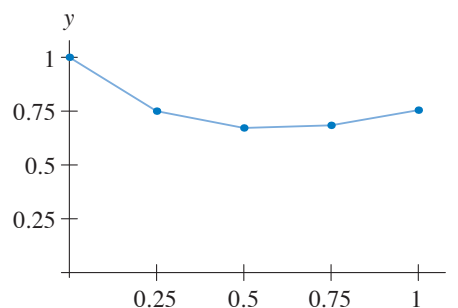

3.

Table 1.3
Results of Euler's method (shown rounded to two decimal places)

k	t_k	y_k	m_k
0	0	0.5	0.25
1	0.25	0.56	-0.68
2	0.50	0.39	-1.85
3	0.75	-0.07	-2.99
4	1.00	-0.82	-3.33
5	1.25	-1.65	-2.27
6	1.50	-2.22	-1.07
7	1.75	-2.49	-0.81
8	2.00	-2.69	

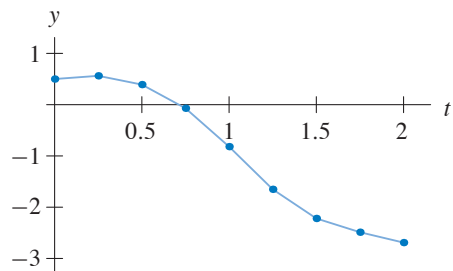

4.

Table 1.4
Results of Euler's method (to two decimal places)

k	t_k	y_k	m_k
0	0	1	0.84
1	0.5	1.42	0.99
2	1.0	1.91	0.94
3	1.5	2.38	0.68
4	2.0	2.73	0.40
5	2.5	2.93	0.21
6	3.0	3.03	

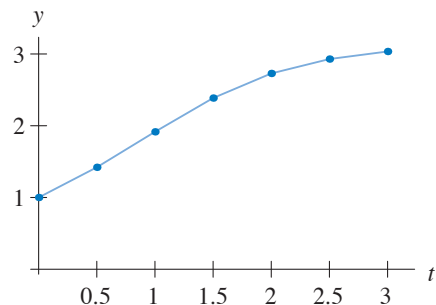

5.

Table 1.5
Results of Euler's method

k	t_k	w_k	m_k
0	0	4	-5
1	1	-1	0
2	2	-1	0
3	3	-1	0
4	4	-1	0
5	5	-1	

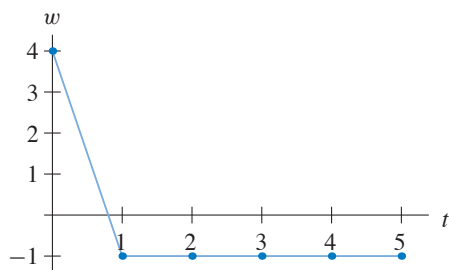

6.

Table 1.6
Results of Euler's method (shown rounded to two decimal places)

k	t_k	w_k	m_k
0	0	0	3
1	0.5	1.5	3.75
2	1.0	3.38	-1.64
3	1.5	2.55	1.58
4	2.0	3.35	-1.50
5	2.5	2.59	1.46
6	3.0	3.32	-1.40
7	3.5	2.62	1.36
8	4.0	3.31	-1.31
9	4.5	2.65	1.28
10	5.0	3.29	

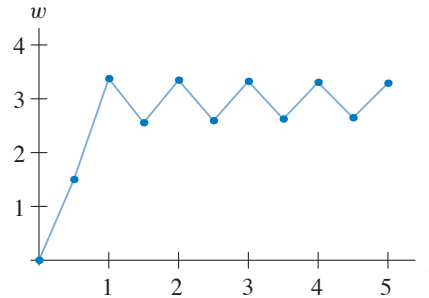

7.

Table 1.7
Results of Euler's method (shown rounded to two decimal places)

k	t_k	y_k	m_k
0	0	2	2.72
1	0.5	3.36	1.81
2	1.0	4.27	1.60
3	1.5	5.06	1.48
4	2.0	5.81	

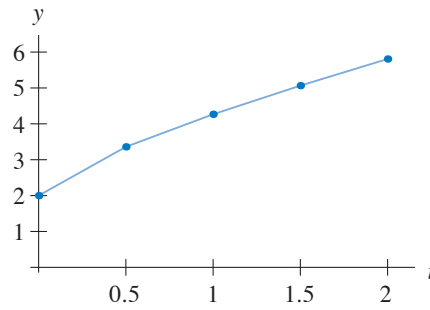

8.

Table 1.8
Results of Euler's method (shown rounded to two decimal places)

k	t_k	y_k	m_k
0	1.0	2	2.72
1	1.5	3.36	1.81
2	2.0	4.27	1.60
3	2.5	5.06	1.48
4	3.0	5.81	

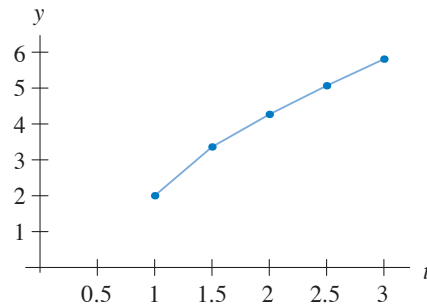

9.

Table 1.9
Results of Euler's method (shown rounded to three decimal places)

k	t_k	y_k	m_k
0	0.0	0.2	0.032
1	0.1	0.203	0.033
2	0.2	0.206	0.034
3	0.3	0.210	0.035
\vdots	\vdots	\vdots	\vdots
99	9.9	0.990	0.010
100	10.0	0.991	

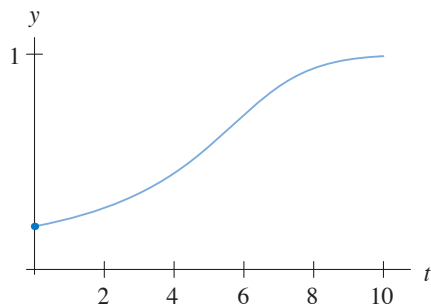

10.

Table 1.10
Results of Euler's method with Δt negative (shown rounded to three decimal places)

k	t_k	y_k	m_k
0	0	-0.5	-0.25
1	-0.1	-0.475	-0.204
2	-0.2	-0.455	-0.147
3	-0.3	-0.440	-0.080
\vdots	\vdots	\vdots	\vdots
19	-1.9	-1.160	0.488
20	-2.0	-1.209	0.467

Table 1.11
Results of Euler's method with Δt positive (shown rounded to three decimal places)

k	t_k	y_k	m_k
0	0	-0.5	-0.25
1	0.1	-0.525	-0.279
2	0.2	-0.553	-0.298
3	0.3	-0.583	-0.306
\vdots	\vdots	\vdots	\vdots
19	1.9	0.898	5.058
20	2.0	1.404	9.532

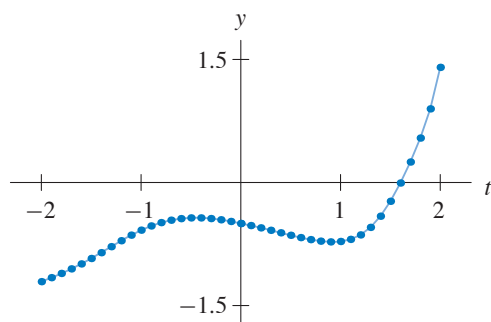

11. As the solution approaches the equilibrium solution corresponding to $w = 3$, its slope decreases. We do not expect the solution to “jump over” an equilibrium solution (see the Existence and Uniqueness Theorem in Section 1.5).

12. According to the formula derived in part (b) of Exercise 12 of Section 1.1, the terminal velocity (v_t) of the freefalling skydiver is

$$v_t = \sqrt{\frac{mg}{k}} = \sqrt{\frac{(54)(9.8)}{0.18}} = \sqrt{2940} \approx 54.22 \text{ m/s.}$$

Therefore, 95% of her terminal velocity is $0.95v_t = 0.95\sqrt{2940} \approx 51.51$ m/s. At the moment she jumps from the plane, $v(0) = 0$. We choose $\Delta t = 0.01$ to obtain a good approximation of when the skydiver reaches 95% of her terminal velocity. Using Euler's method with $\Delta t = 0.01$, we see that the skydiver reaches 95% of her terminal velocity when $t \approx 10.12$ seconds.

Table 1.12
Results of Euler's method (shown rounded to three decimal places)

k	t_k	v_k	m_k
0	0.0	0.0	9.8
1	0.01	0.098	9.800
2	0.02	0.196	9.800
\vdots	\vdots	\vdots	\vdots
1011	10.11	51.498	0.960
1012	10.12	51.508	0.956
\vdots	\vdots	\vdots	\vdots

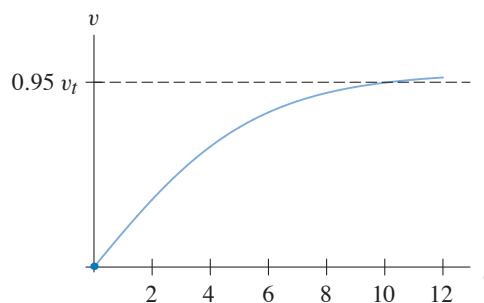

13. Because the differential equation is autonomous, the computation that determines y_{k+1} from y_k depends only on y_k and Δt and not on the actual value of t_k . Hence the approximate y -values that are obtained in both exercises are the same. It is useful to think about this fact in terms of the slope field of an autonomous equation.
14. Euler's method is not accurate in either case because the step size is too large. In Exercise 5, the approximate solution "jumps onto" an equilibrium solution. In Exercise 6, the approximate solution "crisscrosses" a different equilibrium solution. Approximate solutions generated with smaller values of Δt indicate that the actual solutions do not exhibit this behavior (see the Existence and Uniqueness Theorem of Section 1.5).

15.

Table 1.13
Results of Euler's method with $\Delta t = 1.0$ (shown to two decimal places)

k	t_k	y_k	m_k
0	0	1	1
1	1	2	1.41
2	2	3.41	1.85
3	3	5.26	2.29
4	4	7.56	

Table 1.14

Results of Euler's method with $\Delta t = 0.5$ (shown to two decimal places)

k	t_k	y_k	m_k	k	t_k	y_k	m_k
0	0	1	1	5	2.5	4.64	2.15
1	0.5	1.5	1.22	6	3.0	5.72	2.39
2	1.0	2.11	1.45	7	3.5	6.91	2.63
3	1.5	2.84	1.68	8	4.0	8.23	
4	2.0	3.68	1.92				

Table 1.15

Results of Euler's method with $\Delta t = 0.25$ (shown to two decimal places)

k	t_k	y_k	m_k	k	t_k	y_k	m_k
0	0	1	1	9	2.25	4.32	2.08
1	0.25	1.25	1.12	10	2.50	4.84	2.20
2	0.50	1.53	1.24	11	2.75	5.39	2.32
3	0.75	1.84	1.36	12	3.0	5.97	2.44
4	1.0	2.18	1.48	13	3.25	6.58	2.56
5	1.25	2.55	1.60	14	3.50	7.23	2.69
6	1.50	2.94	1.72	15	3.75	7.90	2.81
7	1.75	3.37	1.84	16	4.0	8.60	
8	2.0	3.83	1.96				

The slopes in the slope field are positive and increasing. Hence, the graphs of all solutions are concave up. Since Euler's method uses line segments to approximate the graph of the actual solution, the approximate solutions will always be less than the actual solution. This error decreases as the step size decreases.

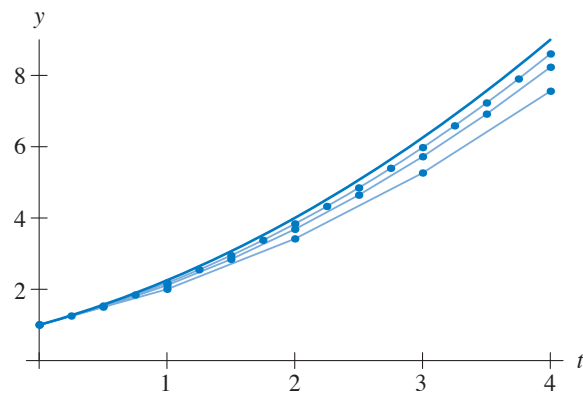

16.

Table 1.16
Results of Euler's method with $\Delta t = 1.0$ (shown to two decimal places)

k	t_k	y_k	m_k
0	0	1	1
1	1	2	0
2	2	2	0
3	3	2	0
4	4	2	

Table 1.17
Results of Euler's method with $\Delta t = 0.5$ (shown to two decimal places)

k	t_k	y_k	m_k
0	0	1	1
1	0.5	1.5	0.5
2	1.0	1.75	0.26
3	1.5	1.88	0.12
4	2.0	1.94	0.06
5	2.5	1.97	0.02
6	3.0	1.98	0.02
7	3.5	1.99	0.02
8	4.0	2.0	

Table 1.18
Results of Euler's method with $\Delta t = 0.25$ (shown to two decimal places)

k	t_k	y_k	m_k	k	t_k	y_k	m_k
0	0	1	1	9	2.25	1.92	0.08
1	0.25	1.25	0.76	10	2.50	1.94	0.06
2	0.50	1.44	0.56	11	2.75	1.96	0.04
3	0.75	1.58	0.40	12	3.0	1.97	0.03
4	1.0	1.68	0.32	13	3.25	1.98	0.02
5	1.25	1.76	0.24	14	3.50	1.98	0.02
6	1.50	1.82	0.18	15	3.75	1.99	0.01
7	1.75	1.87	0.13	16	4.0	1.99	
8	2.0	1.90	0.10				

From the differential equation, we see that dy/dt is positive and decreasing as long as $y(0) = 1$ and $y(t) < 2$ for $t > 0$. Therefore, $y(t)$ is increasing, and its graph is concave down. Since Euler's method uses line segments to approximate the graph of the actual solution, the approximate solutions will always be greater than the actual solution. This error decreases as the step size decreases.

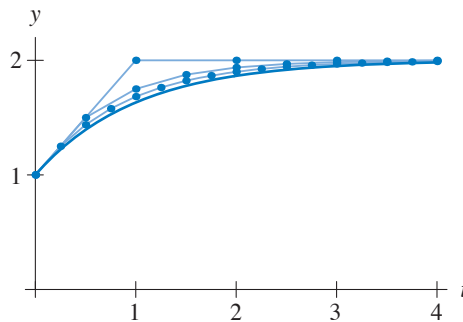

17. Assuming that $I(t) = 0.1$, the differential equation simplifies to

$$\frac{d\theta}{dt} = 0.9 - 1.1 \cos \theta.$$

Using Euler's method with $\Delta t = 0.1$, we obtain the results in the following table.

Table 1.19
Results of Euler's method (shown rounded to three decimal places)

k	t_k	y_k	m_k	k	t_k	y_k	m_k
0	0.0	1.0	0.306	23	2.3	3.376	1.970
1	0.1	1.031	0.334	24	2.4	3.573	1.899
2	0.2	1.064	0.366	25	2.5	3.763	1.794
\vdots	\vdots	\vdots	\vdots	\vdots	\vdots	\vdots	\vdots
21	2.1	2.978	1.985	49	4.9	5.452	0.159
22	2.2	3.176	1.999	50	5.0	5.467	

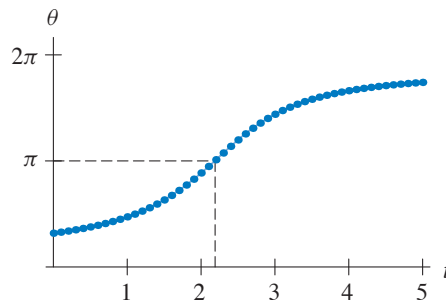

The graph of the results of Euler's method.

A neuron spikes when θ is equal to an odd multiple of π . Therefore, we need to determine when $\theta(t) = \pi$. From the results of Euler's method, we see that the neuron spikes when $t \approx 2.15$.

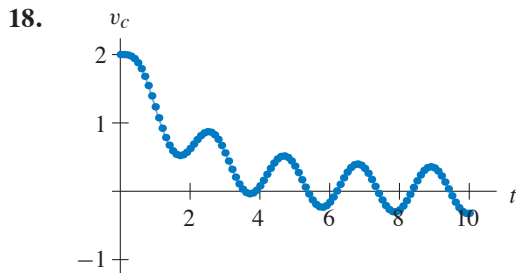

Graph of approximate solution obtained using Euler's method with $\Delta t = 0.1$.

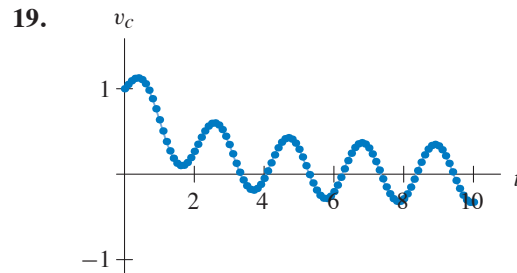

Graph of approximate solution obtained using Euler's method with $\Delta t = 0.1$.

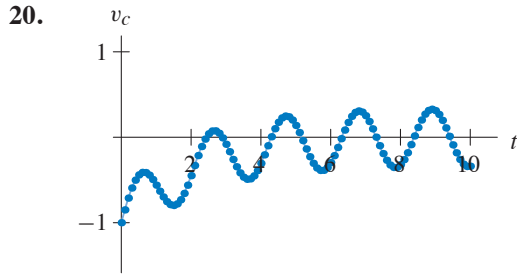

Graph of approximate solution obtained using Euler's method with $\Delta t = 0.1$.

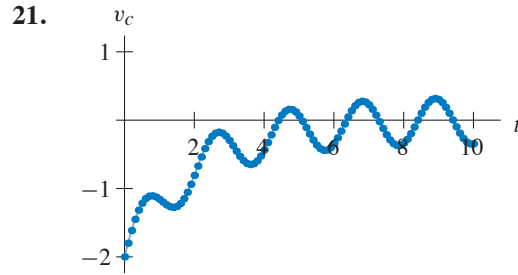

Graph of approximate solution obtained using Euler's method with $\Delta t = 0.1$.

EXERCISES FOR SECTION 1.5

1. Since the constant function $y_1(t) = 3$ for all t is a solution, then the graph of any other solution $y(t)$ with $y(0) < 3$ cannot cross the line $y = 3$ by the Uniqueness Theorem. So $y(t) < 3$ for all t in the domain of $y(t)$.
2. Since $y(0) = 1$ is between the equilibrium solutions $y_2(t) = 0$ and $y_3(t) = 2$, we must have $0 < y(t) < 2$ for all t because the Uniqueness Theorem implies that graphs of solutions cannot cross (or even touch in this case).
3. Because $y_2(0) < y(0) < y_1(0)$, we know that

$$-t^2 = y_2(t) < y(t) < y_1(t) = t + 2$$

for all t . This restricts how large positive or negative $y(t)$ can be for a given value of t (that is, between $-t^2$ and $t + 2$). As $t \rightarrow -\infty$, $y(t) \rightarrow -\infty$ between $-t^2$ and $t + 2$ ($y(t) \rightarrow -\infty$ as $t \rightarrow -\infty$ at least linearly, but no faster than quadratically).

4. Because $y_1(0) < y(0) < y_2(0)$, the solution $y(t)$ must satisfy $y_1(t) < y(t) < y_2(t)$ for all t by the Uniqueness Theorem. Hence $-1 < y(t) < 1 + t^2$ for all t .
5. The Existence Theorem implies that a solution with this initial condition exists, at least for a small t -interval about $t = 0$. This differential equation has equilibrium solutions $y_1(t) = 0$, $y_2(t) = 1$, and $y_3(t) = 3$ for all t . Since $y(0) = 4$, the Uniqueness Theorem implies that $y(t) > 3$ for all t in the domain of $y(t)$. Also, $dy/dt > 0$ for all $y > 3$, so the solution $y(t)$ is increasing for all t in its domain. Finally, $y(t) \rightarrow 3$ as $t \rightarrow -\infty$.
6. Note that $dy/dt = 0$ if $y = 0$. Hence, $y_1(t) = 0$ for all t is an equilibrium solution. By the Uniqueness Theorem, this is the only solution that is 0 at $t = 0$. Therefore, $y(t) = 0$ for all t .
7. The Existence Theorem implies that a solution with this initial condition exists, at least for a small t -interval about $t = 0$. Because $1 < y(0) < 3$ and $y_1(t) = 1$ and $y_2(t) = 3$ are equilibrium solutions

of the differential equation, we know that the solution exists for all t and that $1 < y(t) < 3$ for all t by the Uniqueness Theorem. Also, $dy/dt < 0$ for $1 < y < 3$, so dy/dt is always negative for this solution. Hence, $y(t) \rightarrow 1$ as $t \rightarrow \infty$, and $y(t) \rightarrow 3$ as $t \rightarrow -\infty$.

8. The Existence Theorem implies that a solution with this initial condition exists, at least for a small t -interval about $t = 0$. Note that $y(0) < 0$. Since $y_1(t) = 0$ is an equilibrium solution, the Uniqueness Theorem implies that $y(t) < 0$ for all t . Also, $dy/dt < 0$ if $y < 0$, so $y(t)$ is decreasing for all t , and $y(t) \rightarrow -\infty$ as t increases. As $t \rightarrow -\infty$, $y(t) \rightarrow 0$.

9. (a) To check that $y_1(t) = t^2$ is a solution, we compute

$$\frac{dy_1}{dt} = 2t$$

and

$$\begin{aligned} -y_1^2 + y_1 + 2y_1t^2 + 2t - t^2 - t^4 &= -(t^2)^2 + (t^2) + 2(t^2)t^2 + 2t - t^2 - t^4 \\ &= 2t. \end{aligned}$$

To check that $y_2(t) = t^2 + 1$ is a solution, we compute

$$\frac{dy_2}{dt} = 2t$$

and

$$\begin{aligned} -y_2^2 + y_2 + 2y_2t^2 + 2t - t^2 - t^4 &= -(t^2 + 1)^2 + (t^2 + 1) + 2(t^2 + 1)t^2 \\ &\quad + 2t - t^2 - t^4 \\ &= 2t. \end{aligned}$$

- (b) The initial values of the two solutions are $y_1(0) = 0$ and $y_2(0) = 1$. Thus if $y(t)$ is a solution and $y_1(0) = 0 < y(0) < 1 = y_2(0)$, then we can apply the Uniqueness Theorem to obtain

$$y_1(t) = t^2 < y(t) < t^2 + 1 = y_2(t)$$

for all t . Note that since the differential equation satisfies the hypothesis of the Existence and Uniqueness Theorem over the entire ty -plane, we can continue to extend the solution as long as it does not escape to $\pm\infty$ in finite time. Since it is bounded above and below by solutions that exist for all time, $y(t)$ is defined for all time also.

(c)

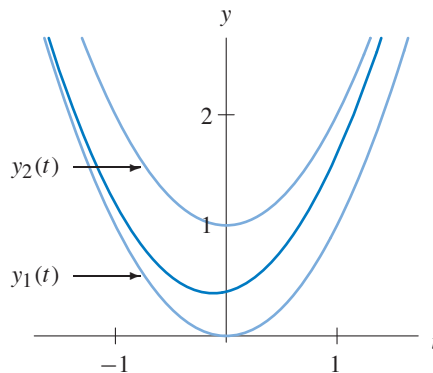

10. (a) If $y(t) = 0$ for all t , then $dy/dt = 0$ and $2\sqrt{|y(t)|} = 0$ for all t . Hence, the function that is constantly zero satisfies the differential equation.
- (b) First, consider the case where $y > 0$. The differential equation reduces to $dy/dt = 2\sqrt{y}$. If we separate variables and integrate, we obtain

$$\sqrt{y} = t - c,$$

where c is any constant. The graph of this equation is the half of the parabola $y = (t - c)^2$ where $t \geq c$.

Next, consider the case where $y < 0$. The differential equation reduces to $dy/dt = 2\sqrt{-y}$. If we separate variables and integrate, we obtain

$$\sqrt{-y} = d - t,$$

where d is any constant. The graph of this equation is the half of the parabola $y = -(d - t)^2$ where $t \leq d$.

To obtain all solutions, we observe that any choice of constants c and d where $c \geq d$ leads to a solution of the form

$$y(t) = \begin{cases} -(d - t)^2, & \text{if } t \leq d; \\ 0, & \text{if } d \leq t \leq c; \\ (t - c)^2, & \text{if } t \geq c. \end{cases}$$

(See the following figure for the case where $d = -2$ and $c = 1$.)

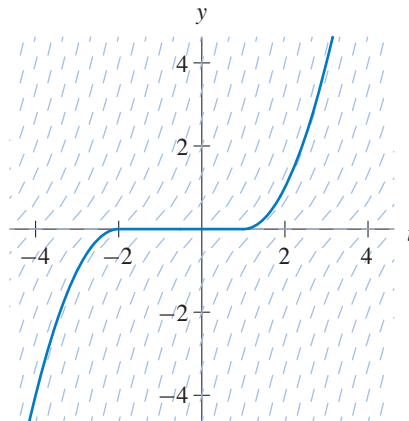

- (c) The partial derivative $\partial f/\partial y$ of $f(t, y) = \sqrt{|y|}$ does not exist along the t -axis.
- (d) If $y_0 = 0$, `HPGSolver` plots the equilibrium solution that is constantly zero. If $y_0 \neq 0$, it plots a solution whose graph crosses the t -axis. This is a solution where $c = d$ in the formula given above.
11. The key observation is that the differential equation is not defined when $t = 0$.
- (a) Note that $dy_1/dt = 0$ and $y_1/t^2 = 0$, so $y_1(t)$ is a solution.

(b) Separating variables, we have

$$\int \frac{dy}{y} = \int \frac{dt}{t^2}.$$

Solving for y we obtain $y(t) = ce^{-1/t}$, where c is any constant. Thus, for any real number c , define the function $y_c(t)$ by

$$y_c(t) = \begin{cases} 0 & \text{for } t \leq 0; \\ ce^{-1/t} & \text{for } t > 0. \end{cases}$$

For each c , $y_c(t)$ satisfies the differential equation for all $t \neq 0$.

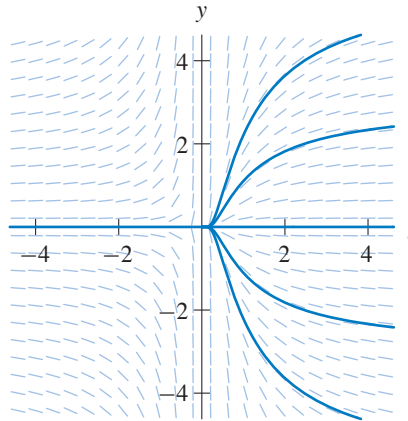

There are infinitely many solutions of the form $y_c(t)$ that agree with $y_1(t)$ for $t < 0$.

(c) Note that $f(t, y) = y/t^2$ is not defined at $t = 0$. Therefore, we *cannot* apply the Uniqueness Theorem for the initial condition $y(0) = 0$. The “solution” $y_c(t)$ given in part (b) actually represents two solutions, one for $t < 0$ and one for $t > 0$.

12. (a) Note that

$$\frac{dy_1}{dt} = \frac{d}{dt} \left(\frac{1}{t-1} \right) = -\frac{1}{(t-1)^2} = -(y_1(t))^2$$

and

$$\frac{dy_2}{dt} = \frac{d}{dt} \left(\frac{1}{t-2} \right) = -\frac{1}{(t-2)^2} = -(y_2(t))^2,$$

so both $y_1(t)$ and $y_2(t)$ are solutions.

(b) Note that $y_1(0) = -1$ and $y_2(0) = -1/2$. If $y(t)$ is another solution whose initial condition satisfies $-1 < y(0) < -1/2$, then $y_1(t) < y(t) < y_2(t)$ for all t by the Uniqueness Theorem. Also, since $dy/dt < 0$, $y(t)$ is decreasing for all t in its domain. Therefore, $y(t) \rightarrow 0$ as $t \rightarrow -\infty$, and the graph of $y(t)$ has a vertical asymptote between $t = 1$ and $t = 2$.

13. (a) The equation is separable. We separate the variables and compute

$$\int y^{-3} dy = \int dt.$$

Solving for y , we obtain

$$y(t) = \frac{1}{\sqrt{c-2t}}$$

for any constant c . To find the desired solution, we use the initial condition $y(0) = 1$ and obtain $c = 1$. So the solution to the initial-value problem is

$$y(t) = \frac{1}{\sqrt{1-2t}}.$$

- (b) This solution is defined when $-2t + 1 > 0$, which is equivalent to $t < 1/2$.
 (c) As $t \rightarrow 1/2^-$, the denominator of $y(t)$ becomes a small positive number, so $y(t) \rightarrow \infty$. We only consider $t \rightarrow 1/2^-$ because the solution is defined only for $t < 1/2$. (The other “branch” of the function is also a solution, but the solution that includes $t = 0$ in its domain is not defined for $t \geq 1/2$.) As $t \rightarrow -\infty$, $y(t) \rightarrow 0$.

14. (a) The equation is separable, so we obtain

$$\int (y+1) dy = \int \frac{dt}{t-2}.$$

Solving for y with help from the quadratic formula yields the general solution

$$y(t) = -1 \pm \sqrt{1 + \ln(c(t-2)^2)}$$

where c is a constant. Substituting the initial condition $y(0) = 0$ and solving for c , we have

$$0 = -1 \pm \sqrt{1 + \ln(4c)},$$

and thus $c = 1/4$. The desired solution is therefore

$$y(t) = -1 + \sqrt{1 + \ln((1-t/2)^2)}$$

- (b) The solution is defined only when $1 + \ln((1-t/2)^2) \geq 0$, that is, when $|t-2| \geq 2/\sqrt{e}$. Therefore, the domain of the solution is

$$t \leq 2(1 - 1/\sqrt{e}).$$

- (c) As $t \rightarrow 2(1 - 1/\sqrt{e})$, then $1 + \ln((1-t/2)^2) \rightarrow 0$. Thus

$$\lim_{t \rightarrow 2(1-1/\sqrt{e})} y(t) = -1.$$

Note that the differential equation is not defined at $y = -1$. Also, note that

$$\lim_{t \rightarrow -\infty} y(t) = \infty.$$

15. (a) The equation is separable. We separate, integrate

$$\int (y + 2)^2 dy = \int dt,$$

and solve for y to obtain the general solution

$$y(t) = (3t + c)^{1/3} - 2,$$

where c is any constant. To obtain the desired solution, we use the initial condition $y(0) = 1$ and solve

$$1 = (3 \cdot 0 + c)^{1/3} - 2$$

for c to obtain $c = 27$. So the solution to the given initial-value problem is

$$y(t) = (3t + 27)^{1/3} - 2.$$

- (b) This function is defined for all t . However, $y(-9) = -2$, and the differential equation is not defined at $y = -2$. Strictly speaking, the solution exists only for $t > -9$.
 (c) As $t \rightarrow \infty$, $y(t) \rightarrow \infty$. As $t \rightarrow -9^+$, $y(t) \rightarrow -2$.

16. (a) The equation is separable. Separating variables we obtain

$$\int (y - 2) dy = \int t dt.$$

Solving for y with help from the quadratic formula yields the general solution

$$y(t) = 2 \pm \sqrt{t^2 + c}.$$

To find c , we let $t = -1$ and $y = 0$, and we obtain $c = 3$. The desired solution is therefore $y(t) = 2 - \sqrt{t^2 + 3}$

- (b) Since $t^2 + 2$ is always positive and $y(t) < 2$ for all t , the solution $y(t)$ is defined for all real numbers.
 (c) As $t \rightarrow \pm\infty$, $t^2 + 3 \rightarrow \infty$. Therefore,

$$\lim_{t \rightarrow \pm\infty} y(t) = -\infty.$$

17. This exercise shows that solutions of autonomous equations cannot have local maximums or minimums. Hence they must be either constant or monotonically increasing or monotonically decreasing. A useful corollary is that a function $y(t)$ that oscillates cannot be the solution of an autonomous differential equation.

- (a) Note $dy_1/dt = 0$ at $t = t_0$ because $y_1(t)$ has a local maximum. Because $y_1(t)$ is a solution, we know that $dy_1/dt = f(y_1(t))$ for all t in the domain of $y_1(t)$. In particular,

$$0 = \left. \frac{dy_1}{dt} \right|_{t=t_0} = f(y_1(t_0)) = f(y_0),$$

so $f(y_0) = 0$.

- (b) This differential equation is autonomous, so the slope marks along any given horizontal line are parallel. Hence, the slope marks along the line $y = y_0$ must all have zero slope.
- (c) For all t ,

$$\frac{dy_2}{dt} = \frac{d(y_0)}{dt} = 0$$

because the derivative of a constant function is zero, and for all t

$$f(y_2(t)) = f(y_0) = 0.$$

So $y_2(t)$ is a solution.

- (d) By the Uniqueness Theorem, we know that two solutions that are in the same place at the same time are the same solution. We have $y_1(t_0) = y_0 = y_2(t_0)$. Moreover, $y_1(t)$ is assumed to be a solution, and we showed that $y_2(t)$ is a solution in parts (a) and (b) of this exercise. So $y_1(t) = y_2(t)$ for all t . In other words, $y_1(t) = y_0$ for all t .
- (e) Follow the same four steps as before. We still have $dy_1/dt = 0$ at $t = t_0$ because y_1 has a local minimum at $t = t_0$.
18. (a) Solving for r , we get

$$r = \left(\frac{3v}{4\pi}\right)^{1/3}$$

Consequently,

$$\begin{aligned} s(t) &= 4\pi \left(\frac{3v}{4\pi}\right)^{2/3} \\ &= cv(t)^{2/3}, \end{aligned}$$

where c is a constant. Since we are assuming that the rate of growth of $v(t)$ is proportional to its surface area $s(t)$, we have

$$\frac{dv}{dt} = kv^{2/3},$$

where k is a constant.

- (b) The partial derivative with respect to v of dv/dt does not exist at $v = 0$. Hence the Uniqueness Theorem tells us nothing about the uniqueness of solutions that involve $v = 0$. In fact, if we use the techniques described in the section related to the uniqueness of solutions for $dy/dt = 3y^{2/3}$, we can find infinitely many solutions with this initial condition.
- (c) Since it does not make sense to talk about rain drops with negative volume, we always have $v \geq 0$. Once $v > 0$, the evolution of the drop is completely determined by the differential equation.

What is the physical significance of a drop with $v = 0$? It is tempting to interpret the fact that solutions can have $v = 0$ for an arbitrary amount of time before beginning to grow as a statement that the rain drops can spontaneously begin to grow at any time. Since the model gives no information about when a solution with $v = 0$ starts to grow, it is not very useful for the understanding the initial formation of rain drops. The safest assertion is to say the model breaks down if $v = 0$.

EXERCISES FOR SECTION 1.6

1. The equilibrium points of $dy/dt = f(y)$ are the numbers y where $f(y) = 0$. For $f(y) = 3y(y - 2)$, the equilibrium points are $y = 0$ and $y = 2$. Since $f(y)$ is positive for $y < 0$, negative for $0 < y < 2$, and positive for $y > 2$, the equilibrium point $y = 0$ is a sink and the equilibrium point $y = 2$ is a source.

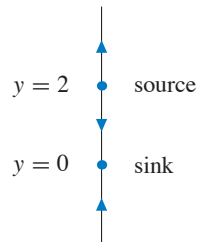

2. The equilibrium points of $dy/dt = f(y)$ are the numbers y where $f(y) = 0$. For $f(y) = y^2 - 4y - 12 = (y - 6)(y + 2)$, the equilibrium points are $y = -2$ and $y = 6$. Since $f(y)$ is positive for $y < -2$, negative for $-2 < y < 6$, and positive for $y > 6$, the equilibrium point $y = -2$ is a sink and the equilibrium point $y = 6$ is a source.

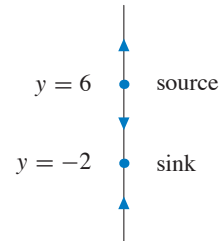

3. The equilibrium points of $dy/dt = f(y)$ are the numbers y where $f(y) = 0$. For $f(y) = \cos y$, the equilibrium points are $y = \pi/2 + n\pi$, where $n = 0, \pm 1, \pm 2, \dots$. Since $\cos y > 0$ for $-\pi/2 < y < \pi/2$ and $\cos y < 0$ for $\pi/2 < y < 3\pi/2$, we see that the equilibrium point at $y = \pi/2$ is a sink. Since the sign of $\cos y$ alternates between positive and negative in a period fashion, we see that the equilibrium points at $y = \pi/2 + 2n\pi$ are sinks and the equilibrium points at $y = 3\pi/2 + 2n\pi$ are sources.

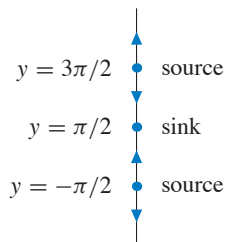

4. The equilibrium points of $dw/dt = f(w)$ are the numbers w where $f(w) = 0$. For $f(w) = w \cos w$, the equilibrium points are $w = 0$ and $w = \pi/2 + n\pi$, where $n = 0, \pm 1, \pm 2, \dots$. The sign of $w \cos w$ alternates positive and negative at successive zeros. It is negative for $-\pi/2 < w < 0$ and positive for $0 < w < \pi/2$. Therefore, $w = 0$ is a source, and the equilibrium points alternate back and forth between sources and sinks.

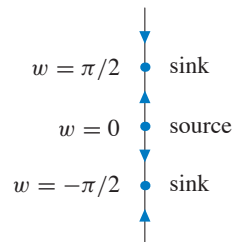

5. The equilibrium points of $dw/dt = f(w)$ are the numbers w where $f(w) = 0$. For $f(w) = (1 - w) \sin w$, the equilibrium points are $w = 1$ and $w = n\pi$, where $n = 0, \pm 1, \pm 2, \dots$. The sign of $(1 - w) \sin w$ alternates between positive and negative at successive zeros. It is negative for $-\pi < w < 0$ and positive for $0 < w < 1$. Therefore, $w = 0$ is a source, and the equilibrium points alternate between sinks and sources.

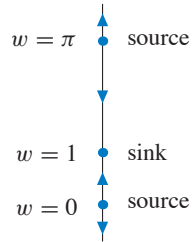

6. This equation has no equilibrium points, but the equation is not defined at $y = 2$. For $y > 2$, $dy/dt > 0$, so solutions increase. If $y < 2$, $dy/dt < 0$, so solutions decrease. The solutions approach the point $y = 2$ as time decreases and actually arrive there in finite time.

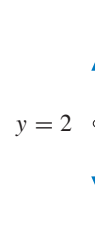

7. The derivative dv/dt is always negative, so there are no equilibrium points, and all solutions are decreasing.



8. The equilibrium points of $dw/dt = f(w)$ are the numbers w where $f(w) = 0$. For $f(w) = 3w^3 - 12w^2$, the equilibrium points are $w = 0$ and $w = 4$. Since $f(w) < 0$ for $w < 0$ and $0 < w < 4$, and $f(w) > 0$ for $w > 4$, the equilibrium point at $w = 0$ is a node and the equilibrium point at $w = 4$ is a source.

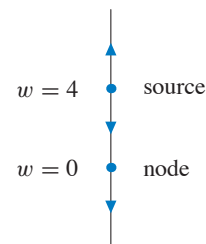

9. The equilibrium points of $dy/dt = f(y)$ are the numbers y where $f(y) = 0$. For $f(y) = 1 + \cos y$, the equilibrium points are $y = n\pi$, where $n = \pm 1, \pm 3, \dots$. Since $f(y)$ is non-negative for all values of y , all of the equilibrium points are nodes.

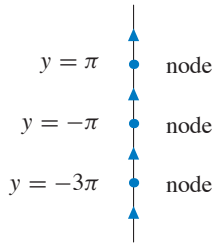

10. The equilibrium points of $dy/dt = f(y)$ are the numbers y where $f(y) = 0$. For $f(y) = \tan y$, the equilibrium points are $y = n\pi$ for $n = 0, \pm 1, \pm 2, \dots$. Since $\tan y$ changes from negative to positive at each of its zeros, all of these equilibria are sources.

The differential equation is not defined at $y = \pi/2 + n\pi$ for $n = 0, \pm 1, \pm 2, \dots$. Solutions increase or decrease toward one of these points as t increases and reach it in finite time.

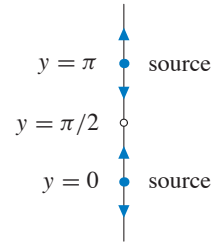

11. The equilibrium points of $dy/dt = f(y)$ are the numbers y where $f(y) = 0$. For $f(y) = y \ln |y|$, there are equilibrium points at $y = \pm 1$. In addition, although the function $f(y)$ is technically undefined at $y = 0$, the limit of $f(y)$ as $y \rightarrow 0$ is 0. Thus we can treat $y = 0$ as another equilibrium point. Since $f(y) < 0$ for $y < -1$ and $0 < y < 1$, and $f(y) > 0$ for $y > 1$ and $-1 < y < 0$, $y = -1$ is a source, $y = 0$ is a sink, and $y = 1$ is a source.

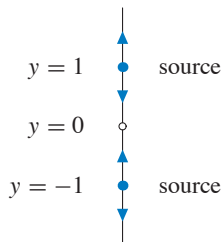

12. The equilibrium points of $dw/dt = f(w)$ are the numbers w where $f(w) = 0$. For $f(w) = (w^2 - 2) \arctan w$, there are equilibrium points at $w = \pm\sqrt{2}$ and $w = 0$. Since $f(w) > 0$ for $w > \sqrt{2}$ and $-\sqrt{2} < w < 0$, and $f(w) < 0$ for $w < -\sqrt{2}$ and $0 < w < \sqrt{2}$, the equilibrium points at $w = \pm\sqrt{2}$ are sources, and the equilibrium point at $w = 0$ is a sink.

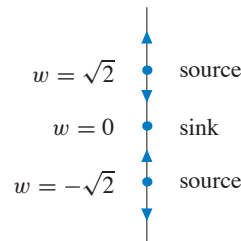

13.

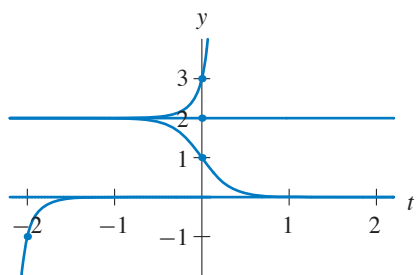

14.

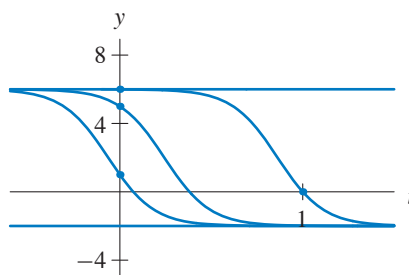

15.

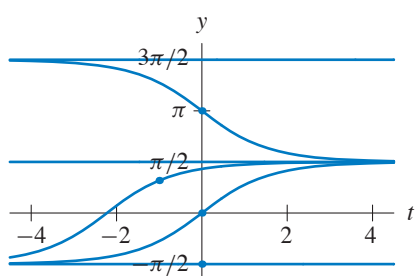

16.

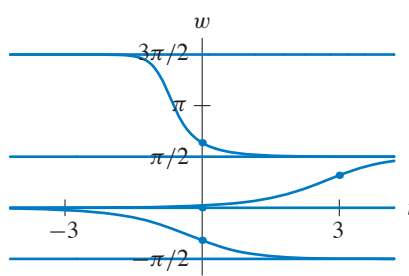

17.

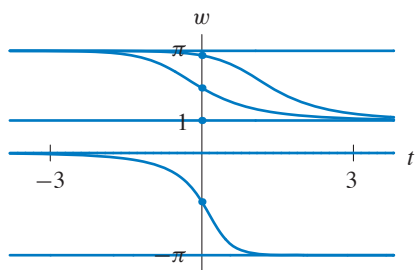

18.

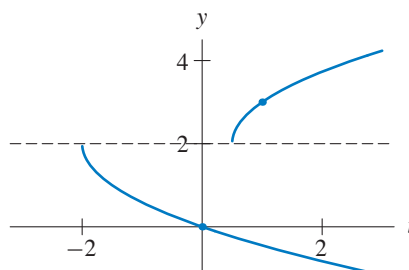

The equation is undefined at $y = 2$.

19.

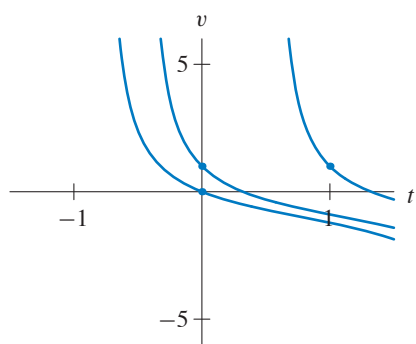

20.

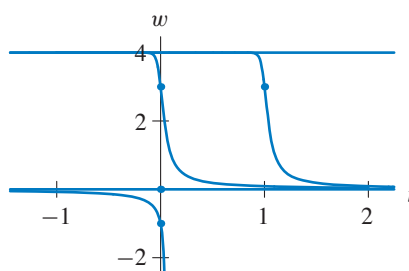

21.

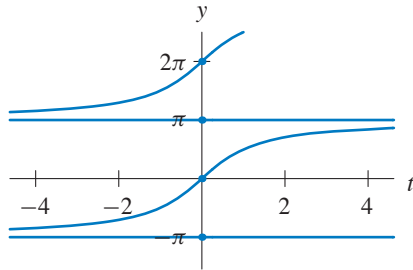

22. Because $y(0) = -1 < 2 - \sqrt{2}$, this solution increases toward $2 - \sqrt{2}$ as t increases and decreases as t decreases.
23. The initial value $y(0) = 2$ is between the equilibrium points $y = 2 - \sqrt{2}$ and $y = 2 + \sqrt{2}$. Also, $dy/dt < 0$ for $2 - \sqrt{2} < y < 2 + \sqrt{2}$. Hence the solution is decreasing and tends toward $y = 2 - \sqrt{2}$ as $t \rightarrow \infty$. It tends toward $y = 2 + \sqrt{2}$ as $t \rightarrow -\infty$.
24. The initial value $y(0) = -2$ is below both equilibrium points. Since $dy/dt > 0$ for $y < 2 - \sqrt{2}$, the solution is increasing for all t and tends to the equilibrium point $y = 2 - \sqrt{2}$ as $t \rightarrow \infty$. As t decreases, $y(t) \rightarrow -\infty$ in finite time. In fact, because $y(0) = -2 < -1$, this solution is always below the solution in Exercise 22.
25. The initial value $y(0) = -4$ is below both equilibrium points. Since $dy/dt > 0$ for $y < 2 - \sqrt{2}$, the solution is increasing for all t and tends to the equilibrium point $y = 2 - \sqrt{2}$ as $t \rightarrow \infty$. As t decreases, $y(t) \rightarrow -\infty$ in finite time.
26. The initial value $y(0) = 4$ is greater than the largest equilibrium point $2 + \sqrt{2}$, and $dy/dt > 0$ if $y > 2 + \sqrt{2}$. Hence, this solution increases without bound as t increases. (In fact, it blows up in finite time). As $t \rightarrow -\infty$, $y(t) \rightarrow 2 + \sqrt{2}$.
27. The initial value $y(3) = 1$ is between the equilibrium points $y = 2 - \sqrt{2}$ and $y = 2 + \sqrt{2}$. Also, $dy/dt < 0$ for $2 - \sqrt{2} < y < 2 + \sqrt{2}$. Hence the solution is decreasing and tends toward the smaller equilibrium point $y = 2 - \sqrt{2}$ as $t \rightarrow \infty$. It tends toward the larger equilibrium point $y = 2 + \sqrt{2}$ as $t \rightarrow -\infty$.
28. (a) Any solution that has an initial value between the equilibrium points at $y = -1$ and $y = 2$ must remain between these values for all t , so $-1 < y(t) < 2$ for all t .
- (b) The extra assumption implies that the solution is increasing for all t such that $-1 < y(t) < 2$. Again assuming that the Uniqueness Theorem applies, we conclude that $y(t) \rightarrow 2$ as $t \rightarrow \infty$ and $y(t) \rightarrow -1$ as $t \rightarrow -\infty$.
29. The function $f(y)$ has two zeros $\pm y_0$, where y_0 is some positive number. So the differential equation $dy/dt = f(y)$ has two equilibrium solutions, one for each zero. Also, $f(y) < 0$ if $-y_0 < y < y_0$ and $f(y) > 0$ if $y < -y_0$ or if $y > y_0$. Hence y_0 is a source and $-y_0$ is a sink.



30. The function $f(y)$ has two zeros, one positive and one negative. We denote them as y_1 and y_2 , where $y_1 < y_2$. So the differential equation $dy/dt = f(y)$ has two equilibrium solutions, one for each zero. Also, $f(y) > 0$ if $y_1 < y < y_2$ and $f(y) < 0$ if $y < y_1$ or if $y > y_2$. Hence y_1 is a source and y_2 is a sink.



31. The function $f(y)$ has three zeros. We denote them as y_1, y_2 , and y_3 , where $y_1 < 0 < y_2 < y_3$. So the differential equation $dy/dt = f(y)$ has three equilibrium solutions, one for each zero. Also, $f(y) > 0$ if $y < y_1$, $f(y) < 0$ if $y_1 < y < y_2$, and $f(y) > 0$ if $y_2 < y < y_3$ or if $y > y_3$. Hence y_1 is a sink, y_2 is a source, and y_3 is a node.



32. The function $f(y)$ has four zeros, which we denote y_1, \dots, y_4 where $y_1 < 0 < y_2 < y_3 < y_4$. So the differential equation $dy/dt = f(y)$ has four equilibrium solutions, one for each zero. Also, $f(y) > 0$ if $y < y_1$, if $y_2 < y < y_3$, or if $y_3 < y < y_4$; and $f(y) < 0$ if $y_1 < y < y_2$ or if $y > y_4$. Hence y_1 is a sink, y_2 is a source, y_3 is a node, and y_4 is a sink.



33. Since there are two equilibrium points, the graph of $f(y)$ must touch the y -axis at two distinct numbers y_1 and y_2 . Assume that $y_1 < y_2$. Since the arrows point up if $y < y_1$ and if $y > y_2$, we must have $f(y) > 0$ for $y < y_1$ and for $y > y_2$. Similarly, $f(y) < 0$ for $y_1 < y < y_2$.

The precise location of the equilibrium points is not given, and the direction of the arrows on the phase line is determined only by the sign (and not the magnitude) of $f(y)$. So the following graph is one of many possible answers.

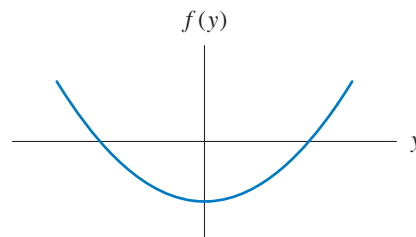

34. Since there are four equilibrium points, the graph of $f(y)$ must touch the y -axis at four distinct numbers y_1, y_2, y_3 , and y_4 . We assume that $y_1 < y_2 < y_3 < y_4$. Since the arrows point up only if $y_1 < y < y_2$ or if $y_2 < y < y_3$, we must have $f(y) > 0$ for $y_1 < y < y_2$ and for $y_2 < y < y_3$. Moreover, $f(y) < 0$ if $y < y_1$, if $y_3 < y < y_4$, or if $y > y_4$. Therefore, the graph of f crosses the y -axis at y_1 and y_3 , but it is tangent to the y -axis at y_2 and y_4 .

The precise location of the equilibrium points is not given, and the direction of the arrows on the phase line is determined only by the sign (and not the magnitude) of $f(y)$. So the following graph is one of many possible answers.

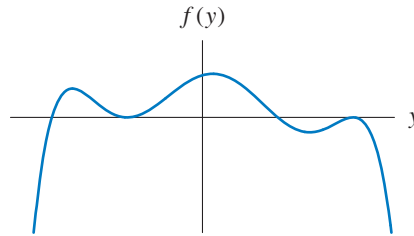

- 35.** Since there are three equilibrium points (one appearing to be at $y = 0$), the graph of $f(y)$ must touch the y -axis at three numbers y_1, y_2 , and y_3 . We assume that $y_1 < y_2 = 0 < y_3$. Since the arrows point down for $y < y_1$ and $y_2 < y < y_3$, $f(y) < 0$ for $y < y_1$ and for $y_2 < y < y_3$. Similarly, $f(y) > 0$ if $y_1 < y < y_2$ and if $y > y_3$.

The precise location of the equilibrium points is not given, and the direction of the arrows on the phase line is determined only by the sign (and not the magnitude) of $f(y)$. So the following graph is one of many possible answers.

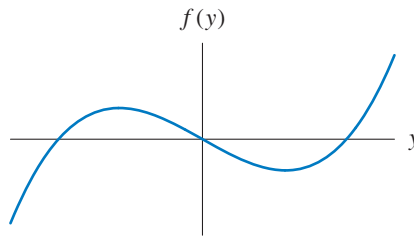

- 36.** Since there are three equilibrium points (one appearing to be at $y = 0$), the graph of $f(y)$ must touch the y -axis at three numbers y_1, y_2 , and y_3 . We assume that $y_1 < y_2 = 0 < y_3$. Since the arrows point up only for $y < y_1$, $f(y) > 0$ only if $y < y_1$. Otherwise, $f(y) \leq 0$.

The precise location of the equilibrium points is not given, and the direction of the arrows on the phase line is determined only by the sign (and not the magnitude) of $f(y)$. So the following graph is one of many possible answers.

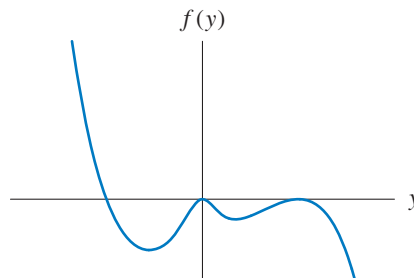

37. (a) This phase line has two equilibrium points, $y = 0$ and $y = 1$. Equations (ii), (iv), (vi), and (viii) have exactly these equilibria. There exists a node at $y = 0$. Only equations (iv) and (viii) have a node at $y = 0$. Moreover, for this phase line, $dy/dt < 0$ for $y > 1$. Only equation (viii) satisfies this property. Consequently, the phase line corresponds to equation (viii).
- (b) This phase line has two equilibrium points, $y = 0$ and $y = 1$. Equations (ii), (iv), (vi) and (viii) have exactly these equilibria. Moreover, for this phase line, $dy/dt > 0$ for $y > 1$. Only equations (iv) and (vi) satisfy this property. Lastly, $dy/dt > 0$ for $y < 0$. Only equation (vi) satisfies this property. Consequently, the phase line corresponds to equation (vi).
- (c) This phase line has an equilibrium point at $y = 3$. Only equations (i) and (v) have this equilibrium point. Moreover, this phase line has another equilibrium point at $y = 0$. Only equation (i) satisfies this property. Consequently, the phase line corresponds to equation (i).
- (d) This phase line has an equilibrium point at $y = 2$. Only equations (iii) and (vii) have this equilibrium point. Moreover, there exists a node at $y = 0$. Only equation (vii) satisfies this property. Consequently, the phase line corresponds to equation (vii).

38. (a) Because $f(y)$ is continuous we can use the Intermediate Value Theorem to say that there must be a zero of $f(y)$ between -10 and 10 . This value of y is an equilibrium point of the differential equation. In fact, $f(y)$ must cross from positive to negative, so if there is a single equilibrium point, it must be a sink (see part (b)).
- (b) We know that $f(y)$ must cross the y -axis between -10 and 10 . Moreover, it must cross from positive to negative because $f(-10)$ is positive and $f(10)$ is negative. Where $f(y)$ crosses the y -axis from positive to negative, we have a sink. If $y = 1$ is a source, then crosses the y -axis from negative to positive at $y = 1$. Hence, $f(y)$ must cross the y -axis from positive to negative at least once between $y = -10$ and $y = 1$ and at least once between $y = 1$ and $y = 10$. There must be at least one sink in each of these intervals. (We need the assumption that the number of equilibrium points is finite to prevent cases where $f(y) = 0$ along an entire interval.)

39. (a) In terms of the phase line with $P \geq 0$, there are three equilibrium points. If we assume that $f(P)$ is differentiable, then a decreasing population at $P = 100$ implies that $f(P) < 0$ for $P > 50$. An increasing population at $P = 25$ implies that $f(P) > 0$ for $10 < P < 50$. These assumptions leave two possible phase lines since the arrow between $P = 0$ and $P = 10$ is undetermined.

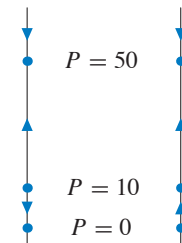

- (b) Given the observations in part (a), we see that there are two basic types of graphs that go with the assumptions. However, there are many graphs that correspond to each possibility. The following two graphs are representative.

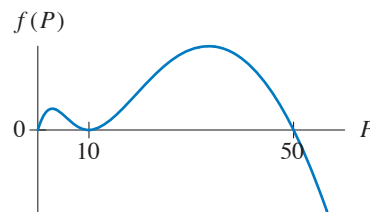
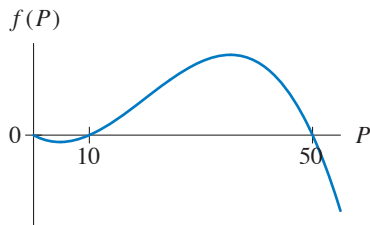

(c) The functions $f(P) = P(P - 10)(50 - P)$ and $f(P) = P(P - 10)^2(50 - P)$ respectively are two examples but there are many others.

40. (a) The equilibrium points of $d\theta/dt = f(\theta)$ are the numbers θ where $f(\theta) = 0$. For

$$f(\theta) = 1 - \cos \theta + (1 + \cos \theta) \left(-\frac{1}{3}\right) = \frac{2}{3}(1 - 2 \cos \theta),$$

the equilibrium points are $\theta = 2\pi n \pm \pi/3$, where $n = 0, \pm 1, \pm 2, \dots$

(b) The sign of $d\theta/dt$ alternates between positive and negative at successive equilibrium points. It is negative for $-\pi/3 < \theta < \pi/3$ and positive for $\pi/3 < \theta < 5\pi/3$. Therefore, $\pi/3 = 0$ is a source, and the equilibrium points alternate back and forth between sources and sinks.

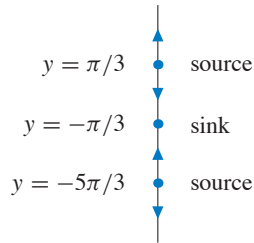

41. The equilibrium points occur at solutions of $dy/dt = y^2 + a = 0$. For $a > 0$, there are no equilibrium points. For $a = 0$, there is one equilibrium point, $y = 0$. For $a < 0$, there are two equilibrium points, $y = \pm\sqrt{-a}$.

To draw the phase lines, note that:

- If $a > 0$, $dy/dt = y^2 + a > 0$, so the solutions are always increasing.
- If $a = 0$, $dy/dt > 0$ unless $y = 0$. Thus, $y = 0$ is a node.
- For $a < 0$, $dy/dt < 0$ for $-\sqrt{-a} < y < \sqrt{-a}$, and $dy/dt > 0$ for $y < -\sqrt{-a}$ and for $y > \sqrt{-a}$.

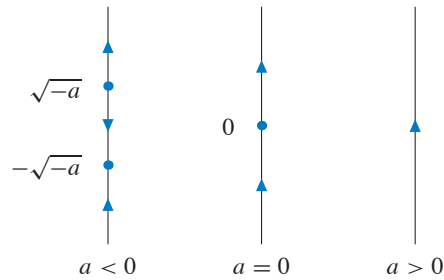

(a) The phase lines for $a < 0$ are qualitatively the same, and the phase lines for $a > 0$ are qualitatively the same.

(b) The phase line undergoes a qualitative change at $a = 0$.

42. The equilibrium points occur at solutions of $dy/dt = ay - y^3 = 0$. For $a \leq 0$, there is one equilibrium point, $y = 0$. For $a > 0$, there are three equilibrium points, $y = 0$ and $y = \pm\sqrt{a}$. To draw the phase lines, note that:

- For $a \leq 0$, $dy/dt > 0$ if $y < 0$, and $dy/dt < 0$ if $y > 0$. Consequently, the equilibrium point $y = 0$ is a sink.
- For $a > 0$, $dy/dt > 0$ if $y < -\sqrt{a}$ or $0 < y < \sqrt{a}$. Similarly, $dy/dt < 0$ if $-\sqrt{a} < y < 0$ or $y > \sqrt{a}$. Consequently, the equilibrium point $y = 0$ is a source, and the equilibria $y = \pm\sqrt{a}$ are sinks.

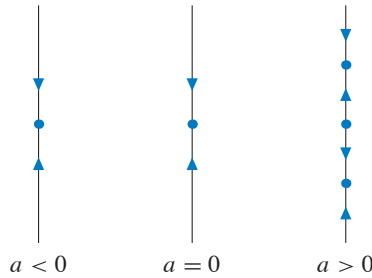

- (a) The phase lines for $a \leq 0$ are qualitatively the same, and the phase lines for $a > 0$ are qualitatively the same.
- (b) The phase line undergoes a qualitative change at $a = 0$.
43. (a) Because the first and second derivative are zero at y_0 and the third derivative is positive, Taylor's Theorem implies that the function $f(y)$ is approximately equal to

$$\frac{f'''(y_0)}{3!}(y - y_0)^3$$

for y near y_0 . Since $f'''(y_0) > 0$, $f(y)$ is increasing near y_0 . Hence, y_0 is a source.

- (b) Just as in part (a), we see that $f(y)$ is decreasing near y_0 , so y_0 is a sink.
- (c) In this case, we can approximate $f(y)$ near y_0 by

$$\frac{f''(y_0)}{2!}(y - y_0)^2.$$

Since the second derivative of $f(y)$ at y_0 is assumed to be positive, $f(y)$ is positive on both sides of y_0 for y near y_0 . Hence y_0 is a node.

44. (a) The differential equation is not defined for $y = -1$ and $y = 2$ and has no equilibria. So the phase line has holes at $y = -1$ and $y = 2$. The function $f(y) = 1/((y - 2)(y + 1))$ is positive for $y > 2$ and for $y < -1$. It is negative for $-1 < y < 2$. Thus, the phase line to the right corresponds to this differential equation.

Since the value, $1/2$, of the initial condition $y(0) = 1/2$ is in the interval where the function $f(y)$ is negative, the solution is decreasing. It reaches $y = -1$ in finite time. As t decreases, the solution reaches $y = 2$ in finite time. Strictly speaking, the solution does not continue beyond the values $y = -1$ and $y = 2$ because the differential equation is not defined for $y = -1$ and $y = 2$.

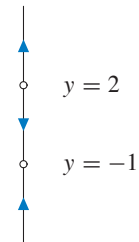

(b) We can solve the differential equation analytically. We separate variables and integrate. We get

$$\int (y - 2)(y + 1) dy = \int dt$$

$$\frac{y^3}{3} - \frac{y^2}{2} - 2y = t + c,$$

where c is a constant. Using $y(0) = 1/2$, we get $c = 13/12$. Therefore the solution to the initial-value problem is the unique solution $y(t)$ that satisfies the equation

$$4y^3 - 6y^2 - 24y - 24t + 13 = 0$$

with $-1 < y(t) < 2$. It is not easy to solve this equation explicitly. However, in order to obtain the domain of this solution, we substitute $y = -1$ and $y = 2$ into the equation, and we get $t = -9/8$ and $t = 9/8$ respectively.

45. One assumption of the model is that, if no people are present, then the time between trains decreases at a constant rate. Hence the term $-\alpha$ represents this assumption. The parameter α should be positive, so that $-\alpha$ makes a negative contribution to dx/dt .

The term βx represents the effect of the passengers. The parameter β should be positive so that βx contributes positively to dx/dt .

46. (a) Solving $\beta x - \alpha = 0$, we see that the equilibrium point is $x = \alpha/\beta$.
 (b) Since $f(x) = \beta x - \alpha$ is positive for $x > \alpha/\beta$ and negative for $x < \alpha/\beta$, the equilibrium point is a source.
 (c) and (d)

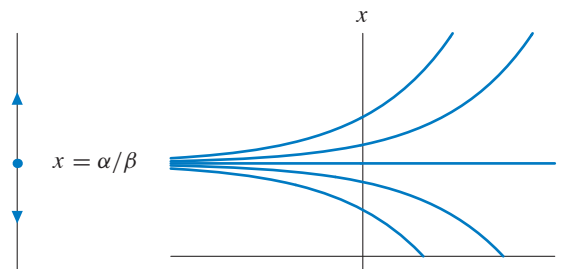

- (e) We separate the variables and integrate to obtain

$$\int \frac{dx}{\beta x - \alpha} = \int dt$$

$$\frac{1}{\beta} \ln |\beta x - \alpha| = t + c,$$

which yields the general solution $x(t) = \alpha/\beta + ke^{\beta t}$, where k is any constant.

47. Note that the only equilibrium point is a source. If the initial gap between trains is too large, then x will increase without bound. If it is too small, x will decrease to zero. When $x = 0$, the two trains are next to each other, and they will stay together since $x < 0$ is not physically possible in this problem.

If the time between trains is exactly the equilibrium value ($x = \alpha/\beta$), then theoretically $x(t)$ is constant. However, any disruption to x causes the solution to tend away from the source. Since it is very likely that some stops will have fewer than the expected number of passengers and some stops will have more, it is unlikely that the time between trains will remain constant for long.

48. If the trains are spaced too close together, then each train will catch up with the one in front of it. This phenomenon will continue until there is a very large time gap between two successive trains. When this happens, the time between these two trains will grow, and a second cluster of trains will form.

For the “B branch of the Green Line,” the clusters seem to contain three or four trains during rush hour. For the “D branch of the Green Line,” clusters seem to contain only two trains or three trains.

It is tempting to say that the trains should be spaced at time intervals of exactly α/β , and nothing else needs to be changed. In theory, this choice will result in equal spacing between trains, but we must remember that the equilibrium point, $x = \alpha/\beta$, is a source. Hence, anything that perturbs x will cause x to increase or decrease in an exponential fashion.

The only solution that is consistent with this model is to have the trains run to a schedule that allows for sufficient time for the loading of passengers. The trains will occasionally have to wait if they get ahead of schedule, but this plan avoids the phenomenon of one tremendously crowded train followed by two or three relatively empty ones.

EXERCISES FOR SECTION 1.7

1. The equilibrium points occur at solutions of $dy/dt = y^2 + a = 0$. For $a > 0$, there are no equilibrium points. For $a = 0$, there is one equilibrium point, $y = 0$. For $a < 0$, there are two equilibrium points, $y = \pm\sqrt{-a}$. Thus, $a = 0$ is a bifurcation value.

To draw the phase lines, note that:

- If $a > 0$, $dy/dt = y^2 + a > 0$, so the solutions are always increasing.
- If $a = 0$, $dy/dt > 0$ unless $y = 0$. Thus, $y = 0$ is a node.
- For $a < 0$, $dy/dt < 0$ for $-\sqrt{-a} < y < \sqrt{-a}$, and $dy/dt > 0$ for $y < -\sqrt{-a}$ and for $y > \sqrt{-a}$.

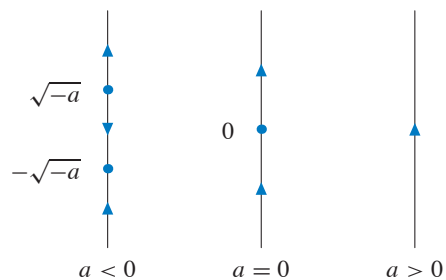

Phase lines for $a < 0$, $a = 0$, and $a > 0$.

2. The equilibrium points occur at solutions of $dy/dt = y^2 + 3y + a = 0$. From the quadratic formula, we have

$$y = \frac{-3 \pm \sqrt{9 - 4a}}{2}.$$

Hence, the bifurcation value of a is $9/4$. For $a < 9/4$, there are two equilibria, one source and one sink. For $a = 9/4$, there is one equilibrium which is a node, and for $a > 9/4$, there are no equilibria.

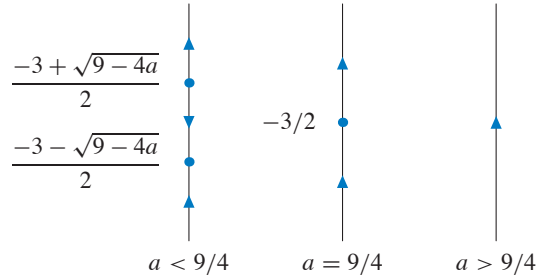

Phase lines for $a < 9/4$, $a = 9/4$, and $a > 9/4$.

3. The equilibrium points occur at solutions of $dy/dt = y^2 - ay + 1 = 0$. From the quadratic formula, we have

$$y = \frac{a \pm \sqrt{a^2 - 4}}{2}.$$

If $-2 < a < 2$, then $a^2 - 4 < 0$, and there are no equilibrium points. If $a > 2$ or $a < -2$, there are two equilibrium points. For $a = \pm 2$, there is one equilibrium point at $y = a/2$. The bifurcations occur at $a = \pm 2$.

To draw the phase lines, note that:

- For $-2 < a < 2$, $dy/dt = y^2 - ay + 1 > 0$, so the solutions are always increasing.
- For $a = 2$, $dy/dt = (y - 1)^2 \geq 0$, and $y = 1$ is a node.
- For $a = -2$, $dy/dt = (y + 1)^2 \geq 0$, and $y = -1$ is a node.
- For $a < -2$ or $a > 2$, let

$$y_1 = \frac{a - \sqrt{a^2 - 4}}{2} \quad \text{and} \quad y_2 = \frac{a + \sqrt{a^2 - 4}}{2}.$$

Then $dy/dt < 0$ if $y_1 < y < y_2$, and $dy/dt > 0$ if $y < y_1$ or $y > y_2$.

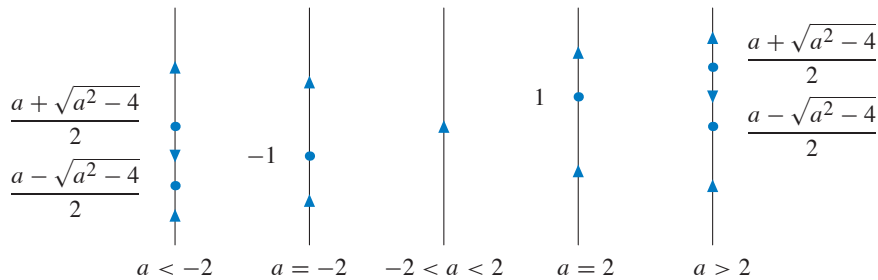

The five possible phase lines.

4. The equilibrium points occur at solutions of $dy/dt = y^3 + \alpha y^2 = 0$. For $\alpha = 0$, there is one equilibrium point, $y = 0$. For $\alpha \neq 0$, there are two equilibrium points, $y = 0$ and $y = -\alpha$. Thus, $\alpha = 0$ is a bifurcation value.

To draw the phase lines, note that:

- If $\alpha < 0$, $dy/dt > 0$ only if $y > -\alpha$.
- If $\alpha = 0$, $dy/dt > 0$ if $y > 0$, and $dy/dt < 0$ if $y < 0$.
- If $\alpha > 0$, $dy/dt < 0$ only if $y < -\alpha$.

Hence, as α increases from negative to positive, the source at $y = -\alpha$ moves from positive to negative as it “passes through” the node at $y = 0$.

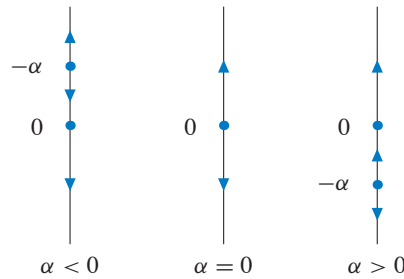

5. To find the equilibria we solve

$$(y^2 - \alpha)(y^2 - 4) = 0,$$

obtaining $y = \pm 2$ and $y = \pm\sqrt{\alpha}$ if $\alpha \geq 0$. Hence, there are two bifurcation values of α , $\alpha = 0$ and $\alpha = 4$.

For $\alpha < 0$, there are only two equilibria. The point $y = -2$ is a sink and $y = 2$ is a source. At $\alpha = 0$, there are three equilibria. There is a sink at $y = -2$, a source at $y = 2$, and a node at $y = 0$. For $0 < \alpha < 4$, there are four equilibria. The point $y = -2$ is still a sink, $y = -\sqrt{\alpha}$ is a source, $y = \sqrt{\alpha}$ is a sink, and $y = 2$ is still a source.

For $\alpha = 4$, there are only two equilibria, $y = \pm 2$. Both are nodes. For $\alpha > 4$, there are four equilibria again. The point $y = -\sqrt{\alpha}$ is a sink, $y = -2$ is now a source, $y = 2$ is now a sink, and $y = \sqrt{\alpha}$ is a source.

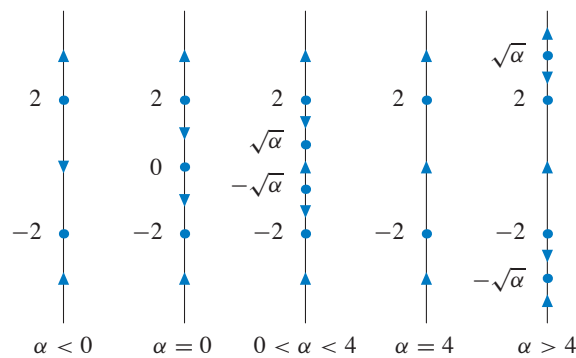

6. The equilibrium points occur at solutions of $dy/dt = \alpha - |y| = 0$. For $\alpha < 0$, there are no equilibrium points. For $\alpha = 0$, there is one equilibrium point, $y = 0$. For $\alpha > 0$, there are two equilibrium points, $y = \pm\alpha$. Therefore, $\alpha = 0$ is a bifurcation value.

To draw the phase lines, note that:

- If $\alpha < 0$, $dy/dt = \alpha - |y| < 0$, so the solutions are always decreasing.
- If $\alpha = 0$, $dy/dt < 0$ unless $y = 0$. Thus, $y = 0$ is a node.
- For $\alpha > 0$, $dy/dt > 0$ for $-\alpha < y < \alpha$, and $dy/dt < 0$ for $y < -\alpha$ and for $y > \alpha$.

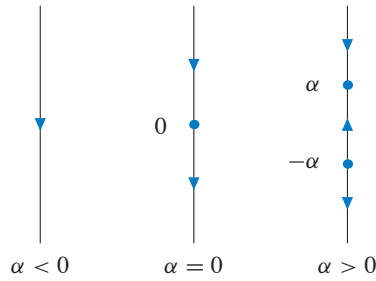

7. We have

$$\frac{dy}{dt} = y^4 + \alpha y^2 = y^2(y^2 + \alpha).$$

If $\alpha > 0$, there is one equilibrium point at $y = 0$, and $dy/dt > 0$ otherwise. Hence, $y = 0$ is a node.

If $\alpha < 0$, there are equilibria at $y = 0$ and $y = \pm\sqrt{-\alpha}$. From the sign of $y^4 + \alpha y^2$, we know that $y = 0$ is a node, $y = -\sqrt{-\alpha}$ is a sink, and $y = \sqrt{-\alpha}$ is a source.

The bifurcation value of α is $\alpha = 0$. As α increases through 0, a sink and a source come together with the node at $y = 0$, leaving only the node. For $\alpha < 0$, there are three equilibria, and for $\alpha \geq 0$, there is only one equilibrium.

8. The equilibrium points occur at solutions of

$$\frac{dy}{dt} = y^6 - 2y^3 + \alpha = (y^3)^2 - 2(y^3) + \alpha = 0.$$

Using the quadratic formula to solve for y^3 , we obtain

$$y^3 = \frac{2 \pm \sqrt{4 - 4\alpha}}{2}.$$

Thus the equilibrium points are at

$$y = \left(1 \pm \sqrt{1 - \alpha}\right)^{1/3}.$$

If $\alpha > 1$, there are no equilibrium points because this equation has no real solutions. If $\alpha < 1$, the differential equation has two equilibrium points. A bifurcation occurs at $\alpha = 1$ where the differential equation has one equilibrium point at $y = 1$.

9. The bifurcations occur at values of α for which the graph of $\sin y + \alpha$ is tangent to the y -axis. That is, $\alpha = -1$ and $\alpha = 1$.

For $\alpha < -1$, there are no equilibria, and all solutions become unbounded in the negative direction as t increases.

If $\alpha = -1$, there are equilibrium points at $y = \pi/2 \pm 2n\pi$ for every integer n . All equilibria are nodes, and as $t \rightarrow \infty$, all other solutions decrease toward the nearest equilibrium solution below the given initial condition.

For $-1 < \alpha < 1$, there are infinitely many sinks and infinitely many sources, and they alternate along the phase line. Successive sinks differ by 2π . Similarly, successive sources are separated by 2π .

As α increases from -1 to $+1$, nearby sink and source pairs move apart. This separation continues until α is close to 1 where each source is close to the next sink with larger value of y .

At $\alpha = 1$, there are infinitely many nodes, and they are located at $y = 3\pi/2 \pm 2n\pi$ for every integer n . For $\alpha > 1$, there are no equilibria, and all solutions become unbounded in the positive direction as t increases.

- 10.** Note that $0 < e^{-y^2} \leq 1$ for all y , and its maximum value occurs at $y = 0$. Therefore, for $\alpha < -1$, dy/dt is always negative, and the solutions are always decreasing.

If $\alpha = -1$, $dy/dt = 0$ if and only if $y = 0$. For $y \neq 0$, $dy/dt < 0$, and the equilibrium point at $y = 0$ is a node.

If $-1 < \alpha < 0$, then there are two equilibrium points which we compute by solving

$$e^{-y^2} + \alpha = 0.$$

We get $-y^2 = \ln(-\alpha)$. Consequently, $y = \pm\sqrt{\ln(-1/\alpha)}$. As $\alpha \rightarrow 0$ from below, $\ln(-1/\alpha) \rightarrow \infty$, and the two equilibria tend to $\pm\infty$.

If $\alpha \geq 0$, dy/dt is always positive, and the solutions are always increasing.

- 11.** For $\alpha = 0$, there are three equilibria. There is a sink to the left of $y = 0$, a source at $y = 0$, and a sink to the right of $y = 0$.

As α decreases, the source and sink on the right move together. A bifurcation occurs at $\alpha \approx -2$. At this bifurcation value, there is a sink to the left of $y = 0$ and a node to the right of $y = 0$. For α below this bifurcation value, there is only the sink to the left of $y = 0$.

As α increases from zero, the sink to the left of $y = 0$ and the source move together. There is a bifurcation at $\alpha \approx 2$ with a node to the left of $y = 0$ and a sink to the right of $y = 0$. For α above this bifurcation value, there is only the sink to the right of $y = 0$.

- 12.** Note that if α is very negative, then the equation $g(y) = -\alpha y$ has only one solution. It is $y = 0$. Furthermore, $dy/dt > 0$ for $y < 0$, and $dy/dt < 0$ for $y > 0$. Consequently, the equilibrium point at $y = 0$ is a sink.

In the figure, it appears that the tangent line to the graph of g at the origin has slope 1 and does not intersect the graph of g other than at the origin. If so, $\alpha = -1$ is a bifurcation value. For $\alpha \leq -1$, the differential equation has one equilibrium, which is a sink. For $\alpha > -1$, the equation has three equilibria, $y = 0$ and two others, one on each side of $y = 0$. The equilibrium point at the origin is a source, and the other two equilibria are sinks.

- 13.** (a) Each phase line has an equilibrium point at $y = 0$. This corresponds to equations (i), (iii), and (vi). Since $y = 0$ is the only equilibrium point for $A < 0$, this only corresponds to equation (iii).
- (b) The phase line corresponding to $A = 0$ is the only phase line with $y = 0$ as an equilibrium point, which corresponds to equations (ii), (iv), and (v). For the phase lines corresponding to

$A < 0$, there are no equilibrium points. Only equations (iv) and (v) satisfy this property. For the phase lines corresponding to $A > 0$, note that $dy/dt < 0$ for $-\sqrt{A} < y < \sqrt{A}$. Consequently, the bifurcation diagram corresponds to equation (v).

- (c) The phase line corresponding to $A = 0$ is the only phase line with $y = 0$ as an equilibrium point, which corresponds to equations (ii), (iv), and (v). For the phase lines corresponding to $A < 0$, there are no equilibrium points. Only equations (iv) and (v) satisfy this property. For the phase lines corresponding to $A > 0$, note that $dy/dt > 0$ for $-\sqrt{A} < y < \sqrt{A}$. Consequently, the bifurcation diagram corresponds to equation (iv).
- (d) Each phase line has an equilibrium point at $y = 0$. This corresponds to equations (i), (iii), and (vi). The phase lines corresponding to $A > 0$ only have two nonnegative equilibrium points. Consequently, the bifurcation diagram corresponds to equation (i).

14. To find the equilibria we solve

$$1 - \cos \theta + (1 + \cos \theta)(I) = 0$$

$$1 + I - (1 - I) \cos \theta = 0$$

$$\cos \theta = \frac{1 + I}{1 - I}.$$

For $I > 0$, the fraction on the right-hand side is greater than 1. Therefore, there are no equilibria. For $I = 0$, the equilibria correspond to the solutions of $\cos \theta = 1$, that is, $\theta = 2\pi n$ for integer values of n . For $I < 0$, the fraction on the right-hand side is between -1 and 1 . As $I \rightarrow -\infty$, the fraction on the right-hand side approaches -1 . Therefore the equilibria approach $\pm\pi$.

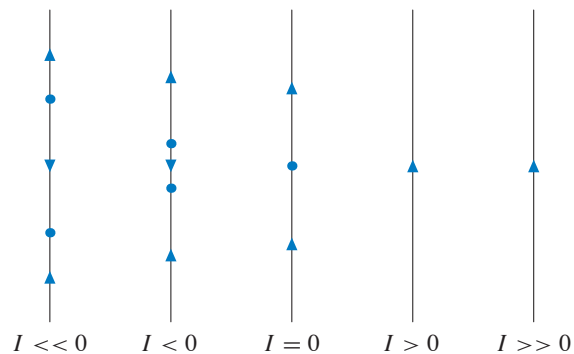

15. The graph of f needs to cross the y -axis exactly four times so that there are exactly four equilibria if $\alpha = 0$. The function must be greater than -3 everywhere so that there are no equilibria if $\alpha \geq 3$. Finally, the graph of f must cross horizontal lines three or more units above the y -axis exactly twice so that there are exactly two equilibria for $\alpha \leq -3$. The following graph is an example of the graph of such a function.

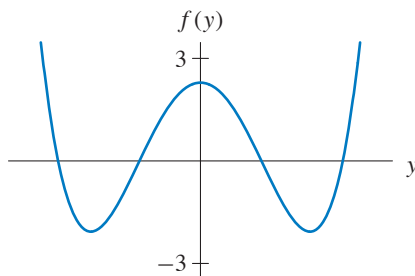

16. The graph of g can only intersect horizontal lines above 4 once, and it must go from above to below as y increases. Then there is exactly one sink for $\alpha \leq -4$.

Similarly, the graph of g can only intersect horizontal lines below -4 once, and it must go from above to below as y increases. Then there is exactly one sink for $\alpha \geq 4$.

Finally, the graph of g must touch the y -axis at exactly six points so that there are exactly six equilibria for $\alpha = 0$.

The following graph is the graph of one such function.

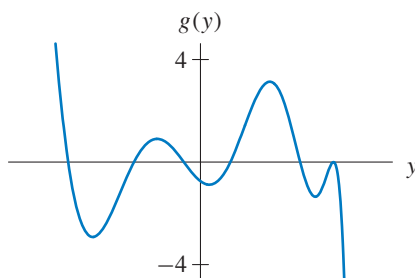

17. No such $f(y)$ exists. To see why, suppose that there is exactly one sink y_0 for $\alpha = 0$. Then, $f(y) > 0$ for $y < y_0$, and $f(y) < 0$ for $y > y_0$. Now consider the system $dy/dt = f(y) + 1$. Then $dy/dt \geq 1$ for $y < y_0$. If this system has an equilibrium point y_1 that is a source, then $y_1 > y_0$ and $dy/dt < 0$ for y slightly less than y_1 . Since $f(y)$ is continuous and $dy/dt \geq 1$ for $y \leq y_0$, then dy/dt must have another zero between y_0 and y_1 .
18. (a) For all $C \geq 0$, the equation has a source at $P = C/k$, and this is the only equilibrium point. Hence all of the phase lines are qualitatively the same, and there are no bifurcation values for C .
- (b) If $P(0) > C/k$, the corresponding solution $P(t) \rightarrow \infty$ at an exponential rate as $t \rightarrow \infty$, and if $P(0) < C/k$, $P(t) \rightarrow -\infty$, passing through “extinction” ($P = 0$) after a finite time.
19. (a) A model of the fish population that includes fishing is

$$\frac{dP}{dt} = 2P - \frac{P^2}{50} - 3L,$$

where L is the number of licenses issued. The coefficient of 3 represents the average catch of 3 fish per year. As L is increased, the two equilibrium points for $L = 0$ (at $P = 0$ and $P = 100$) will move together. If L is sufficiently large, there are no equilibrium points. Hence we wish to

pick L as large as possible so that there is still an equilibrium point present. In other words, we want the bifurcation value of L . The bifurcation value of L occurs if the equation

$$\frac{dP}{dt} = 2P - \frac{P^2}{50} - 3L = 0$$

has just one solution for P in terms of L . Using the quadratic formula, we see that there is exactly one equilibrium point if $L = 50/3$. Since this value of L is not an integer, the largest number of licenses that should be allowed is 16.

- (b) If we allow the fish population to come to equilibrium then the population will be at the carrying capacity, which is $P = 100$ if $L = 0$. If we then allow 16 licenses to be issued, we expect that the population is a solution to the new model with $L = 16$ and initial population $P = 100$. The model becomes

$$\frac{dP}{dt} = 2P - \frac{P^2}{50} - 48,$$

which has a source at $P = 40$ and a sink at $P = 60$.

Thus, any initial population greater than 40 when fishing begins tends to the equilibrium level $P = 60$. If the initial population of fish was less than 40 when fishing begins, then the model predicts that the population will decrease to zero in a finite amount of time.

- (c) The maximum “number” of licenses is $16\frac{2}{3}$. With $L = 16\frac{2}{3}$, there is an equilibrium at $P = 50$. This equilibrium is a node, and if $P(0) > 50$, the population will approach 50 as t increases. However, it is dangerous to allow this many licenses since an unforeseen event might cause the death of a few extra fish. That event would push the number of fish below the equilibrium value of $P = 50$. In this case, $dP/dt < 0$, and the population decreases to extinction.

If, however, we restrict to $L = 16$ licenses, then there are two equilibria, a sink at $P = 60$ and source at $P = 40$. As long as $P(0) > 40$, the population will tend to 60 as t increases. In this case, we have a small margin of safety. If $P \approx 60$, then it would have to drop to less than 40 before the fish are in danger of extinction.

20. (a)

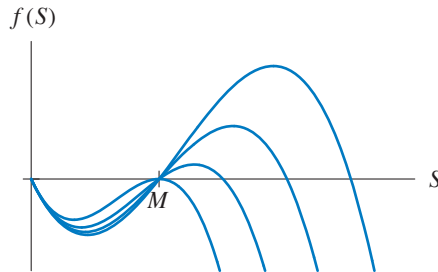

- (b) The bifurcation occurs at $N = M$. The sink at $S = N$ coincides with the source at $S = M$ and becomes a node.
- (c) Assuming that the population $S(t)$ is approximately N , the population adjusts to stay near the sink at $S = N$ as N slowly decreases. If $N < M$, the model is no longer consistent with the underlying assumptions.

21. If $C < kN/4$, the differential equation has two equilibria

$$P_1 = \frac{N}{2} - \sqrt{\frac{N^2}{4} - \frac{CN}{k}} \quad \text{and} \quad P_2 = \frac{N}{2} + \sqrt{\frac{N^2}{4} - \frac{CN}{k}}.$$

The smaller one, P_1 , is a source, and the larger one, P_2 , is a sink. Note that they are equidistant from $N/2$. Also, note that any population below P_1 tends to extinction.

If C is near $kN/4$, then P_1 and P_2 are near $N/2$. Consequently, if the population is near zero, it will tend to extinction. As C is decreased, P_1 and P_2 move apart until they reach $P_1 = 0$ and $P_2 = N$ for $C = 0$.

Once P is near zero, the parameter C must be reset essentially to zero so that P will be greater than P_1 . Simply reducing C slightly below $kN/4$ leaves P in the range where $dP/dt < 0$ and the population will still die out.

22. (a) If $a = 0$, there is a single equilibrium point at $y = 0$. For $a \neq 0$, the equilibrium points occur at $y = 0$ and $y = a$. If $a < 0$, the equilibrium point at $y = 0$ is a sink and the equilibrium point at $y = a$ is a source. If $a > 0$, the equilibrium point at $y = 0$ is a source and the equilibrium point at $y = a$ is a sink.

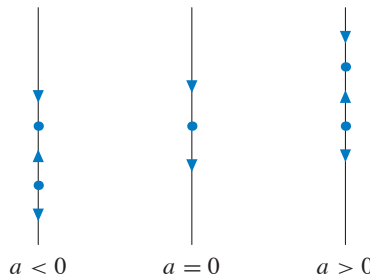

Phase lines for $dy/dt = ay - y^2$.

- (b) Given the results in part (a), there is one bifurcation value, $a = 0$.
 (c) The equilibrium points satisfy the equation

$$r + ay - y^2 = 0.$$

Solving it, we obtain

$$y = \frac{a \pm \sqrt{a^2 + 4r}}{2}.$$

Hence, there are no equilibrium points if $a^2 + 4r < 0$, one equilibrium point if $a^2 + 4r = 0$, and two equilibrium points if $a^2 + 4r > 0$.

If $r > 0$, we always have two equilibrium points.

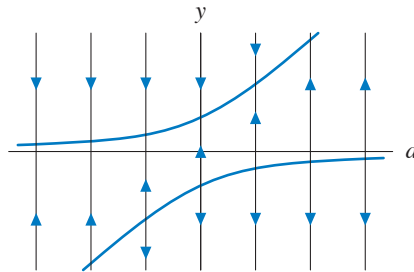

The bifurcation diagram for $r > 0$.

- (d) If $r < 0$, there are no equilibrium points if $a^2 + 4r < 0$. In other words, there are no equilibrium points if $-2\sqrt{-r} < a < 2\sqrt{-r}$. If $a = \pm 2\sqrt{-r}$, there is a single equilibrium point, and if $|a| > 2\sqrt{-r}$, there are two equilibrium points.

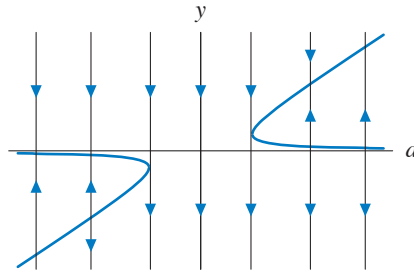

The bifurcation diagram for $r < 0$.

23. (a) If $a \leq 0$, there is a single equilibrium point at $y = 0$, and it is a sink. For $a > 0$, there are equilibrium points at $y = 0$ and $y = \pm\sqrt{a}$. The equilibrium point at $y = 0$ is a source, and the other two are sinks.

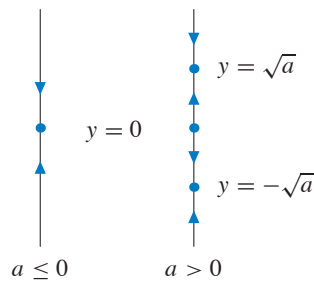

Phase lines for $dy/dt = ay - y^3$.

- (b) Given the results in part (a), there is one bifurcation value, $a = 0$.
 (c) The equilibrium points satisfy the cubic equation

$$r + ay - y^3 = 0.$$

Rather than solving it explicitly, we rely on `PhaseLines`.

If $r > 0$, there is a positive bifurcation value $a = a_0$. For $a < a_0$, the phase line has one equilibrium point, a positive sink. If $a > a_0$, there are two negative equilibria in addition to the positive sink. The larger of the two negative equilibria is a source and the smaller is a sink.

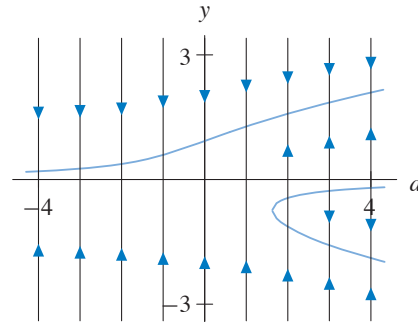
The bifurcation diagram for $r = 0.8$.

- (d) If $r < 0$, there is a positive bifurcation value $a = a_0$. For $a < a_0$, the phase line has one equilibrium point, a negative sink. If $a > a_0$, there are two positive equilibria in addition to the negative sink. The larger of the two positive equilibria is a sink and the smaller is a source.

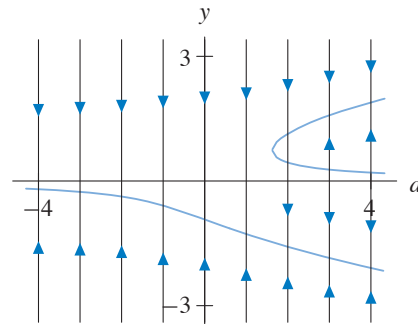
The bifurcation diagram for $r = -0.8$.

EXERCISES FOR SECTION 1.8

1. The general solution to the associated homogeneous equation is $y_h(t) = ke^{-4t}$. For a particular solution of the nonhomogeneous equation, we guess a solution of the form $y_p(t) = \alpha e^{-t}$. Then

$$\begin{aligned} \frac{dy_p}{dt} + 4y_p &= -\alpha e^{-t} + 4\alpha e^{-t} \\ &= 3\alpha e^{-t}. \end{aligned}$$

Consequently, we must have $3\alpha = 9$ for $y_p(t)$ to be a solution. Hence, $\alpha = 3$, and the general solution to the nonhomogeneous equation is

$$y(t) = ke^{-4t} + 3e^{-t}.$$

2. The general solution to the associated homogeneous equation is $y_h(t) = ke^{-4t}$. For a particular solution of the nonhomogeneous equation, we guess a solution of the form $y_p(t) = \alpha e^{-t}$. Then

$$\begin{aligned}\frac{dy_p}{dt} + 4y_p &= -\alpha e^{-t} + 4\alpha e^{-t} \\ &= 3\alpha e^{-t}.\end{aligned}$$

Consequently, we must have $3\alpha = 3$ for $y_p(t)$ to be a solution. Hence, $\alpha = 1$, and the general solution to the nonhomogeneous equation is

$$y(t) = ke^{-4t} + e^{-t}.$$

3. The general solution to the associated homogeneous equation is $y_h(t) = ke^{-3t}$. For a particular solution of the nonhomogeneous equation, we guess a solution of the form $y_p(t) = \alpha \cos 2t + \beta \sin 2t$. Then

$$\begin{aligned}\frac{dy_p}{dt} + 3y_p &= -2\alpha \sin 2t + 2\beta \cos 2t + (3\alpha \cos 2t + 3\beta \sin 2t) \\ &= (3\alpha + 2\beta) \cos 2t + (3\beta - 2\alpha) \sin 2t\end{aligned}$$

Consequently, we must have

$$(3\alpha + 2\beta) \cos 2t + (3\beta - 2\alpha) \sin 2t = 4 \cos 2t$$

for $y_p(t)$ to be a solution. We must solve

$$\begin{cases} 3\alpha + 2\beta = 4 \\ 3\beta - 2\alpha = 0. \end{cases}$$

Hence, $\alpha = 12/13$ and $\beta = 8/13$. The general solution is

$$y(t) = ke^{-3t} + \frac{12}{13} \cos 2t + \frac{8}{13} \sin 2t.$$

4. The general solution to the associated homogeneous equation is $y_h(t) = ke^{2t}$. For a particular solution of the nonhomogeneous equation, we guess $y_p(t) = \alpha \cos 2t + \beta \sin 2t$. Then

$$\begin{aligned}\frac{dy_p}{dt} - 2y_p &= -2\alpha \sin 2t + 2\beta \cos 2t - 2(\alpha \cos 2t + \beta \sin 2t) \\ &= (2\beta - 2\alpha) \cos 2t + (-2\alpha - 2\beta) \sin 2t.\end{aligned}$$

Consequently, we must have

$$(2\beta - 2\alpha) \cos 2t + (-2\alpha - 2\beta) \sin 2t = \sin 2t$$

for $y_p(t)$ to be a solution, that is, we must solve

$$\begin{cases} -2\alpha - 2\beta = 1 \\ -2\alpha + 2\beta = 0. \end{cases}$$

Hence, $\alpha = -1/4$ and $\beta = -1/4$. The general solution of the nonhomogeneous equation is

$$y(t) = ke^{2t} - \frac{1}{4} \cos 2t - \frac{1}{4} \sin 2t.$$

5. The general solution to the associated homogeneous equation is $y_h(t) = ke^{3t}$. For a particular solution of the nonhomogeneous equation, we guess $y_p(t) = \alpha te^{3t}$ rather than αe^{3t} because αe^{3t} is a solution of the homogeneous equation. Then

$$\begin{aligned} \frac{dy_p}{dt} - 3y_p &= \alpha e^{3t} + 3\alpha te^{3t} - 3\alpha te^{3t} \\ &= \alpha e^{3t}. \end{aligned}$$

Consequently, we must have $\alpha = -4$ for $y_p(t)$ to be a solution. Hence, the general solution to the nonhomogeneous equation is

$$y(t) = ke^{3t} - 4te^{3t}.$$

6. The general solution of the associated homogeneous equation is $y_h(t) = ke^{t/2}$. For a particular solution of the nonhomogeneous equation, we guess $y_p(t) = \alpha te^{t/2}$ rather than $\alpha e^{t/2}$ because $\alpha e^{t/2}$ is a solution of the homogeneous equation. Then

$$\begin{aligned} \frac{dy_p}{dt} - \frac{y_p}{2} &= \alpha e^{t/2} + \frac{\alpha}{2} te^{t/2} - \frac{\alpha te^{t/2}}{2} \\ &= \alpha e^{t/2}. \end{aligned}$$

Consequently, we must have $\alpha = 4$ for $y_p(t)$ to be a solution. Hence, the general solution to the nonhomogeneous equation is

$$y(t) = ke^{t/2} + 4te^{t/2}.$$

7. The general solution to the associated homogeneous equation is $y_h(t) = ke^{-2t}$. For a particular solution of the nonhomogeneous equation, we guess a solution of the form $y_p(t) = \alpha e^{t/3}$. Then

$$\begin{aligned} \frac{dy_p}{dt} + 2y_p &= \frac{1}{3}\alpha e^{t/3} + 2\alpha e^{t/3} \\ &= \frac{7}{3}\alpha e^{t/3}. \end{aligned}$$

Consequently, we must have $\frac{7}{3}\alpha = 1$ for $y_p(t)$ to be a solution. Hence, $\alpha = 3/7$, and the general solution to the nonhomogeneous equation is

$$y(t) = ke^{-2t} + \frac{3}{7}e^{t/3}.$$

Since $y(0) = 1$, we have

$$1 = k + \frac{3}{7},$$

so $k = 4/7$. The function $y(t) = \frac{4}{7}e^{-2t} + \frac{3}{7}e^{t/3}$ is the solution of the initial-value problem.

8. The general solution to the associated homogeneous equation is $y_h(t) = ke^{2t}$. For a particular solution of the nonhomogeneous equation, we guess a solution of the form $y_p(t) = \alpha e^{-2t}$. Then

$$\begin{aligned}\frac{dy_p}{dt} - 2y_p &= -2\alpha e^{-2t} - 2\alpha e^{-2t} \\ &= -4\alpha e^{-2t}.\end{aligned}$$

Consequently, we must have $-4\alpha = 3$ for $y_p(t)$ to be a solution. Hence, $\alpha = -3/4$, and the general solution to the nonhomogeneous equation is

$$y(t) = ke^{2t} - \frac{3}{4}e^{-2t}.$$

Since $y(0) = 10$, we have

$$10 = k - \frac{3}{4},$$

so $k = 43/4$. The function

$$y(t) = \frac{43}{4}e^{2t} - \frac{3}{4}e^{-2t}$$

is the solution of the initial-value problem.

9. The general solution of the associated homogeneous equation is $y_h(t) = ke^{-t}$. For a particular solution of the nonhomogeneous equation, we guess a solution of the form $y_p(t) = \alpha \cos 2t + \beta \sin 2t$. Then

$$\begin{aligned}\frac{dy_p}{dt} + y_p &= -2\alpha \sin 2t + 2\beta \cos 2t + \alpha \cos 2t + \beta \sin 2t \\ &= (\alpha + 2\beta) \cos 2t + (-2\alpha + \beta) \sin 2t.\end{aligned}$$

Consequently, we must have

$$(\alpha + 2\beta) \cos 2t + (-2\alpha + \beta) \sin 2t = \cos 2t$$

for $y_p(t)$ to be a solution. We must solve

$$\begin{cases} \alpha + 2\beta = 1 \\ -2\alpha + \beta = 0. \end{cases}$$

Hence, $\alpha = 1/5$ and $\beta = 2/5$. The general solution to the differential equation is

$$y(t) = ke^{-t} + \frac{1}{5} \cos 2t + \frac{2}{5} \sin 2t.$$

To find the solution of the given initial-value problem, we evaluate the general solution at $t = 0$ and obtain

$$y(0) = k + \frac{1}{5}.$$

Since the initial condition is $y(0) = 5$, we see that $k = 24/5$. The desired solution is

$$y(t) = \frac{24}{5}e^{-t} + \frac{1}{5} \cos 2t + \frac{2}{5} \sin 2t.$$

- 10.** The general solution of the associated homogeneous equation is $y_h(t) = ke^{-3t}$. For a particular solution of the nonhomogeneous equation, we guess a solution of the form $y_p(t) = \alpha \cos 2t + \beta \sin 2t$. Then

$$\begin{aligned}\frac{dy_p}{dt} + 3y_p &= -2\alpha \sin 2t + 2\beta \cos 2t + 3\alpha \cos 2t + 3\beta \sin 2t \\ &= (3\alpha + 2\beta) \cos 2t + (-2\alpha + 3\beta) \sin 2t.\end{aligned}$$

Consequently, we must have

$$(3\alpha + 2\beta) \cos 2t + (-2\alpha + 3\beta) \sin 2t = \cos 2t$$

for $y_p(t)$ to be a solution. We must solve

$$\begin{cases} 3\alpha + 2\beta = 1 \\ -2\alpha + 3\beta = 0. \end{cases}$$

Hence, $\alpha = 3/13$ and $\beta = 2/13$. The general solution to the differential equation is

$$y(t) = ke^{-3t} + \frac{3}{13} \cos 2t + \frac{2}{13} \sin 2t.$$

To find the solution of the given initial-value problem, we evaluate the general solution at $t = 0$ and obtain

$$y(0) = k + \frac{3}{13}.$$

Since the initial condition is $y(0) = -1$, we see that $k = -16/13$. The desired solution is

$$y(t) = -\frac{16}{13}e^{-3t} + \frac{3}{13} \cos 2t + \frac{2}{13} \sin 2t.$$

- 11.** The general solution to the associated homogeneous equation is $y_h(t) = ke^{2t}$. For a particular solution of the nonhomogeneous equation, we guess $y_p(t) = \alpha te^{2t}$ rather than αe^{2t} because αe^{2t} is a solution of the homogeneous equation. Then

$$\begin{aligned}\frac{dy_p}{dt} - 2y_p &= \alpha e^{2t} + 2\alpha te^{2t} - 2\alpha te^{2t} \\ &= \alpha e^{2t}.\end{aligned}$$

Consequently, we must have $\alpha = 7$ for $y_p(t)$ to be a solution. Hence, the general solution to the nonhomogeneous equation is

$$y(t) = ke^{2t} + 7te^{2t}.$$

Note that $y(0) = k = 3$, so the solution to the initial-value problem is

$$y(t) = 3e^{2t} + 7te^{2t} = (3 + 7t)e^{2t}.$$

12. The general solution to the associated homogeneous equation is $y_h(t) = ke^{2t}$. For a particular solution of the nonhomogeneous equation, we guess $y_p(t) = \alpha te^{2t}$ rather than αe^{2t} because αe^{2t} is a solution of the homogeneous equation. Then

$$\begin{aligned}\frac{dy_p}{dt} - 2y_p &= \alpha e^{2t} + 2\alpha te^{2t} - 2\alpha te^{2t} \\ &= \alpha e^{2t}.\end{aligned}$$

Consequently, we must have $\alpha = 7$ for $y_p(t)$ to be a solution. Hence, the general solution to the nonhomogeneous equation is

$$y(t) = ke^{2t} + 7te^{2t}.$$

Note that $y(0) = k$, so the solution to the initial-value problem is

$$y(t) = 3e^{2t} + 7te^{2t} = (7t + 3)e^{2t}.$$

13. (a) For the guess $y_p(t) = \alpha \cos 3t$, we have $dy_p/dt = -3\alpha \sin 3t$, and substituting this guess into the differential equation, we get

$$-3\alpha \sin 3t + 2\alpha \cos 3t = \cos 3t.$$

If we evaluate this equation at $t = \pi/6$, we get $-3\alpha = 0$. Therefore, $\alpha = 0$. However, $\alpha = 0$ does not produce a solution to the differential equation. Consequently, there is no value of α for which $y_p(t) = \alpha \cos 3t$ is a solution.

- (b) If we guess $y_p(t) = \alpha \cos 3t + \beta \sin 3t$, then the derivative

$$\frac{dy_p}{dt} = -3\alpha \sin 3t + 3\beta \cos 3t$$

is also a simple combination of terms involving $\cos 3t$ and $\sin 3t$. Substitution of this guess into the equation leads to two linear algebraic equations in two unknowns, and such systems of equations usually have a unique solution.

14. Consider two different solutions $y_1(t)$ and $y_2(t)$ of the nonhomogeneous equation. We have

$$\frac{dy_1}{dt} = \lambda y_1 + \cos 2t \quad \text{and} \quad \frac{dy_2}{dt} = \lambda y_2 + \cos 2t.$$

By subtracting the first equation from the second, we see that

$$\begin{aligned}\frac{dy_2}{dt} - \frac{dy_1}{dt} &= \lambda y_2 + \cos 2t - \lambda y_1 - \cos 2t \\ &= \lambda y_2 - \lambda y_1.\end{aligned}$$

In other words,

$$\frac{d(y_2 - y_1)}{dt} = \lambda(y_2 - y_1),$$

and consequently, the difference $y_2 - y_1$ is a solution to the associated homogeneous equation.

Whether we write the general solution of the nonhomogeneous equation as

$$y(t) = y_1(t) + k_1 e^{\lambda t} \quad \text{or as} \quad y(t) = y_2(t) + k_2 e^{\lambda t},$$

we get the same set of solutions because $y_1(t) - y_2(t) = k_3 e^{\lambda t}$ for some k_3 . In other words, both representations of the solutions produce the same collection of functions.

15. The Linearity Principle says that all nonzero solutions of a homogeneous linear equation are constant multiples of each other.

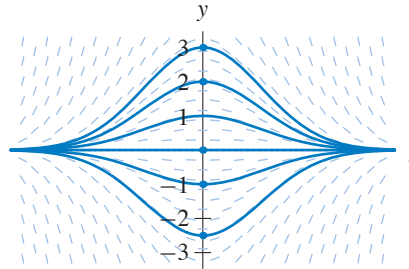

16. The Extended Linearity Principle says that any two solutions of a nonhomogeneous linear equation differ by a solution of the associated homogeneous equation.

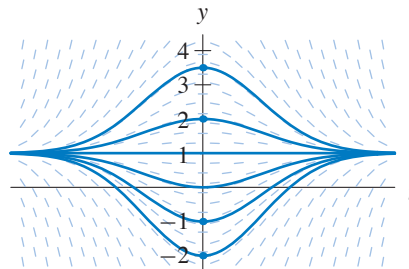

17. (a) We compute

$$\frac{dy_1}{dt} = \frac{1}{(1-t)^2} = (y_1(t))^2$$

to see that $y_1(t)$ is a solution.

- (b) We compute

$$\frac{dy_2}{dt} = 2 \frac{1}{(1-t)^2} \neq (y_2(t))^2$$

to see that $y_2(t)$ is not a solution.

- (c) The equation $dy/dt = y^2$ is not linear. It contains y^2 .
18. (a) The constant function $y(t) = 2$ for all t is an equilibrium solution.
- (b) If $y(t) = 2 - e^{-t}$, then $dy/dt = e^{-t}$. Also, $-y(t) + 2 = e^{-t}$. Consequently, $y(t) = 2 - e^{-t}$ is a solution.
- (c) Note that the solution $y(t) = 2 - e^{-t}$ has initial condition $y(0) = 1$. If the Linearity Principle held for this equation, then we could multiply the equilibrium solution $y(t) = 2$ by $1/2$ and obtain another solution that satisfies the initial condition $y(0) = 1$. Two solutions that satisfy the same initial condition would violate the Uniqueness Theorem.

19. Let $y(t) = y_h(t) + y_1(t) + y_2(t)$. Then

$$\begin{aligned} \frac{dy}{dt} + a(t)y &= \frac{dy_h}{dt} + \frac{dy_1}{dt} + \frac{dy_2}{dt} + a(t)y_h + a(t)y_1 + a(t)y_2 \\ &= \frac{dy_h}{dt} + a(t)y_h + \frac{dy_1}{dt} + a(t)y_1 + \frac{dy_2}{dt} + a(t)y_2 \\ &= 0 + b_1(t) + b_2(t). \end{aligned}$$

This computation shows that $y_h(t) + y_1(t) + y_2(t)$ is a solution of the original differential equation.

20. If $y_p(t) = at^2 + bt + c$, then

$$\begin{aligned} \frac{dy_p}{dt} + 2y_p &= 2at + b + 2at^2 + 2bt + 2c \\ &= 2at^2 + (2a + 2b)t + (b + 2c). \end{aligned}$$

Then $y_p(t)$ is a solution if this quadratic is equal to $3t^2 + 2t - 1$. In other words, $y_p(t)$ is a solution if

$$\begin{cases} 2a = 3 \\ 2a + 2b = 2 \\ b + 2c = -1. \end{cases}$$

From the first equation, we have $a = 3/2$. Then from the second equation, we have $b = -1/2$. Finally, from the third equation, we have $c = -1/4$. The function

$$y_p(t) = \frac{3}{2}t^2 - \frac{1}{2}t - \frac{1}{4}$$

is a solution of the differential equation.

21. To find the general solution, we use the technique suggested in Exercise 19. We calculate two particular solutions—one for the right-hand side $t^2 + 2t + 1$ and one for the right-hand side e^{4t} .

With the right-hand side $t^2 + 2t + 1$, we guess a solution of the form

$$y_{p_1}(t) = at^2 + bt + c.$$

Then

$$\begin{aligned} \frac{dy_{p_1}}{dt} + 2y_{p_1} &= 2at + b + 2(at^2 + bt + c) \\ &= 2at^2 + (2a + 2b)t + (b + 2c). \end{aligned}$$

Then y_{p_1} is a solution if

$$\begin{cases} 2a = 1 \\ 2a + 2b = 2 \\ b + 2c = 1. \end{cases}$$

We get $a = 1/2$, $b = 1/2$, and $c = 1/4$.

With the right-hand side e^{4t} , we guess a solution of the form

$$y_{p_2}(t) = \alpha e^{4t}.$$

Then

$$\frac{dy_{p_2}}{dt} + 2y_{p_2} = 4\alpha e^{4t} + 2\alpha e^{4t} = 6\alpha e^{4t},$$

and y_{p_2} is a solution if $\alpha = 1/6$.

The general solution of the associated homogeneous equation is $y_h(t) = ke^{-2t}$, so the general solution of the original equation is

$$ke^{-2t} + \frac{1}{2}t^2 + \frac{1}{2}t + \frac{1}{4} + \frac{1}{6}e^{4t}.$$

To find the solution that satisfies the initial condition $y(0) = 0$, we evaluate the general solution at $t = 0$ and obtain

$$k + \frac{1}{4} + \frac{1}{6} = 0.$$

Hence, $k = -5/12$.

- 22.** To find the general solution, we use the technique suggested in Exercise 19. We calculate two particular solutions—one for the right-hand side t^3 and one for the right-hand side $\sin 3t$.

With the right-hand side t^3 , we are tempted to guess that there is a solution of the form at^3 , but there isn't. Instead we guess a solution of the form

$$y_{p_1}(t) = at^3 + bt^2 + ct + d.$$

Then

$$\begin{aligned} \frac{dy_{p_1}}{dt} + y_{p_1} &= 3at^2 + 2bt + c + at^3 + bt^2 + ct + d \\ &= at^3 + (3a + b)t^2 + (2b + c)t + (c + d) \end{aligned}$$

Then y_{p_1} is a solution if

$$\begin{cases} a = 1 \\ 3a + b = 0 \\ 2b + c = 0 \\ c + d = 0. \end{cases}$$

We get $a = 1$, $b = -3$, $c = 6$, and $d = -6$.

With the right-hand side $\sin 3t$, we guess a solution of the form

$$y_{p_2}(t) = \alpha \cos 3t + \beta \sin 3t.$$

Then

$$\begin{aligned} \frac{dy_{p_2}}{dt} + y_{p_2} &= -3\alpha \sin 3t + 3\beta \cos 3t + \alpha \cos 3t + \beta \sin 3t \\ &= (\alpha + 3\beta) \cos 3t + (-3\alpha + \beta) \sin 3t. \end{aligned}$$

Then y_{p_2} is a solution if

$$\begin{cases} \alpha + 3\beta = 0 \\ -3\alpha + \beta = 1. \end{cases}$$

We get $\alpha = -3/10$ and $\beta = 1/10$.

The general solution of the associated homogeneous equation is $y_h(t) = ke^{-t}$, so the general solution of the original equation is

$$ke^{-t} + t^3 - 3t^2 + 6t - 6 - \frac{3}{10} \cos 3t + \frac{1}{10} \sin 3t.$$

To find the solution that satisfies the initial condition $y(0) = 0$, we evaluate the general solution at $t = 0$ and obtain

$$k - 6 - \frac{3}{10} = 0.$$

Hence, $k = 63/10$.

- 23.** To find the general solution, we use the technique suggested in Exercise 19. We calculate two particular solutions—one for the right-hand side $2t$ and one for the right-hand side $-e^{4t}$.

With the right-hand side $2t$, we guess a solution of the form

$$y_{p_1}(t) = at + b.$$

Then

$$\begin{aligned} \frac{dy_{p_1}}{dt} - 3y_{p_1} &= a - 3(at + b) \\ &= -3at + (a - 3b). \end{aligned}$$

Then y_{p_1} is a solution if

$$\begin{cases} -3a = 2 \\ a - 3b = 0. \end{cases}$$

We get $a = -2/3$, and $b = -2/9$.

With the right-hand side $-e^{4t}$, we guess a solution of the form

$$y_{p_2}(t) = \alpha e^{4t}.$$

Then

$$\frac{dy_{p_2}}{dt} - 3y_{p_2} = 4\alpha e^{4t} - 3\alpha e^{4t} = \alpha e^{4t},$$

and y_{p_2} is a solution if $\alpha = -1$.

The general solution of the associated homogeneous equation is $y_h(t) = ke^{3t}$, so the general solution of the original equation is

$$y(t) = ke^{3t} - \frac{2}{3}t - \frac{2}{9} - e^{4t}.$$

To find the solution that satisfies the initial condition $y(0) = 0$, we evaluate the general solution at $t = 0$ and obtain

$$y(0) = k - \frac{2}{9} - 1.$$

Hence, $k = 11/9$ if $y(0) = 0$.

- 24.** To find the general solution, we use the technique suggested in Exercise 19. We calculate two particular solutions—one for the right-hand side $\cos 2t + 3 \sin 2t$ and one for the right-hand side e^{-t} .

With the right-hand side $\cos 2t + 3 \sin 2t$, we guess a solution of the form

$$y_{p_1}(t) = \alpha \cos 2t + \beta \sin 2t.$$

Then

$$\begin{aligned} \frac{dy_{p_1}}{dt} + y_{p_1} &= -2\alpha \sin 2t + 2\beta \cos 2t + \alpha \cos 2t + \beta \sin 2t \\ &= (\alpha + 2\beta) \cos 2t + (-2\alpha + \beta) \sin 2t. \end{aligned}$$

Then y_{p_1} is a solution if

$$\begin{cases} \alpha + 2\beta = 1 \\ -2\alpha + \beta = 3. \end{cases}$$

We get $\alpha = -1$ and $\beta = 1$.

With the right-hand side e^{-t} , making a guess of the form $y_{p_2}(t) = ae^{-t}$ does not lead to a solution of the nonhomogeneous equation because the general solution of the associated homogeneous equation is $y_h(t) = ke^{-t}$.

Consequently, we guess

$$y_{p_2}(t) = ate^{-t}.$$

Then

$$\frac{dy_{p_2}}{dt} + y_{p_2} = a(1-t)e^{-t} + ate^{-t} = ae^{-t},$$

and y_{p_2} is a solution if $a = 1$.

The general solution of the original equation is

$$ke^{-t} - \cos 2t + \sin 2t + te^{-t}.$$

To find the solution that satisfies the initial condition $y(0) = 0$, we evaluate the general solution at $t = 0$ and obtain

$$k - 1 = 0.$$

Hence, $k = 1$.

- 25.** Since the general solution of the associated homogeneous equation is $y_h(t) = ke^{-2t}$ and since these $y_h(t) \rightarrow 0$ as $t \rightarrow \infty$, we only have to determine the long-term behavior of one solution to the nonhomogeneous equation. However, that is easier said than done.

Consider the slopes in the slope field for the equation. We rewrite the equation as

$$\frac{dy}{dt} = -2y + b(t).$$

Using the fact that $b(t) < 2$ for all t , we observe that $dy/dt < 0$ if $y > 1$ and, as y increases beyond $y = 1$, the slopes become more negative. Similarly, using the fact that $b(t) > -1$ for all t , we observe that $dy/dt > 0$ if $y < -1/2$ and, as y decreases below $y = -1/2$, the slopes become more positive. Thus, the graphs of all solutions must approach the strip $-1/2 \leq y \leq 1$ in the ty -plane as t increases. More precise information about the long-term behavior of solutions is difficult to obtain without specific knowledge of $b(t)$.

26. Since the general solution of the associated homogeneous equation is $y_h(t) = ke^{2t}$ and since these $y_h(t) \rightarrow \pm\infty$ as $t \rightarrow \infty$ if $k \neq 0$, the long-term behavior of one solution says a lot about the long-term behavior of all solutions.

Consider the slopes in the slope field for the equation. We rewrite the equation as

$$\frac{dy}{dt} = 2y + b(t).$$

Using the fact that $b(t) > -1$ for all t , we observe that $dy/dt > 0$ if $y > 1/2$, and as y increases beyond $y = 1/2$, the slopes increase. Similarly, using the fact that $b(t) < 2$ for all t , we observe that $dy/dt < 0$ if $y < -1$, and as y decreases below $y = -1$, the slopes decrease.

Thus, if a value of a solution $y(t)$ is larger than $1/2$, then $y(t) \rightarrow \infty$ as $t \rightarrow \infty$, and if a value of a solution $y(t)$ is less than -1 , then $y(t) \rightarrow -\infty$ as $t \rightarrow \infty$. If one solution $y_p(t)$ satisfies $-1 \leq y_p(t) \leq 1/2$, then all other solutions become unbounded as $t \rightarrow \infty$. (In fact, there is exactly one solution that satisfies $-1 \leq y(t) \leq 1/2$ for all t , but demonstrating its existence is somewhat difficult.)

27. Since the general solution of the associated homogeneous equation is $y_h(t) = ke^{-t}$ and since these $y_h(t) \rightarrow 0$ as $t \rightarrow \infty$, we only have to determine the long-term behavior of one solution to the nonhomogeneous equation. However, that is easier said than done.

Consider the slopes in the slope field for the equation. We rewrite the equation as

$$\frac{dy}{dt} = -y + b(t).$$

For any number $T > 3$, let ϵ be a positive number less than $T - 3$, and fix t_0 such that $b(t) < T - \epsilon$ if $t > t_0$. If $t > t_0$ and $y(t) > T$, then

$$\frac{dy}{dt} < -T + T - \epsilon = -\epsilon.$$

Hence, no solution remains greater than T for all time. Since $T > 3$ is arbitrary, no solution remains greater than 3 (by a fixed amount) for all time.

The same idea works to show that no solution can remain less than 3 (by a fixed amount) for all time. Hence, every solution tends to 3 as $t \rightarrow \infty$.

28. Since the equation is linear, we can consider the two separate differential equations

$$\frac{dy_1}{dt} + ay_1 = \cos 3t \quad \text{and} \quad \frac{dy_2}{dt} + ay_2 = b$$

(see Exercise 19 of Appendix A). One particular solution of the equation for y_1 is of the form

$$y_1(t) = \alpha \cos 3t + \beta \sin 3t,$$

and one particular solution of the equation for y_2 is the equilibrium solution $y_2(t) = b/a$. The solution $y_1(t)$ oscillates in a periodic fashion. In fact, we can use the techniques introduced in Section 4.4 to show that the amplitude of the oscillations is no larger than $1/3$.

The general solution of the associated homogeneous equation is $y_h(t) = ke^{-at}$, so the general solution of the original differential equation can be written as

$$y(t) = y_h(t) + y_1(t) + y_2(t).$$

As $t \rightarrow \infty$, $y_h(t) \rightarrow 0$, and therefore all solutions behave like the sum $y_1(t) + y_2(t)$ over the long term. In other words, they oscillate about $y = b/a$ with periodic oscillations of amplitude at most $1/3$.

29. (a) The differential equation modeling the problem is

$$\frac{dP}{dt} = .011P + 1,040,$$

where \$1,040 is the amount of money added to the account per year (assuming a “continuous deposit”).

- (b) To find the general solution, we first compute the general solution of the associated homogeneous equation. It is $P_h(t) = ke^{0.011t}$.

To find a particular solution of the nonhomogeneous equation, we observe that the equation is autonomous, and we calculate its equilibrium solution. It is $P(t) = -1,040/.011 \approx -94,545.46$ for all t . (This equilibrium solution is what we would have calculated if we had guessed a constant.)

Hence, the general solution is

$$P(t) = -94,545.46 + ke^{0.011t}.$$

Since the account initially has \$1,000 in it, the initial condition is $P(0) = 1,000$. Solving

$$1000 = -94,545.46 + ke^{0.011(0)}$$

yields $k = 95,545.46$. Therefore, our model is

$$P(t) = -94,545.46 + 95,545.46e^{0.011t}.$$

To find the amount on deposit after 5 years, we evaluate $P(5)$ and obtain

$$-94,545.46 + 95,545.46e^{0.011(5)} \approx 6,402.20.$$

30. Let $M(t)$ be the amount of money left at time t . Then, we have the initial condition $M(0) = \$70,000$. Money is being added to the account at a rate of 1.5% and removed from the account at a rate of \$30,000 per year, so

$$\frac{dM}{dt} = 0.015M - 30,000.$$

To find the general solution, we first compute the general solution of the associated homogeneous equation. It is $M_h(t) = ke^{0.015t}$.

To find a particular solution of the nonhomogeneous equation, we observe that the equation is autonomous, and we calculate its equilibrium solution. It is $M(t) = 30,000/.015 = \$2,000,000$ for all t . (This equilibrium solution is what we would have calculated if we had guessed a constant.)

Therefore we have

$$M(t) = 2,000,000 + ke^{0.015t}.$$

Using the initial condition $M(0) = 70,000$, we have

$$2,000,000 + k = 70,000,$$

so $k = -1,930,000$ and

$$M(t) = 2,000,000 - 1,930,000e^{0.015t}.$$

Solving for the value of t when $M(t) = 0$, we have

$$2,000,000 - 1,930,000e^{0.015t} = 0,$$

which is equivalent to

$$e^{0.015t} = \frac{2,000,000}{1,930,000}.$$

In other words,

$$0.015t = \ln(1.03627),$$

which yields $t \approx 2.375$ years.

31. Step 1: *Before retirement*

First we calculate how much money will be in her retirement fund after 30 years. The differential equation modeling the situation is

$$\frac{dy}{dt} = .07y + 5,000,$$

where $y(t)$ represents the fund's balance at time t .

The general solution of the homogeneous equation is $y_h(t) = ke^{0.07t}$.

To find a particular solution, we observe that the nonhomogeneous equation is autonomous and that it has an equilibrium solution at $y = -5,000/0.07 \approx -71,428.57$. We can use this equilibrium solution as the particular solution. (It is the solution we would have computed if we had guessed a constant solution). We obtain

$$y(t) = ke^{0.07t} - 71,428.57.$$

From the initial condition, we see that $k = 71,428.57$, and

$$y(t) = 71,428.57(e^{0.07t} - 1).$$

Letting $t = 30$, we compute that the fund contains $\approx \$511,869.27$ after 30 years.

Step 2: *After retirement*

We need a new model for the remaining years since the professor is withdrawing rather than depositing. Since she withdraws at a rate of \$3,000 per month (\$36,000 per year), we write

$$\frac{dy}{dt} = .07y - 36,000,$$

where we continue to measure time t in years.

Again, the solution of the homogeneous equation is $y_h(t) = ke^{0.07t}$.

To find a particular solution of the nonhomogeneous equation, we note that the equation is autonomous and that it has an equilibrium at $y = 36,000/0.07 \approx 514,285.71$. Hence, we may take the particular solution to be this equilibrium solution. (Again, this solution is what we would have computed if we had guessed a constant function for y_p .)

The general solution is

$$y(t) = ke^{0.07t} + 514,285.71.$$

In this case, we have the initial condition $y(0) = 511,869.27$ since now $y(t)$ is the amount in the fund t years after she retires. Solving $511,869.27 = k + 514,285.71$, we get $k = -2,416.44$. The solution in this case is

$$y(t) = -2,416.44e^{0.07t} + 514,285.71.$$

Finally, we wish to know when her money runs out. That is, at what time t is $y(t) = 0$? Solving

$$y(t) = -2,416.44e^{0.07t} + 514,285.71 = 0$$

yields $t \approx 76.58$ years (approximately 919 months).

32. Note that $dy/dt = 1/5$ for this function. Substituting $y(t) = t/5$ in the right-hand side of the differential equation yields

$$(\cos t) \left(\frac{t}{5} \right) + \frac{1}{5}(1 - t \cos t),$$

which also equals $1/5$. Hence, $y(t) = t/5$ is a solution.

33. (a) We know that

$$\frac{dy_h}{dt} = a(t)y_h \quad \text{and} \quad \frac{dy_p}{dt} = a(t)y_p + b(t).$$

Then

$$\begin{aligned} \frac{d(y_h + y_p)}{dt} &= a(t)y_h + a(t)y_p + b(t) \\ &= a(t)(y_h + y_p) + b(t). \end{aligned}$$

- (b) We know that

$$\frac{dy_p}{dt} = a(t)y_p + b(t) \quad \text{and} \quad \frac{dy_q}{dt} = a(t)y_q + b(t).$$

Then

$$\begin{aligned} \frac{d(y_p - y_q)}{dt} &= (a(t)y_p + b(t)) - (a(t)y_q + b(t)) \\ &= a(t)(y_p - y_q). \end{aligned}$$

34. Suppose k is a constant and $y_1(t)$ is a solution. Then we know that $ky_1(t)$ is also a solution. Hence,

$$\frac{d(ky_1)}{dt} = f(t, ky_1)$$

for all t . Also,

$$\frac{d(ky_1)}{dt} = k \frac{dy_1}{dt} = kf(t, y_1)$$

because $y_1(t)$ is a solution. Therefore, we have

$$f(t, ky_1) = kf(t, y_1)$$

for all t . In particular, if $y_1(t) \neq 0$, we can pick $k = 1/y_1(t)$, and we get

$$f(t, 1) = \frac{1}{y_1(t)} f(t, y_1(t)).$$

In other words,

$$y_1(t)f(t, 1) = f(t, y_1(t))$$

for all t for which $y_1(t) \neq 0$. If we ignore the dependence on t , we have

$$yf(t, 1) = f(t, y)$$

for all $y \neq 0$ because we know that there is a solution $y_1(t)$ that solves the initial-value problem $y_1(t) = y$. By continuity, we know that the equality

$$yf(t, 1) = f(t, y)$$

holds even as y tends to zero.

If we define $a(t) = f(t, 1)$, we have

$$f(t, y) = a(t)y.$$

The differential equation is linear and homogeneous.

EXERCISES FOR SECTION 1.9

1. We rewrite the equation in the form

$$\frac{dy}{dt} + \frac{y}{t} = 2$$

and note that the integrating factor is

$$\mu(t) = e^{\int (1/t) dt} = e^{\ln t} = t.$$

Multiplying both sides by $\mu(t)$, we obtain

$$t \frac{dy}{dt} + y = 2t.$$

Applying the Product Rule to the left-hand side, we see that this equation is the same as

$$\frac{d(ty)}{dt} = 2t,$$

and integrating both sides with respect to t , we obtain

$$ty = t^2 + c,$$

where c is an arbitrary constant. The general solution is

$$y(t) = \frac{1}{t}(t^2 + c) = t + \frac{c}{t}.$$

2. We rewrite the equation in the form

$$\frac{dy}{dt} - \frac{3}{t}y = t^5$$

and note that the integrating factor is

$$\mu(t) = e^{\int (-3/t) dt} = e^{-3 \ln t} = e^{\ln(t^{-3})} = t^{-3}.$$

Multiplying both sides by $\mu(t)$, we obtain

$$t^{-3} \frac{dy}{dt} - 3t^{-4}y = t^2.$$

Applying the Product Rule to the left-hand side, we see that this equation is the same as

$$\frac{d(t^{-3}y)}{dt} = t^2$$

and integrating both sides with respect to t , we obtain

$$t^{-3}y = \frac{t^3}{3} + c,$$

where c is an arbitrary constant. The general solution is

$$y(t) = \frac{t^6}{3} + ct^3.$$

3. We rewrite the equation in the form

$$\frac{dy}{dt} + \frac{y}{1+t} = t^2$$

and note that the integrating factor is

$$\mu(t) = e^{\int (1/(1+t)) dt} = e^{\ln(1+t)} = 1+t.$$

Multiplying both sides by $\mu(t)$, we obtain

$$(1+t)\frac{dy}{dt} + y = (1+t)t^2.$$

Applying the Product Rule to the left-hand side, we see that this equation is the same as

$$\frac{d((1+t)y)}{dt} = t^3 + t^2,$$

and integrating both sides with respect to t , we obtain

$$(1+t)y = \frac{t^4}{4} + \frac{t^3}{3} + c,$$

where c is an arbitrary constant. The general solution is

$$y(t) = \frac{3t^4 + 4t^3 + 12c}{12(t+1)}.$$

4. We rewrite the equation in the form

$$\frac{dy}{dt} + 2ty = 4e^{-t^2}$$

and note that the integrating factor is

$$\mu(t) = e^{\int 2t dt} = e^{t^2}.$$

Multiplying both sides by $\mu(t)$, we obtain

$$e^{t^2} \frac{dy}{dt} + 2te^{t^2} y = 4.$$

Applying the Product Rule to the left-hand side, we see that this equation is the same as

$$\frac{d(e^{t^2} y)}{dt} = 4,$$

and integrating both sides with respect to t , we obtain

$$e^{t^2} y = 4t + c,$$

where c is an arbitrary constant. The general solution is

$$y(t) = 4te^{-t^2} + ce^{-t^2}.$$

5. Note that the integrating factor is

$$\mu(t) = e^{\int (-2t/(1+t^2)) dt} = e^{-\ln(1+t^2)} = \left(e^{\ln(1+t^2)}\right)^{-1} = \frac{1}{1+t^2}.$$

Multiplying both sides by $\mu(t)$, we obtain

$$\frac{1}{1+t^2} \frac{dy}{dt} - \frac{2t}{(1+t^2)^2} y = \frac{3}{1+t^2}.$$

Applying the Product Rule to the left-hand side, we see that this equation is the same as

$$\frac{d}{dt} \left(\frac{y}{1+t^2} \right) = \frac{3}{1+t^2}.$$

Integrating both sides with respect to t , we obtain

$$\frac{y}{1+t^2} = 3 \arctan(t) + c,$$

where c is an arbitrary constant. The general solution is

$$y(t) = (1+t^2)(3 \arctan(t) + c).$$

6. Note that the integrating factor is

$$\mu(t) = e^{\int (-2/t) dt} = e^{-2 \ln t} = e^{\ln(t^{-2})} = t^{-2}.$$

Multiplying both sides by $\mu(t)$, we obtain

$$t^{-2} \frac{dy}{dt} - 2t^{-3} y = te^t.$$

Applying the Product Rule to the left-hand side, we see that this equation is the same as

$$\frac{d(t^{-2}y)}{dt} = te^t,$$

and integrating both sides with respect to t , we obtain

$$t^{-2}y = (t - 1)e^t + c,$$

where c is an arbitrary constant. The general solution is

$$y(t) = t^2(t - 1)e^t + ct^2.$$

7. We rewrite the equation in the form

$$\frac{dy}{dt} + \frac{y}{1+t} = 2$$

and note that the integrating factor is

$$\mu(t) = e^{\int(1/(1+t))dt} = e^{\ln(1+t)} = 1 + t.$$

Multiplying both sides by $\mu(t)$, we obtain

$$(1+t)\frac{dy}{dt} + y = 2(1+t).$$

Applying the Product Rule to the left-hand side, we see that this equation is the same as

$$\frac{d((1+t)y)}{dt} = 2(1+t),$$

and integrating both sides with respect to t , we obtain

$$(1+t)y = 2t + t^2 + c,$$

where c is an arbitrary constant. The general solution is

$$y(t) = \frac{t^2 + 2t + c}{1+t}.$$

To find the solution that satisfies the initial condition $y(0) = 3$, we evaluate the general solution at $t = 0$ and obtain

$$c = 3.$$

The desired solution is

$$y(t) = \frac{t^2 + 2t + 3}{1+t}.$$

8. We rewrite the equation in the form

$$\frac{dy}{dt} - \frac{1}{t+1}y = 4t^2 + 4t$$

and note that the integrating factor is

$$\mu(t) = e^{\int (-1/(t+1)) dt} = e^{-\ln(t+1)} = \left(e^{\ln((t+1)^{-1})} \right) = \frac{1}{t+1}.$$

Multiplying both sides by $\mu(t)$, we obtain

$$\frac{1}{t+1} \frac{dy}{dt} - \frac{1}{(t+1)^2} y = \frac{4t^2 + 4t}{t+1}.$$

Applying the Product Rule to the left-hand side, we see that this equation is the same as

$$\frac{d}{dt} \left(\frac{y}{t+1} \right) = 4t.$$

Integrating both sides with respect to t , we obtain

$$\frac{y}{t+1} = 2t^2 + c,$$

where c is an arbitrary constant. The general solution is

$$y(t) = (2t^2 + c)(t+1) = 2t^3 + 2t^2 + ct + c.$$

To find the solution that satisfies the initial condition $y(1) = 10$, we evaluate the general solution at $t = 1$ and obtain $c = 3$. The desired solution is

$$y(t) = 2t^3 + 2t^2 + 3t + 3.$$

9. In Exercise 1, we derived the general solution

$$y(t) = t + \frac{c}{t}.$$

To find the solution that satisfies the initial condition $y(1) = 3$, we evaluate the general solution at $t = 1$ and obtain $c = 2$. The desired solution is

$$y(t) = t + \frac{2}{t}.$$

10. In Exercise 4, we derived the general solution

$$y(t) = 4te^{-t^2} + ce^{-t^2}.$$

To find the solution that satisfies the initial condition $y(0) = 3$, we evaluate the general solution at $t = 0$ and obtain $c = 3$. The desired solution is

$$y(t) = 4te^{-t^2} + 3e^{-t^2}.$$

11. Note that the integrating factor is

$$\mu(t) = e^{\int -(2/t) dt} = e^{-2 \int (1/t) dt} = e^{-2 \ln t} = e^{\ln(t^{-2})} = \frac{1}{t^2}.$$

Multiplying both sides by $\mu(t)$, we obtain

$$\frac{1}{t^2} \frac{dy}{dt} - \frac{2y}{t^3} = 2.$$

Applying the Product Rule to the left-hand side, we see that this equation is the same as

$$\frac{d}{dt} \left(\frac{y}{t^2} \right) = 2,$$

and integrating both sides with respect to t , we obtain

$$\frac{y}{t^2} = 2t + c,$$

where c is an arbitrary constant. The general solution is

$$y(t) = 2t^3 + ct^2.$$

To find the solution that satisfies the initial condition $y(-2) = 4$, we evaluate the general solution at $t = -2$ and obtain

$$-16 + 4c = 4.$$

Hence, $c = 5$, and the desired solution is

$$y(t) = 2t^3 + 5t^2.$$

12. Note that the integrating factor is

$$\mu(t) = e^{\int (-3/t) dt} = e^{-3 \ln t} = e^{\ln(t^{-3})} = t^{-3}.$$

Multiplying both sides by $\mu(t)$, we obtain

$$t^{-3} \frac{dy}{dt} - 3t^{-4}y = 2e^{2t}.$$

Applying the Product Rule to the left-hand side, we see that this equation is the same as

$$\frac{d(t^{-3}y)}{dt} = 2e^{2t},$$

and integrating both sides with respect to t , we obtain

$$t^{-3}y = e^{2t} + c,$$

where c is an arbitrary constant. The general solution is

$$y(t) = t^3(e^{2t} + c).$$

To find the solution that satisfies the initial condition $y(1) = 0$, we evaluate the general solution at $t = 1$ and obtain $c = -e^2$. The desired solution is

$$y(t) = t^3(e^{2t} - e^2).$$

13. We rewrite the equation in the form

$$\frac{dy}{dt} - (\sin t)y = 4$$

and note that the integrating factor is

$$\mu(t) = e^{\int(-\sin t) dt} = e^{\cos t}.$$

Multiplying both sides by $\mu(t)$, we obtain

$$e^{\cos t} \frac{dy}{dt} - e^{\cos t} (\sin t)y = 4e^{\cos t}.$$

Applying the Product Rule to the left-hand side, we see that this equation is the same as

$$\frac{d(e^{\cos t} y)}{dt} = 4e^{\cos t},$$

and integrating both sides with respect to t , we obtain

$$e^{\cos t} y = \int 4e^{\cos t} dt.$$

Since the integral on the right-hand side is impossible to express using elementary functions, we write the general solution as

$$y(t) = 4e^{-\cos t} \int e^{\cos t} dt.$$

14. We rewrite the equation in the form

$$\frac{dy}{dt} - t^2 y = 4$$

and note that the integrating factor is

$$\mu(t) = e^{\int(-t^2) dt} = e^{-t^3/3}.$$

Multiplying both sides of the equation by $\mu(t)$, we obtain

$$e^{-t^3/3} \frac{dy}{dt} - t^2 e^{-t^3/3} y = 4e^{-t^3/3}.$$

Applying the Product Rule to the left-hand side, we see that this equation is the same as

$$\frac{d(e^{-t^3/3} y)}{dt} = 4e^{-t^3/3},$$

and integrating both sides with respect to t , we obtain

$$e^{-t^3/3} y = \int 4e^{-t^3/3} dt.$$

Since the integral on the right-hand side is impossible to express using elementary functions, we write the general solution as

$$y(t) = 4e^{t^3/3} \int e^{-t^3/3} dt.$$

15. We rewrite the equation in the form

$$\frac{dy}{dt} - \frac{y}{t^2} = 4 \cos t$$

and note that the integrating factor is

$$\mu(t) = e^{\int (-1/t^2) dt} = e^{1/t}.$$

Multiplying both sides by $\mu(t)$, we obtain

$$e^{1/t} \frac{dy}{dt} - \frac{e^{1/t}}{t^2} y = 4e^{1/t} \cos t.$$

Applying the Product Rule to the left-hand side, we see that this equation is the same as

$$\frac{d(e^{1/t} y)}{dt} = 4e^{1/t} \cos t,$$

and integrating both sides with respect to t , we obtain

$$e^{1/t} y = \int 4e^{1/t} \cos t dt.$$

Since the integral on the right-hand side is impossible to express using elementary functions, we write the general solution as

$$y(t) = 4e^{-1/t} \int e^{1/t} \cos t dt.$$

16. We rewrite the equation in the form

$$\frac{dy}{dt} - y = 4 \cos t^2$$

and note that the integrating factor is

$$\mu(t) = e^{\int -1 dt} = e^{-t}.$$

Multiplying both sides of the equation by $\mu(t)$, we obtain

$$e^{-t} \frac{dy}{dt} - e^{-t} y = 4e^{-t} \cos t^2.$$

Applying the Product Rule to the left-hand side, we see that this equation is the same as

$$\frac{d(e^{-t} y)}{dt} = 4e^{-t} \cos t^2,$$

and integrating both sides with respect to t , we obtain

$$e^{-t} y = \int 4e^{-t} \cos t^2 dt.$$

Since the integral on the right-hand side is impossible to express using elementary functions, we write the general solution as

$$y(t) = 4e^t \int e^{-t} \cos t^2 dt.$$

17. We rewrite the equation in the form

$$\frac{dy}{dt} + e^{-t^2} y = \cos t$$

and note that the integrating factor is

$$\mu(t) = e^{\int e^{-t^2} dt}.$$

This integral is impossible to express in terms of elementary functions. Multiplying both sides by $\mu(t)$, we obtain

$$\left(e^{\int e^{-t^2} dt} \right) \frac{dy}{dt} + \left(e^{\int e^{-t^2} dt} \right) e^{-t^2} y = \left(e^{\int e^{-t^2} dt} \right) \cos t.$$

Applying the Product Rule to the left-hand side, we see that this equation is the same as

$$\frac{d \left(\left(e^{\int e^{-t^2} dt} \right) y \right)}{dt} = \left(e^{\int e^{-t^2} dt} \right) \cos t,$$

and integrating both sides with respect to t , we obtain

$$\left(e^{\int e^{-t^2} dt} \right) y = \int \left(e^{\int e^{-t^2} dt} \right) \cos t dt.$$

These integrals are also impossible to express in terms of elementary functions, so we write the general solution in the form

$$y(t) = \left(e^{-\int e^{-t^2} dt} \right) \int \left(e^{\int e^{-t^2} dt} \right) \cos t dt.$$

18. We rewrite the equation in the form

$$\frac{dy}{dt} - \frac{y}{\sqrt{t^3-3}} = t$$

and note that the integrating factor is

$$\mu(t) = e^{-\int \frac{1}{\sqrt{t^3-3}} dt}.$$

This integral is impossible to express in terms of elementary functions. Multiplying both sides by $\mu(t)$, we obtain

$$\left(e^{-\int \frac{1}{\sqrt{t^3-3}} dt} \right) \frac{dy}{dt} - \left(e^{-\int \frac{1}{\sqrt{t^3-3}} dt} \right) \frac{y}{\sqrt{t^3-3}} = t \left(e^{-\int \frac{1}{\sqrt{t^3-3}} dt} \right).$$

Applying the Product Rule to the left-hand side, we see that this equation is the same as

$$\frac{d \left(\left(e^{-\int \frac{1}{\sqrt{t^3-3}} dt} \right) y \right)}{dt} = t \left(e^{-\int \frac{1}{\sqrt{t^3-3}} dt} \right),$$

and integrating both sides with respect to t , we obtain

$$\left(e^{-\int \frac{1}{\sqrt{t^3-3}} dt} \right) y = \int t \left(e^{-\int \frac{1}{\sqrt{t^3-3}} dt} \right) dt.$$

These integrals are also impossible to express in terms of elementary functions, so we write the general solution in the form

$$y(t) = \left(e^{\int \frac{1}{\sqrt{t^3-3}} dt} \right) \int t \left(e^{-\int \frac{1}{\sqrt{t^3-3}} dt} \right) dt.$$

19. We rewrite the equation in the form

$$\frac{dy}{dt} - aty = 4e^{-t^2}$$

and note that the integrating factor is

$$\mu(t) = e^{\int (-at) dt} = e^{-at^2/2}.$$

Multiplying both sides by $\mu(t)$, we obtain

$$e^{-at^2/2} \frac{dy}{dt} - ate^{-at^2/2}y = 4e^{-t^2}e^{-at^2/2}.$$

Applying the Product Rule to the left-hand side and simplifying the right-hand side, we see that this equation is the same as

$$\frac{d(e^{-at^2/2}y)}{dt} = 4e^{-(1+a/2)t^2}.$$

Integrating both sides with respect to t , we obtain

$$e^{-at^2/2}y = \int 4e^{-(1+a/2)t^2} dt.$$

The integral on the right-hand side can be expressed in terms of elementary functions only if $1 + a/2 = 0$ (that is, if the factor involving e^{t^2} really isn't there). Hence, the only value of a that yields an integral we can express in terms of elementary functions form is $a = -2$ (see Exercise 4).

20. We rewrite the equation in the form

$$\frac{dy}{dt} - t^r y = 4$$

and note that the integrating factor is

$$\mu(t) = e^{-\int t^r dt}.$$

There are two cases to consider.

(a) If $r \neq -1$, then

$$\mu(t) = e^{-t^{r+1}/(r+1)}.$$

Multiplying both sides of the differential equation by $\mu(t)$, we obtain

$$\left(e^{-t^{r+1}/(r+1)} \right) \frac{dy}{dt} - t^r \left(e^{-t^{r+1}/(r+1)} \right) y = 4 \left(e^{-t^{r+1}/(r+1)} \right).$$

Applying the Product Rule to the left-hand side, we see that this equation is the same as

$$\frac{d\left(\left(e^{-t^{r+1}/(r+1)}\right) y\right)}{dt} = 4\left(e^{-t^{r+1}/(r+1)}\right).$$

The next step is to integrate both sides with respect to t . The integral

$$\int 4\left(e^{-t^{r+1}/(r+1)}\right) dt$$

on the right-hand side can only be expressed in terms of elementary functions if $r = 0$.

(b) If $r = -1$, then the integrating factor is

$$\mu(t) = e^{-\int t^{-1} dt} = e^{-\ln t} = \frac{1}{t}.$$

Multiplying both sides by $\mu(t)$ yields the equation

$$\frac{d(t^{-1} y)}{dt} = \frac{4}{t},$$

and since $\int (4/t) dt = 4 \ln t$, we can express the solution without integrals in this case.

Hence, the values of r that give solutions in terms of elementary functions are $r = 0$ and $r = -1$.

21. (a) The integrating factor is

$$\mu(t) = e^{0.4t}.$$

Multiplying both sides of the differential equation by $\mu(t)$ and collecting terms, we obtain

$$\frac{d(e^{0.4t} v)}{dt} = 3e^{0.4t} \cos 2t.$$

Integrating both sides with respect to t yields

$$e^{0.4t} v = \int 3e^{0.4t} \cos 2t dt.$$

To calculate the integral on the right-hand side, we must integrate by parts twice.

For the first integration, we pick $u_1(t) = \cos 2t$ and $v_1(t) = e^{0.4t}$. Using the fact that $0.4 = 2/5$, we get

$$\int e^{0.4t} \cos 2t dt = \frac{5}{2} e^{0.4t} \cos 2t + 5 \int e^{0.4t} \sin 2t dt.$$

For the second integration, we pick $u_2(t) = \sin 2t$ and $v_2(t) = e^{0.4t}$. We get

$$\int e^{0.4t} \sin 2t dt = \frac{5}{2} e^{0.4t} \sin 2t - 5 \int e^{0.4t} \cos 2t dt.$$

Combining these results yields

$$\int e^{0.4t} \cos 2t dt = \frac{5}{2} e^{0.4t} \cos 2t + \frac{25}{2} e^{0.4t} \sin 2t - 25 \int e^{0.4t} \cos 2t dt.$$

Solving for $\int e^{0.4t} \cos 2t \, dt$, we have

$$\int e^{0.4t} \cos 2t \, dt = \frac{5 e^{0.4t} \cos 2t + 25 e^{0.4t} \sin 2t}{52}.$$

To obtain the general solution, we multiply this integral by 3, add the constant of integration, and solve for v . We obtain the general solution

$$v(t) = k e^{-0.4t} + \frac{15}{52} \cos 2t + \frac{75}{52} \sin 2t.$$

(b) The solution of the associated homogeneous equation is

$$v_h(t) = e^{-0.4t}.$$

We guess

$$v_p(t) = \alpha \cos 2t + \beta \sin 2t$$

for the a solution to the nonhomogeneous equation and solve for α and β . Substituting this guess into the differential equation, we obtain

$$-2\alpha \sin 2t + 2\beta \cos 2t + 0.4\alpha \cos 2t + 0.4\beta \sin 2t = 3 \cos 2t.$$

Collecting sine and cosine terms, we get the system of equations

$$\begin{cases} -2\alpha + 0.4\beta = 0 \\ 0.4\alpha + 2\beta = 3. \end{cases}$$

Using the fact that $0.4 = 2/5$, we solve this system of equations and obtain

$$\alpha = \frac{15}{52} \quad \text{and} \quad \beta = \frac{75}{52}.$$

The general solution of the original nonhomogeneous equation is

$$v(t) = k e^{-0.4t} + \frac{15}{52} \cos 2t + \frac{75}{52} \sin 2t.$$

Both methods require quite a bit of computation. If we use an integrating factor, we must do a complicated integral, and if we use the guessing technique, we have to be careful with our algebra.

22. (a) Note that

$$\frac{d\mu}{dt} = \mu(t)(-a(t))$$

by the Fundamental Theorem of Calculus. Therefore, if we rewrite the differential equation as

$$\frac{dy}{dt} - a(t)y = b(t)$$

and multiply the left-hand side of this equation by $\mu(t)$, the left-hand side becomes

$$\begin{aligned} \mu(t) \frac{dy}{dt} - \mu(t)a(t)y &= \mu(t) \frac{dy}{dt} + \frac{d\mu}{dt} y \\ &= \frac{d(\mu y)}{dt}. \end{aligned}$$

Consequently, the function $\mu(t)$ satisfies the requirements of an integrating factor.

(b) To see that $1/\mu(t)$ is a solution of the associated homogeneous equation, we calculate

$$\begin{aligned}\frac{d\left(\frac{1}{\mu(t)}\right)}{dt} &= \frac{-1}{\mu(t)^2} \frac{d\mu}{dt} \\ &= \frac{-1}{\mu(t)^2} \mu(t)(-a(t)) \\ &= a(t) \frac{1}{\mu(t)}.\end{aligned}$$

Thus, $y(t) = 1/\mu(t)$ satisfies the equation $dy/dt = a(t)y$.

(c) To see that $y_p(t)$ is a solution to the nonhomogeneous equation, we compute

$$\begin{aligned}\frac{dy_p}{dt} &= \frac{d\left(\frac{1}{\mu(t)}\right)}{dt} \left(\int_0^t \mu(\tau) b(\tau) d\tau\right) + \frac{1}{\mu(t)} \mu(t) b(t) \\ &= a(t) \frac{1}{\mu(t)} \left(\int_0^t \mu(\tau) b(\tau) d\tau\right) + b(t) \\ &= a(t)y_p(t) + b(t).\end{aligned}$$

(d) Let k be an arbitrary constant. Since $k/\mu(t)$ is the general solution of the associated homogeneous equation and

$$\frac{1}{\mu(t)} \int_0^t \mu(\tau) b(\tau) d\tau$$

is a solution to the nonhomogeneous equation, the general solution of the nonhomogeneous equation is

$$\begin{aligned}y(t) &= \frac{k}{\mu(t)} + \frac{1}{\mu(t)} \int_0^t \mu(\tau) b(\tau) d\tau \\ &= \frac{1}{\mu(t)} \left(k + \int_0^t \mu(\tau) b(\tau) d\tau\right).\end{aligned}$$

(e) Since

$$\int \mu(t) b(t) dt = \int_0^t \mu(\tau) b(\tau) d\tau + k$$

by the Fundamental Theorem of Calculus, the two formulas agree.

(f) In this equation, $a(t) = -2t$ and $b(t) = 4e^{-t^2}$. Therefore,

$$\mu(t) = e^{\int_0^t 2\tau d\tau} = e^{t^2}.$$

Consequently, $1/\mu(t) = e^{-t^2}$. Note that,

$$\frac{d\left(\frac{1}{\mu(t)}\right)}{dt} = (-2t)e^{-t^2} = a(t) \frac{1}{\mu(t)}.$$

Also,

$$y_p(t) = e^{-t^2} \int_0^t e^{\tau^2} (4e^{-\tau^2}) d\tau = e^{-t^2} \int_0^t 4 d\tau = 4te^{-t^2}.$$

It is easy to see that $4te^{-t^2}$ satisfies the nonhomogeneous equation.

Therefore, the general solution to the nonhomogeneous equation is

$$ke^{-t^2} + 4te^{-t^2},$$

which can also be written as $(4t + k)e^{-t^2}$. Finally, note that

$$\frac{1}{\mu(t)} \int \mu(t) b(t) dt = e^{-t^2} \int e^{t^2} (4e^{-t^2}) dt = (4t + k)e^{-t^2}.$$

23. The integrating factor is

$$\mu(t) = e^{\int 2 dt} = e^{2t}.$$

Multiplying both sides by $\mu(t)$, we obtain

$$\begin{aligned} e^{2t} \frac{dy}{dt} + 2e^{2t} y &= 3e^{2t} e^{-2t} \\ &= 3. \end{aligned}$$

Applying the Product Rule to the left-hand side, we see that this equation is the same as

$$\frac{d(e^{2t} y)}{dt} = 3,$$

and integrating both sides with respect to t , we obtain

$$e^{2t} y = 3t + k,$$

where k is an arbitrary constant. The general solution is

$$y(t) = (3t + k)e^{-2t}.$$

We know that ke^{-2t} is the general solution of the associated homogeneous equation, so $y_p(t) = 3te^{-2t}$ is a particular solution of the nonhomogeneous equation. Note that the factor of t arose after we multiplied the right-hand side of the equation by the integrating factor and ended up with the constant 3. After integrating, the constant produces a factor of t .

24. Let $S(t)$ be the amount of salt (in pounds) in the tank at time t . Then noting the amounts of salt that enter and leave the tank per minute, we have

$$\frac{dS}{dt} = 2 - \frac{S}{V(t)},$$

where $V(t)$ is the volume of the tank at time t . We have $V(t) = 15 + t$ since the tank starts with 15 gallons and one gallon per minute more is pumped into the tank than leaves the tank. So

$$\frac{dS}{dt} = 2 - \frac{S}{15 + t}.$$

This equation is linear, and we can rewrite it as

$$\frac{dS}{dt} + \frac{S}{15+t} = 2.$$

The integrating factor is

$$\mu(t) = e^{\int 1/(15+t) dt} = e^{\ln(15+t)} = 15+t.$$

Multiplying both sides of the equation by $\mu(t)$, we obtain

$$(15+t)\frac{dS}{dt} + S = 2(15+t),$$

which via the Product Rule is equivalent to

$$\frac{d((15+t)S)}{dt} = 30 + 2t.$$

Integration and simplification yields

$$S(t) = \frac{t^2 + 30t + c}{15+t}.$$

Using the initial condition $S(0) = 6$, we have $c/15 = 6$, which implies that $c = 90$ and

$$S(t) = \frac{t^2 + 30t + 90}{15+t}.$$

The tank is full when $t = 15$, and the amount of salt at that time is $S(15) = 51/2$ pounds.

- 25.** We will use the term “parts” as shorthand for the product of parts per billion of dioxin and the volume of water in the tank. Basically this product represents the total amount of dioxin in the tank. The tank initially contains 200 gallons at a concentration of 2 parts per billion, which results in 400 parts of dioxin.

Let $y(t)$ be the amount of dioxin in the tank at time t . Since water with 4 parts per billion of dioxin flows in at the rate of 5 gallons per minute, 20 parts of dioxin enter the tank each minute. Also, the volume of water in the tank at time t is $200 + 2t$, so the concentration of dioxin in the tank is $y/(200 + 2t)$. Since well-mixed water leaves the tank at the rate of 2 gallons per minute, the differential equation that represents the change in the amount of dioxin in the tank is

$$\frac{dy}{dt} = 20 - 2\left(\frac{y}{200+2t}\right),$$

which can be simplified and rewritten as

$$\frac{dy}{dt} + \left(\frac{1}{100+t}\right)y = 20.$$

The integrating factor is

$$\mu(t) = e^{\int 1/(100+t) dt} = e^{\ln(100+t)} = 100+t.$$

Multiplying both sides by $\mu(t)$, we obtain

$$(100 + t) \frac{dy}{dt} + y = 20(100 + t),$$

which is equivalent to

$$\frac{d((100 + t)y)}{dt} = 20(100 + t)$$

by the Product Rule. Integrating both sides with respect to t , we obtain

$$(100 + t)y = 2000t + 10t^2 + c.$$

Since $y(0) = 400$, we see that $c = 40,000$. Therefore,

$$y(t) = \frac{10t^2 + 2000t + 40,000}{t + 100}.$$

The tank fills up at $t = 100$, and $y(100) = 1,700$. To express our answer in terms of concentration, we calculate $y(100)/400 = 4.25$ parts per billion.

- 26.** Let $S(t)$ denote the amount of sugar in the tank at time t . Sugar is added to the tank at the rate of p pounds per minute. The amount of sugar that leaves the tank is the product of the concentration of the sugar in the water and the rate that the water leaves the tank. At time t , there are $100 - t$ gallons of sugar water in the tank, so the concentration of sugar is $S(t)/(100 - t)$. Since sugar water leaves the tank at the rate of 1 gallon per minute, the differential equation for S is

$$\frac{dS}{dt} = p - \frac{S}{100 - t}.$$

Since this equation is linear, we rewrite it as

$$\frac{dS}{dt} + \frac{S}{100 - t} = p,$$

and the integrating factor is

$$\mu(t) = e^{\int (1/(100-t)) dt} = e^{-\ln(100-t)} = \frac{1}{100 - t}.$$

Multiplying both sides of the differential equation by $\mu(t)$ yields

$$\left(\frac{1}{100 - t} \right) \frac{dS}{dt} + \frac{S}{(100 - t)^2} = \frac{p}{100 - t},$$

which is equivalent to

$$\frac{d}{dt} \left(\frac{S}{100 - t} \right) = \frac{p}{100 - t}$$

by the Product Rule. We integrate both sides and obtain

$$\frac{S}{100 - t} = -p \ln(100 - t) + c,$$

where c is some constant. Note that the left-hand side of this formula is the concentration of sugar in the tank at time t .

At $t = 0$, the concentration of sugar is 0.25 pounds per gallon, so we can determine c by evaluating at $t = 0$. We obtain

$$0.25 = -p \ln(100) + c,$$

so

$$\begin{aligned} \frac{S}{100-t} &= -p \ln(100-t) + 0.25 + p \ln(100) \\ &= 0.25 + p \ln\left(\frac{100}{100-t}\right). \end{aligned}$$

- (a) To determine the value of p such that the concentration is 0.5 when there are 5 gallons left in the tank, we note that $t = 95$. We get

$$0.5 = 0.25 + p \ln 20,$$

so $p = 0.25/(\ln 20) \approx 0.08345$.

- (b) We can rephrase the question: Can we find p such that

$$\lim_{t \rightarrow 100^-} \frac{S}{100-t} = 0.75?$$

Using the formula for the concentration $S/(100-t)$, we have

$$\lim_{t \rightarrow 100^-} \frac{S}{100-t} = 0.25 + p \lim_{t \rightarrow 100^-} \ln\left(\frac{100}{100-t}\right).$$

As $t \rightarrow 100^-$, $100-t \rightarrow 0^+$, so

$$\lim_{t \rightarrow 100^-} \ln\left(\frac{100}{100-t}\right) = \infty.$$

If $p \neq 0$, then the concentration is unbounded as $t \rightarrow 100^-$. If $p = 0$, then the concentration is constant at 0.25. Hence it is impossible to choose p so that the “last” drop out of the bucket has a concentration of 0.75 pounds per gallon.

27. (a) Let $y(t)$ be the amount of salt in the tank at time t . Since the tank is being filled at a total rate of 1 gallon per minute, the volume at time t is $V_0 + t$ and the concentration of salt in the tank is

$$\frac{y}{V_0 + t}.$$

The amount of salt entering the tank is the product of 2 gallons per minute and 0.25 pounds of salt per minute. The amount of salt leaving the tank is the product of the concentration of salt in the tank and the rate that brine is leaving. In this case, the rate is 1 gallon per minute, so the amount of salt leaving the tank is $y/(V_0 + t)$. The differential equation for $y(t)$ is

$$\frac{dy}{dt} = \frac{1}{2} - \frac{y}{V_0 + t}.$$

Since the water is initially clean, the initial condition is $y(0) = 0$.

(b) If $V_0 = 0$, the differential equation above becomes

$$\frac{dy}{dt} = \frac{1}{2} - \frac{y}{t}.$$

Note that this differential equation is undefined at $t = 0$. Thus, we *cannot* apply the Existence and Uniqueness Theorem to guarantee a unique solution at time $t = 0$. However, we can still solve the equation using our standard techniques assuming that $t \neq 0$.

Rewriting the equation as

$$\frac{dy}{dt} + \frac{y}{t} = \frac{1}{2},$$

we see that the integrating factor is

$$\mu(t) = e^{\int (1/t) dt} = e^{\ln t} = t.$$

Multiplying both sides of the differential equation by $\mu(t)$, we obtain

$$t \frac{dy}{dt} + y = \frac{t}{2},$$

which is equivalent to

$$\frac{d(ty)}{dt} = \frac{t}{2}.$$

Integrating both sides with respect to t , we get

$$ty = \frac{t^2}{4} + c,$$

so that the general solution is

$$y(t) = \frac{t}{4} + \frac{c}{t}.$$

Since the above expression is undefined at $t = 0$, we cannot make use of the initial condition $y(0) = 0$ to find the desired solution.

However, if the tank is initially empty, the concentration of salt in the tank remains constant over time at 0.25 pounds of salt per gallon. Therefore, we reconsider the equation

$$\frac{y}{t} = \frac{1}{4} + \frac{c}{t^2}.$$

If $c = 0$, we have $y/t = 1/4$. Hence, $c = 0$ yields the solution $y(t) = t/4$ which is a valid model for this situation.

It is useful to note that, if $V_0 = 0$, then we do not really need a differential equation to model the amount of the salt in the tank as a function of time. Clearly the concentration is constant as a function of time, and therefore the amount of salt in the tank is the product of the concentration and the volume of brine in the tank.

REVIEW EXERCISES FOR CHAPTER 1

1. The simplest differential equation with $y(t) = 2t$ as a solution is $dy/dt = 2$. The initial condition $y(0) = 3$ specifies the desired solution.

2. By guessing or separating variables, we know that the general solution is $y(t) = y_0 e^{3t}$, where $y(0) = y_0$ is the initial condition.
3. There are no values of y for which dy/dt is zero for all t . Hence, there are no equilibrium solutions.
4. Since the question only asks for one solution, look for the simplest first. Note that $y(t) = 0$ for all t is an equilibrium solution. There are other equilibrium solutions as well.
5. The right-hand side is zero for all t only if $y = -1$. Consequently, the function $y(t) = -1$ for all t is the only equilibrium solution.
6. The equilibria occur at $y = \pm n\pi$ for $n = 0, 1, 2, \dots$, and dy/dt is positive otherwise. So all of the arrows between the equilibrium points point up.

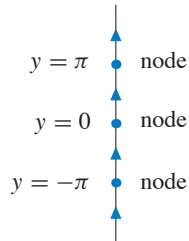

7. The equations $dy/dt = y$ and $dy/dt = 0$ are first-order, autonomous, separable, linear, and homogeneous.
8. The equation $dy/dt = y - 2$ is autonomous, linear, and nonhomogeneous. Moreover, if $y = 2$, then $dy/dt = 0$ for all t .
9. The graph of $f(y)$ must cross the y -axis from negative to positive at $y = 0$. For example, the graph of the function $f(y) = y$ produces this phase line.

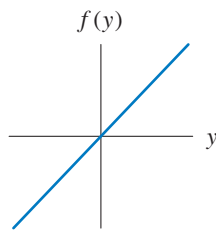

10. For $a > -4$, all solutions increase at a constant rate, and for $a < -4$, all solutions decrease at a constant rate. Consequently, a bifurcation occurs at $a = -4$, and all solutions are equilibria.
11. True. We have $dy/dt = e^{-t}$, which agrees with $|y(t)|$.
12. False. A separable equation has the form $dy/dt = g(t)h(y)$. So if $g(t)$ is not constant, then the equation is not separable. For example, $dy/dt = ty$ is separable but not autonomous.

13. True. Autonomous equations have the form $dy/dt = f(y)$. Therefore, we can separate variables by dividing by $f(y)$. That is,

$$\frac{1}{f(y)} \frac{dy}{dt} = 1.$$

14. False. For example, $dy/dt = y + t$ is linear but not separable.

15. False. For example, $dy/dt = ty^2$ is separable but not linear.

16. True. A homogeneous linear equation has the form $dy/dt = a(t)y$. We can separate variables by dividing by y . That is,

$$\frac{1}{y} \frac{dy}{dt} = a(t).$$

17. True. Note that the function $y(t) = 3$ for all t is an equilibrium solution for the equation. The Uniqueness Theorem says that graphs of different solutions cannot touch. Hence, a solution with $y(0) > 3$ must have $y(t) > 3$ for all t .

18. False. For example, $dy/dt = y$ has one source ($y = 0$) and no sinks.

19. False. By the Uniqueness Theorem, graphs of different solutions cannot touch. Hence, if one solution $y_1(t) \rightarrow \infty$ as t increases, any solution $y_2(t)$ with $y_2(0) > y_1(0)$ satisfies $y_2(t) > y_1(t)$ for all t . Therefore, $y_2(t) \rightarrow \infty$ as t increases.

20. False. The general solution of this differential equation has the form $y(t) = ke^t + \alpha e^{-t}$, where k is any constant and α is a particular constant (in fact, $\alpha = -1/2$). Choosing $k = 0$, we obtain a solution that tends to 0 as $t \rightarrow \infty$.

21. (a) The equation is autonomous, separable, and linear and nonhomogeneous.

- (b) The general solution to the associated homogeneous equation is $y_h(t) = ke^{-2t}$. For a particular solution of the nonhomogeneous equation, we guess a solution of the form $y_p(t) = \alpha$. Then

$$\frac{dy_p}{dt} + 2y_p = 2\alpha.$$

Consequently, we must have $2\alpha = 3$ for $y_p(t)$ to be a solution. Hence, $\alpha = 3/2$, and the general solution to the nonhomogeneous equation is

$$y(t) = \frac{3}{2} + ke^{-2t}.$$

22. The constant function $y(t) = 0$ is an equilibrium solution.

For $y \neq 0$ we separate the variables and integrate

$$\begin{aligned} \int \frac{dy}{y} &= \int t \, dt \\ \ln |y| &= \frac{t^2}{2} + c \\ |y| &= c_1 e^{t^2/2} \end{aligned}$$

where $c_1 = e^c$ is an arbitrary positive constant.

If $y > 0$, then $|y| = y$ and we can just drop the absolute value signs in this calculation. If $y < 0$, then $|y| = -y$, so $-y = c_1 e^{t^2/2}$. Hence, $y = -c_1 e^{t^2/2}$. Therefore,

$$y = k e^{t^2/2}$$

where $k = \pm c_1$. Moreover, if $k = 0$, we get the equilibrium solution. Thus, $y = k e^{t^2/2}$ yields all solutions to the differential equation if we let k be any real number. (Strictly speaking we need a theorem from Section 1.5 to justify the assertion that this formula provides all solutions.)

23. (a) The equation is linear and nonhomogeneous. (It is nonautonomous as well.)
 (b) The general solution of the associated homogeneous equation is $y_h(t) = k e^{3t}$. For a particular solution of the nonhomogeneous equation, we guess a solution of the form $y_p(t) = \alpha e^{7t}$. Then

$$\frac{dy_p}{dt} - 3y_p = 7\alpha e^{7t} - 3\alpha e^{7t} = 4\alpha e^{7t}.$$

Consequently, we must have $4\alpha = 1$ for $y_p(t)$ to be a solution. Hence, $\alpha = 1/4$, and the general solution to the nonhomogeneous equation is

$$y(t) = k e^{3t} + \frac{1}{4} e^{7t}.$$

24. (a) This equation is linear and homogeneous as well as separable.
 (b) The Linearity Principle implies that

$$\begin{aligned} y(t) &= k e^{\int t/(1+t^2) dt} \\ &= k e^{\frac{1}{2} \ln(1+t^2)} \\ &= k \sqrt{1+t^2}, \end{aligned}$$

where k can be any real number (see page 113 in Section 1.8).

25. (a) This equation is linear and nonhomogeneous.
 (b) To find the general solution, we first note that $y_h(t) = k e^{-5t}$ is the general solution of the associated homogeneous equation.

To get a particular solution of the nonhomogeneous equation, we guess

$$y_p(t) = \alpha \cos 3t + \beta \sin 3t.$$

Substituting this guess into the nonhomogeneous equation gives

$$\begin{aligned} \frac{dy_p}{dt} + 5y_p &= -3\alpha \sin 3t + 3\beta \cos 3t + 5\alpha \cos 3t + 5\beta \sin 3t \\ &= (5\alpha + 3\beta) \cos 3t + (5\beta - 3\alpha) \sin 3t. \end{aligned}$$

In order for $y_p(t)$ to be a solution, we must solve the simultaneous equations

$$\begin{cases} 5\alpha + 3\beta = 0 \\ 5\beta - 3\alpha = 1. \end{cases}$$

From these equations, we get $\alpha = -3/34$ and $\beta = 5/34$. Hence, the general solution is

$$y(t) = k e^{-5t} - \frac{3}{34} \cos 3t + \frac{5}{34} \sin 3t.$$

26. (a) This equation is linear and nonhomogeneous.
 (b) We rewrite the equation in the form

$$\frac{dy}{dt} - \frac{2y}{1+t} = t$$

and note that the integrating factor is

$$\mu(t) = e^{\int -2/(1+t) dt} = e^{-2 \ln(1+t)} = \frac{1}{(1+t)^2}.$$

Multiplying both sides of the differential equation by $\mu(t)$, we obtain

$$\frac{1}{(1+t)^2} \frac{dy}{dt} - \frac{2y}{(1+t)^3} = \frac{t}{(1+t)^2}.$$

Applying the Product Rule to the left-hand side, we see that this equation is the same as

$$\frac{d}{dt} \left(\frac{y}{(1+t)^2} \right) = \frac{t}{(1+t)^2}.$$

Integrating both sides with respect to t and using the substitution $u = 1 + t$ on the right-hand side, we obtain

$$\frac{y}{(1+t)^2} = \frac{1}{1+t} + \ln|1+t| + k,$$

where k can be any real number. The general solution is

$$y(t) = (1+t) + (1+t)^2 \ln|1+t| + k(1+t)^2.$$

27. (a) The equation is autonomous and separable.
 (b) When we separate variables, we obtain

$$\int \frac{1}{3+y^2} dy = \int dt.$$

Integrating, we get

$$\frac{1}{\sqrt{3}} \arctan \left(\frac{y}{\sqrt{3}} \right) = t + c,$$

and solving for $y(t)$ produces

$$y(t) = \sqrt{3} \tan \left(\sqrt{3}t + k \right).$$

28. (a) This equation is separable and autonomous.
 (b) First, note that $y = 0$ and $y = 2$ are the equilibrium points. Assuming that $y \neq 0$ and $y \neq 2$, we separate variables to obtain

$$\int \frac{1}{2y - y^2} dy = \int dt.$$

To integrate the left-hand side, we use partial fractions. We write

$$\frac{1}{y(2-y)} = \frac{A}{y} + \frac{B}{2-y},$$

which gives $2A = 1$ and $-A + B = 0$. So $A = B = 1/2$, and

$$\int \frac{1}{2y-y^2} dy = \frac{1}{2} \left(\int \frac{1}{y} + \frac{1}{2-y} dy \right) = \frac{1}{2} \ln \left| \frac{y}{y-2} \right|.$$

After integrating, we have

$$\ln \left| \frac{y}{y-2} \right| = 2t + c$$

$$\left| \frac{y}{y-2} \right| = c_1 e^{2t},$$

where $c_1 = e^c$ is any positive constant. To remove the absolute value signs, we replace the positive constant c_1 by a constant k that can be any real number and get

$$\frac{y}{y-2} = ke^{2t}.$$

After solving for y , we obtain

$$y(t) = \frac{2ke^{2t}}{ke^{2t} - 1}.$$

Note that $k = 0$ corresponds to the equilibrium solution $y = 0$. However, no value of k yields the equilibrium solution $y = 2$.

29. (a) This equation is linear and nonhomogeneous.

(b) First we note that the general solution of the associated homogeneous equation is ke^{-3t} .

Next we use the technique suggested in Exercise 19 of Section 1.8. We could find particular solutions of the two nonhomogeneous equations

$$\frac{dy}{dt} = -3y + e^{-2t} \quad \text{and} \quad \frac{dy}{dt} = -3y + t^2$$

separately and add the results to obtain a particular solution for the original equation. However, these two steps can be combined by making a more complicated guess for the particular solution.

We guess $y_p(t) = ae^{-2t} + bt^2 + ct + d$, and we have

$$\begin{aligned} \frac{dy_p}{dt} + 3y_p &= -2ae^{-2t} + 2bt + c + 3ae^{-2t} + 3bt^2 + 3ct + d \\ &= ae^{-2t} + 3bt^2 + (2b + 3c)t + (c + 3d). \end{aligned}$$

Hence, for $y_p(t)$ to be a solution we must have $a = 1$, $b = \frac{1}{3}$, $c = -\frac{2}{9}$, and $d = \frac{2}{27}$. Therefore, a particular solution is $y_p(t) = e^{-2t} + \frac{1}{3}t^2 - \frac{2}{9}t + \frac{2}{27}$, and the general solution is

$$y(t) = ke^{-3t} + e^{-2t} + \frac{1}{3}t^2 - \frac{2}{9}t + \frac{2}{27}.$$

30. (a) The equation is separable, linear and homogeneous.
 (b) We know that the general solution of this equation has the form

$$x(t) = ke^{\int -2t dt},$$

where k is an arbitrary constant. We get $x(t) = ke^{-t^2}$.

To satisfy the initial condition $x(0) = e$, we note that $x(0) = k$, so $k = e$. The solution of the initial-value problem is

$$x(t) = ee^{-t^2} = e^{1-t^2}.$$

31. (a) This equation is linear and nonhomogeneous. (It is nonautonomous as well.)
 (b) The general solution of the associated homogeneous equation is $y_h(t) = ke^{2t}$. To find a particular solution of the nonhomogeneous equation, we guess $y_p(t) = \alpha \cos 4t + \beta \sin 4t$. Then

$$\begin{aligned} \frac{dy_p}{dt} - 2y_p &= -4\alpha \sin 4t + 4\beta \cos 4t - 2(\alpha \cos 4t + \beta \sin 4t) \\ &= (-2\alpha + 4\beta) \cos 4t + (-4\alpha - 2\beta) \sin 4t. \end{aligned}$$

Consequently, we must have

$$(-2\alpha + 4\beta) \cos 4t + (-4\alpha - 2\beta) \sin 4t = \cos 4t$$

for $y_p(t)$ to be a solution. We must solve

$$\begin{cases} -2\alpha + 4\beta = 1 \\ -4\alpha - 2\beta = 0. \end{cases}$$

Hence, $\alpha = -1/10$ and $\beta = 1/5$, and the general solution of the nonhomogeneous equation is

$$y(t) = ke^{2t} - \frac{1}{10} \cos 4t + \frac{1}{5} \sin 4t.$$

To find the solution of the given initial-value problem, we evaluate the general solution at $t = 0$ and obtain

$$y(0) = k - \frac{1}{10}.$$

Since the initial condition is $y(0) = 1$, we see that $k = 11/10$. The desired solution is

$$y(t) = \frac{11}{10}e^{2t} - \frac{1}{10} \cos 4t + \frac{1}{5} \sin 4t.$$

32. (a) This equation is linear and nonhomogeneous.
 (b) We first find the general solution. The general solution of the associated homogeneous equation is $y_h(t) = ke^{3t}$. For a particular solution of the nonhomogeneous equation, we guess $y_p(t) = \alpha te^{3t}$ rather than αe^{3t} because αe^{3t} is a solution of the homogeneous equation. Then

$$\begin{aligned} \frac{dy_p}{dt} - 3y_p &= \alpha e^{3t} + 3\alpha te^{3t} - 3\alpha te^{3t} \\ &= \alpha e^{3t}. \end{aligned}$$

Consequently, we must have $\alpha = 2$ for $y_p(t)$ to be a solution. Hence, the general solution to the nonhomogeneous equation is

$$y(t) = ke^{3t} + 2te^{3t}.$$

Note that $y(0) = k$, so the solution to the initial-value problem is

$$y(t) = -e^{3t} + 2te^{3t} = (2t - 1)e^{3t}.$$

33. (a) The equation is separable because

$$\frac{dy}{dt} = (t^2 + 1)y^3.$$

(b) Separating variables and integrating, we have

$$\begin{aligned}\int y^{-3} dy &= \int (t^2 + 1) dt \\ \frac{y^{-2}}{-2} &= \frac{t^3}{3} + t + c \\ y^{-2} &= -\frac{2}{3}t^3 - 2t + k.\end{aligned}$$

Using the initial condition $y(0) = -1/2$, we get that $k = 4$. Therefore,

$$y^2 = \frac{1}{4 - 2t - \frac{2}{3}t^3}.$$

Taking the square root of both sides yields

$$y = \frac{\pm 1}{\sqrt{4 - 2t - \frac{2}{3}t^3}}.$$

In this case, we take the negative square root because $y(0) = -1/2$. The solution to the initial-value problem is

$$y(t) = \frac{-1}{\sqrt{4 - 2t - \frac{2}{3}t^3}}.$$

34. The general solution to the associated homogeneous equation is $y_h(t) = ke^{-5t}$. For a particular solution of the nonhomogeneous equation, we guess $y_p(t) = \alpha te^{-5t}$ rather than αe^{-5t} because αe^{-5t} is a solution of the homogeneous equation. Then

$$\begin{aligned}\frac{dy_p}{dt} + 5y_p &= \alpha e^{-5t} - 5\alpha te^{-5t} + 5\alpha te^{-5t} \\ &= \alpha e^{-5t}.\end{aligned}$$

Consequently, we must have $\alpha = 3$ for $y_p(t)$ to be a solution. Hence, the general solution to the nonhomogeneous equation is

$$y(t) = ke^{-5t} + 3te^{-5t}.$$

Note that $y(0) = k$, so the solution to the initial-value problem is

$$y(t) = -2e^{-5t} + 3te^{-5t} = (3t - 2)e^{-5t}.$$

- 35. (a)** This equation is linear and nonhomogeneous. (It is nonautonomous as well.)
(b) We rewrite the equation as

$$\frac{dy}{dt} - 2ty = 3te^{t^2}$$

and note that the integrating factor is

$$\mu(t) = e^{\int -2t dt} = e^{-t^2}.$$

Multiplying both sides by $\mu(t)$, we obtain

$$e^{-t^2} \frac{dy}{dt} - 2te^{-t^2} y = 3t.$$

Applying the Product Rule to the left-hand side, we see that this equation is the same as

$$\frac{d}{dt} (e^{-t^2} y) = 3t,$$

and integrating both sides with respect to t , we obtain $e^{-t^2} y = \frac{3}{2}t^2 + k$, where k is an arbitrary constant. The general solution is

$$y(t) = \left(\frac{3}{2}t^2 + k\right) e^{t^2}.$$

To find the solution that satisfies the initial condition $y(0) = 1$, we evaluate the general solution at $t = 0$ and obtain $k = 1$. The desired solution is

$$y(t) = \left(\frac{3}{2}t^2 + 1\right) e^{t^2}.$$

- 36. (a)** This equation is separable.
(b) We separate variables and integrate to obtain

$$\int (y + 1)^2 dy = \int (t + 1)^2 dt$$

$$\frac{1}{3}(y + 1)^3 = \frac{1}{3}(t + 1)^3 + k,$$

where k is a constant.

We could solve for $y(t)$ now, but it is much easier to find k first. Using the initial condition $y(0) = 0$, we see that $k = 0$. Hence, the solution of the initial-value problem satisfies the equality

$$\frac{1}{3}(y + 1)^3 = \frac{1}{3}(t + 1)^3,$$

and therefore, $y(t) = t$.

37. (a) This equation is separable.
 (b) We separate variables and integrate to obtain

$$\int \frac{1}{y^2} dy = \int (2t + 3t^2) dt$$

$$-\frac{1}{y} = t^2 + t^3 + k$$

$$y = \frac{-1}{t^2 + t^3 + k}.$$

To find the solution of the initial-value problem, we evaluate the general solution at $t = 1$ and obtain

$$y(1) = \frac{-1}{2 + k}.$$

Since the initial condition is $y(1) = -1$, we see that $k = -1$. The solution to the initial-value problem is

$$y(t) = \frac{1}{1 - t^2 - t^3}.$$

38. (a) This equation is autonomous and separable.
 (b) Note that the equilibrium points are $y = \pm 1$. Since the initial condition is $y(0) = 1$, we know that the solution to the initial-value problem is the equilibrium solution $y(t) = 1$ for all t .
39. (a) The differential equation is separable.
 (b) We can write the equation in the form

$$\frac{dy}{dt} = \frac{t^2}{y(t^3 + 1)}$$

and separate variables to get

$$\int y dy = \int \frac{t^2}{t^3 + 1} dt$$

$$\frac{y^2}{2} = \frac{1}{3} \ln |t^3 + 1| + c,$$

where c is a constant. Hence,

$$y^2 = \frac{2}{3} \ln |t^3 + 1| + 2c.$$

The initial condition $y(0) = -2$ implies

$$(-2)^2 = \frac{2}{3} \ln |1| + 2c.$$

Thus, $c = 2$, and

$$y(t) = -\sqrt{\frac{2}{3} \ln |t^3 + 1| + 4}.$$

We choose the negative square root because $y(0)$ is negative.

40. (a)

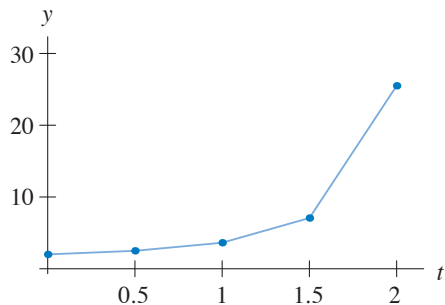

(b)

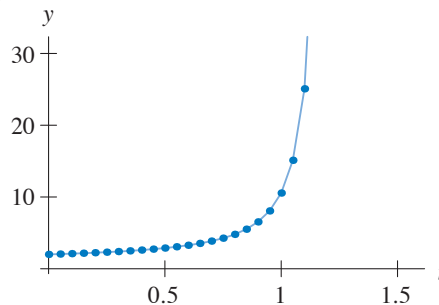

(c) Note that

$$\frac{dy}{dt} = (y - 1)^2.$$

Separating variables and integrating, we get

$$\int \frac{1}{(y - 1)^2} dy = \int 1 dt$$

$$\frac{1}{1 - y} = t + k.$$

From the initial condition, we see that $k = -1$, and we have

$$\frac{1}{1 - y} = t - 1.$$

Solving for y yields

$$y(t) = \frac{t - 2}{t - 1},$$

which blows up as $t \rightarrow 1$ from below.

41. (a)

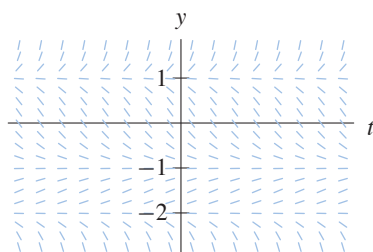

(b)

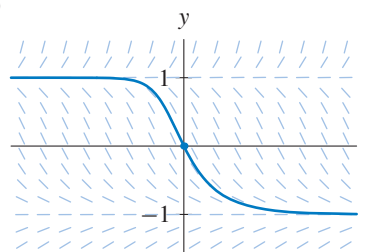

42. (a)

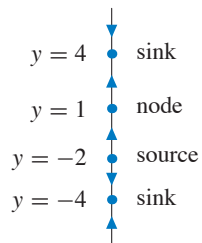

(b)

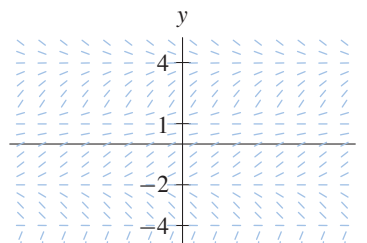

(c)

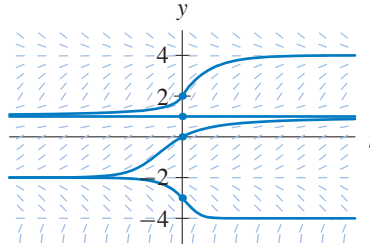

43. The constant function $y(t) = 2$ for all t is an equilibrium solution. If $y > 2$, then $dy/dt > 0$. Moreover, solutions with initial conditions above $y = 2$ satisfy $y(t) \rightarrow \infty$ as t increases and $y(t) \rightarrow 2$ as $t \rightarrow -\infty$.

If $y < -2$, then $dy/dt > 0$, so solutions with initial conditions below $y = -2$ increase until they cross the line $y = -2$. If $0 < y < 2$, then $dy/dt < 0$, and solutions in this strip decrease until they cross the t -axis.

For all initial conditions on the y -axis below $y = 2$, the solutions tend toward a periodic solution of period 2π as t increases. This periodic solution crosses the y -axis at $y_0 \approx -0.1471$. If $y(0) < y_0$, then the solution satisfies $y(t) \rightarrow -\infty$ as t decreases. If $y_0 < y(0) < 2$, the $y(t) \rightarrow 2$ as $t \rightarrow -\infty$.

44. From the equation, we can see that the functions $y_1(t) = 1$ for all t and $y_2(t) = 2$ for all t are equilibrium solutions. The Uniqueness Theorem tells us that solutions with initial conditions that satisfy $1 < y(0) < 2$ must also satisfy $1 < y(t) < 2$ for all t . An analysis of the sign of dy/dt within this strip indicates that $y(t) \rightarrow 2$ as $t \rightarrow \pm\infty$ if $1 < y(0) < 2$. All such solutions decrease until they intersect the curve $y = e^{t/2}$ and then they increase thereafter.

Solutions with $y(0)$ slightly greater than 2 increase until they intersect the curve $y = e^{t/2}$ and then they decrease and approach $y = 2$ as $t \rightarrow \infty$.

Solutions with $y(0)$ somewhat larger (approximately $y(0) > 2.1285$) increase quickly. It is difficult to determine if they eventually decrease, if they blow up in finite time, or if they increase for all time. In all cases where $y(0) > 2$, $y(t) \rightarrow 2$ as $t \rightarrow -\infty$.

Solutions with $y(0) < 1$ satisfy $y(t) \rightarrow -\infty$ as t increases, perhaps in finite time. As $t \rightarrow -\infty$, $y(t) \rightarrow 0$ for these solutions.

45. Note that

$$\frac{dy}{dt} = (1 + t^2)y + 1 + t^2 = (1 + t^2)(y + 1).$$

(a) Separating variables and integrating, we obtain

$$\int \frac{1}{y+1} dy = \int (1+t^2) dt$$

$$\ln |y+1| = t + \frac{t^3}{3} + c,$$

where c is any constant. Thus, $|y+1| = c_1 e^{t+t^3/3}$, where $c_1 = e^c$. We can dispose of the absolute value signs by allowing the constant c_1 to be any real number. In other words,

$$y(t) = -1 + k e^{t+t^3/3},$$

where $k = \pm c_1$. Note that, if $k = 0$, we have the equilibrium solution $y(t) = -1$ for all t .

- (b) The associated homogeneous equation is $dy/dt = (1+t^2)y$, and the Linearity Principle implies that

$$\begin{aligned} y(t) &= ke^{\int(1+t^2)dt} \\ &= ke^{t+t^3/3}. \end{aligned}$$

where k can be any real number (see page 113 in Section 1.8).

- (c) When we write the differential equation as $dy/dt = (1+t^2)(y+1)$, we can immediately see that $y = -1$ corresponds to the equilibrium solution $y(t) = -1$ for all t .
- (d) This equilibrium solution is a particular solution of the nonhomogeneous equation. Therefore, using the result of part (b), we get the general solution

$$y(t) = -1 + ke^{t+t^3/3}$$

of the nonhomogeneous equation using the Extended Linearity Principle. Note that this result agrees with the result of part (a).

46. (a) Note that there is an equilibrium solution of the form $y = -1/2$. Separating variables and integrating, we obtain

$$\begin{aligned} \int \frac{1}{2y+1} dy &= \int \frac{1}{t} dt \\ \frac{1}{2} \ln |2y+1| &= \ln |t| + c \\ \ln |2y+1| &= (\ln t^2) + c \\ |2y+1| &= c_1 t^2, \end{aligned}$$

where $c_1 = e^c$. We can eliminate the absolute value signs by allowing the constant to be either positive or negative. In other words, $2y+1 = k_1 t^2$, where $k_1 = \pm c_1$. Hence

$$y(t) = kt^2 - \frac{1}{2},$$

where $k = k_1/2$.

- (b) As t approaches zero all the solutions approach $-1/2$. In fact, $y(0) = -1/2$ for every value of k .
- (c) This example does not violate the Uniqueness Theorem because the differential equation is not defined at $t = 0$. So functions $y(t)$ can only be said to be solutions for $t \neq 0$.

47. (a) Using Euler's method, we obtain the values $y_0 = 0$, $y_1 = 1.5$, $y_2 = 1.875$, $y_3 = 1.617$, and $y_4 = 1.810$ (rounded to three decimal places).

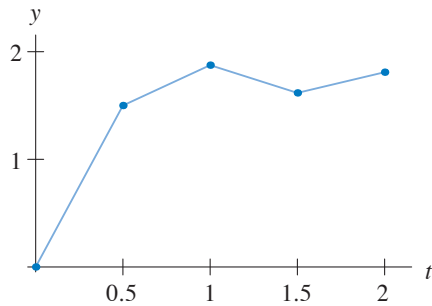

- (b)

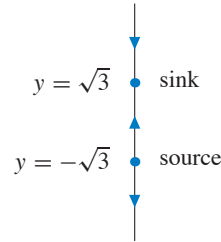

- (c) The phase line tells us that the solution with initial condition $y(0) = 0$ must be increasing. Moreover, its graph is below and asymptotic to the line $y = \sqrt{3}$ as $t \rightarrow \infty$. The oscillations obtained using Euler's method come from numerical error.

48. (a) If we let k denote the proportionality constant in Newton's law of cooling, the initial-value problem satisfied by the temperature T of the soup is

$$\frac{dT}{dt} = k(T - 70), \quad T(0) = 150.$$

- (b) We can solve the initial-value problem in part (a) using the fact that this equation is a nonhomogeneous linear equation. The function $T(t) = 70$ for all t is clearly an equilibrium solution to the equation. Therefore, the Extended Linearity Principle tells us that the general solution is

$$T(t) = 70 + ce^{kt},$$

where c is a constant determined by the initial condition. Since $T(0) = 150$, we have $c = 80$. To determine k , we use the fact that $T(1) = 140$. We get

$$\begin{aligned} 140 &= 70 + 80e^k \\ 70 &= 80e^k \\ \frac{7}{8} &= e^k. \end{aligned}$$

We conclude that $k = \ln(7/8)$.

In order to find t so that the temperature is 100° , we solve

$$100 = 70 + 80e^{\ln(7/8)t}$$

for t . We get $\ln(3/8) = \ln(7/8)t$, which yields $t = \ln(3/8)/\ln(7/8) \approx 7.3$ minutes.

49. (a) Note that the slopes are constant along vertical lines—lines along which t is constant, so the right-hand side of the corresponding equation depends only on t . The only choices are equations (i) and (iv). Because the slopes are negative for $t > 1$ and positive for $t < 1$, this slope field corresponds to equation (iv).

- (b) This slope field has an equilibrium solution corresponding to the line $y = 1$, as does equations (ii), (v), (vii), and (viii). Equations (ii), (v), and (viii) are autonomous, and this slope field is not constant along horizontal lines. Consequently, it corresponds to equation (vii).
- (c) This slope field is constant along horizontal lines, so it corresponds to an autonomous equation. The autonomous equations are (ii), (v), and (viii). This field does not correspond to equation (v) because it has the equilibrium solution $y = -1$. The slopes are negative between $y = -1$ and $y = 1$. Consequently, this field corresponds to equation (viii).
- (d) This slope field depends both on y and on t , so it can only correspond to equations (iii), (vi), or (vii). It does not correspond to (vii) because it does not have an equilibrium solution at $y = 1$. Also, the slopes are positive if $y > 0$. Therefore, it must correspond to equation (vi).
50. (a) Let t be time measured in years with $t = 0$ corresponding to the time of the first deposit, and let $M(t)$ be Beth's balance at time t . The 52 weekly deposits of \$20 are approximately the same as a continuous yearly rate of \$1,040. Therefore, the initial-value problem that models the growth in savings is

$$\frac{dM}{dt} = 0.011M + 1,040, \quad M(0) = 400.$$

- (b) The differential equation is both linear and separable, so we can solve the initial-value problem by separating variables, using an integrating factor, or using the Extended Linearity Principle. We use the Extended Linearity Principle.

The general solution of the associated homogeneous equation is $ke^{0.011t}$. We obtain one particular solution of the nonhomogeneous equation by determining its equilibrium solution. The equilibrium point is $M = -1,040/0.011 \approx -94,545$. Therefore, the general solution of the nonhomogeneous equation is

$$M(t) = ke^{0.011t} - 94,545.$$

Since $M(0) = 400$, we have $k = 94,945$, and after four years, Beth balance is $M(4) \approx 94,945e^{0.044} - 94,545 \approx \$4,671$.

51. (a)

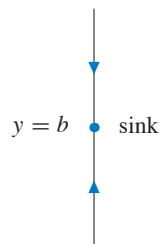

- (b) As $t \rightarrow \infty$, $y(t) \rightarrow b$ for every solution $y(t)$.
- (c) The equation is separable and linear. Hence, you can find the general solution by separating variables or by either of the methods for solving linear equations (undetermined coefficients or integrating factors).
- (d) The associated homogeneous equation is $dy/dt = -(1/a)y$, and its general solution is $ke^{-t/a}$. One particular solution of the nonhomogeneous equation is the equilibrium solution $y(t) = b$ for all t . Therefore, the general solution of the nonhomogeneous equation is

$$y(t) = ke^{-t/a} + b.$$

- (e) The authors love all the methods, just in different ways and for different reasons.
- (f) Since $a > 0$, $e^{-t/a} \rightarrow 0$ as $t \rightarrow \infty$. Hence, $y(t) \rightarrow b$ as $t \rightarrow \infty$ independent of k .

52. (a) The equation is separable. Separating variables and integrating, we obtain

$$\int y^{-2} dy = \int -2t dt$$

$$-y^{-1} = -t^2 + c,$$

where c is a constant of integration. Multiplying both sides by -1 and inverting yields

$$y(t) = \frac{1}{t^2 + k},$$

where k can be any constant. In addition, the equilibrium solution $y(t) = 0$ for all t is a solution.

- (b) If $y(-1) = y_0$, we have

$$y_0 = y(-1) = \frac{1}{1 + k}$$

so

$$k = \frac{1}{y_0} - 1.$$

As long as $k > 0$, the denominator is positive for all t , and the solution is bounded for all t . Hence, for $0 \leq y_0 < 1$, the solution is bounded for all t . (Note that $y_0 = 0$ corresponds to the equilibrium solution.) All other solutions escape to $\pm\infty$ in finite time.

53. (a) Let $C(t)$ be the volume of carbon monoxide at time t where t is measured in hours. Initially, the amount of the carbon monoxide is 3% by volume. Since the volume of the room is 1000 cubic feet, there are 30 cubic feet of carbon monoxide in the room at time $t = 0$. Carbon monoxide is being blown into the room at the rate of one cubic foot per hour. The concentration of carbon monoxide is $C/1000$, so carbon monoxide leaves the room at the rate of

$$100 \left(\frac{C}{1000} \right).$$

The initial-value problem that models this situation is

$$\frac{dC}{dt} = 1 - \frac{C}{10}, \quad C(0) = 30.$$

- (b) There is one equilibrium point, $C = 10$, and it is a sink. As t increases, $C(t)$ approaches 10, so the concentration approaches 1% carbon monoxide, the concentration of the air being blown into the room.

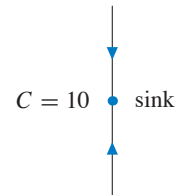

- (c) The differential equation is linear. It is also autonomous and, therefore, separable. We can solve the initial-value problem by separating variables, using integrating factors, or by the Extended Linearity Principle. Since we already know one solution to the equation, that is, the equilibrium solution, we use the Extended Linearity Principle.

The associated homogeneous equation is $dC/dt = -C/10$, and its general solution is $ke^{-0.1t}$. Therefore, the general solution of the nonhomogeneous equation is

$$C(t) = 10 + ke^{-0.1t}.$$

given $C(0) = 30, k = 20$.

To find the value of t for which $C(t) = 20$, we solve

$$10 + 20e^{-t/10} = 20$$

We get

$$\begin{aligned} 20e^{-t/10} &= 10 \\ e^{-t/10} &= \frac{1}{2} \\ -t/10 &= \ln\left(\frac{1}{2}\right) \\ t &= 10 \ln 2. \end{aligned}$$

The air in the room is 2% carbon monoxide in approximately 6.93 hours.

- 54.** Let $s(t)$ be the amount (measured in gallons) of cherry syrup in the vat at time t (measured in minutes). Then ds/dt is the difference between the rates at which syrup is added and syrup is withdrawn. Syrup is added at the rate of 2 gallons per minute. Syrup is withdrawn at the rate of

$$5 \left(\frac{s}{500 + 5t} \right)$$

gallons per minute because the well mixed solution is withdrawn at the rate of 5 gallons per minute and the concentration of syrup is the total amount of syrup, s , divided by the total volume, $500 + 5t$. The differential equation is

$$\frac{ds}{dt} = 2 - \frac{s}{100 + t}.$$

We solve this equation using integrating factors. Rewriting the equation as

$$\frac{ds}{dt} + \frac{s}{100 + t} = 2,$$

we see that the integrating factor is

$$\mu(t) = e^{\int 1/(100+t) dt} = e^{\ln(100+t)} = 100 + t.$$

Multiplying both sides of the differential equation by the integrating factor gives

$$(100 + t) \frac{ds}{dt} + s = 2(100 + t).$$

Using the Product Rule on the left-hand side, we observe that this equation can be rewritten as

$$\frac{d((100 + t)s)}{dt} = 2t + 200,$$

and we integrate both sides to obtain

$$(100 + t)s = t^2 + 200t + c,$$

where c is a constant that is determined by the initial condition $s(0) = 50$. Since

$$s(t) = \frac{t^2 + 200t + c}{t + 100},$$

we see that $c = 5000$. Therefore, the solution of the initial-value problem is

$$s(t) = \frac{t^2 + 200t + 5000}{t + 100}.$$

The vat is full when $500 + 5t = 1000$, that is, when $t = 100$ minutes. The amount of cherry syrup in the vat at that time is $s(100) = 175$ gallons, so the concentration is $175/1000 = 17.5\%$.

The image features a light blue background with a white rectangular area in the top-left corner. Four blue lines curve from the left edge of this white area towards the right, framing the text. The text 'First-Order Systems' is centered within the white area.

**First-Order
Systems**

EXERCISES FOR SECTION 2.1

- In the case where it takes many predators to eat one prey, the constant in the negative effect term of predators on the prey is small. Therefore, (ii) corresponds to the system of large prey and small predators. On the other hand, one predator eats many prey for the system of large predators and small prey, and, therefore, the coefficient of negative effect term on predator-prey interaction on the prey is large. Hence, (i) corresponds to the system of small prey and large predators.
- For (i), the equilibrium points are $x = y = 0$ and $x = 10, y = 0$. For the latter equilibrium point prey alone exist; there are no predators. For (ii), the equilibrium points are $(0, 0)$, $(0, 15)$, and $(3/5, 30)$. For the latter equilibrium point, both species coexist. For $(0, 15)$, the prey are extinct but the predators survive.

- Substitution of $y = 0$ into the equation for dy/dt yields $dy/dt = 0$ for all t . Therefore, $y(t)$ is constant, and since $y(0) = 0, y(t) = 0$ for all t .
Note that to verify this assertion rigorously, we need a uniqueness theorem (see Section 2.5).

- For (i), the prey obey a logistic model. The population tends to the equilibrium point at $x = 10$. For (ii), the prey obey an exponential growth model, so the population grows unchecked.

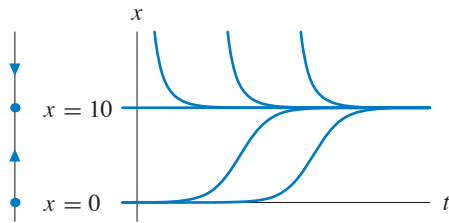

Phase line and graph for (i).

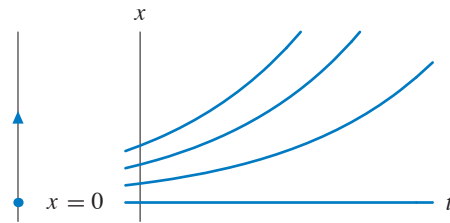

Phase line and graph for (ii).

- Substitution of $x = 0$ into the equation for dx/dt yields $dx/dt = 0$ for all t . Therefore, $x(t)$ is constant, and since $x(0) = 0, x(t) = 0$ for all t .
Note that to verify this assertion rigorously, we need a uniqueness theorem (see Section 2.5).

- For (i), the predators obey an exponential decay model, so the population tends to 0. For (ii), the predators obey a logistic model. The population tends to the equilibrium point at $y = 15$.

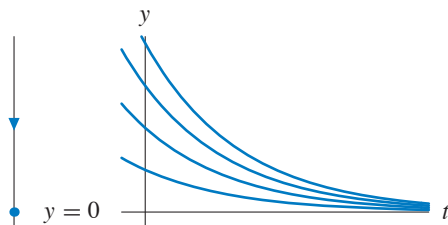

Phase line and graph for (i).

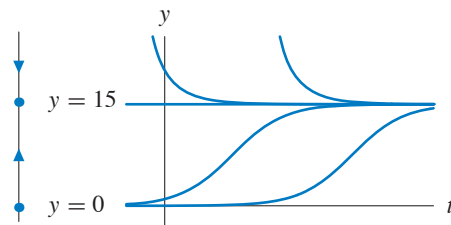

Phase line and graph for (ii).

7. The population starts with a relatively large rabbit (R) and a relatively small fox (F) population. The rabbit population grows, then the fox population grows while the rabbit population decreases. Next the fox population decreases until both populations are close to zero. Then the rabbit population grows again and the cycle starts over. Each repeat of the cycle is less dramatic (smaller total oscillation) and both populations oscillate toward an equilibrium which is approximately $(R, F) = (1/2, 3/2)$.

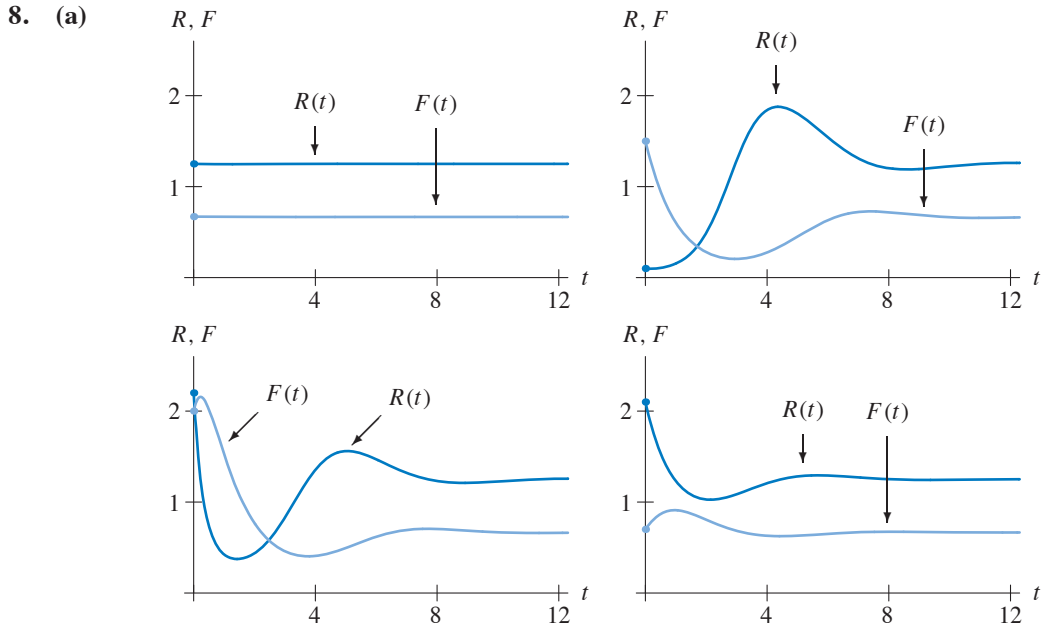

(b) Each of the solutions tends to the equilibrium point at $(R, F) = (5/4, 2/3)$. The populations of both species tend to a limit and the species coexist. For curve B, note that the F -population initially decreases while R increases. Eventually F bottoms out and begins to rise. Then R peaks and begins to fall. Then both populations tend to the limit.

9. By hunting, the number of prey decreases α units per unit of time. Therefore, the rate of change dR/dt of the number of prey has the term $-\alpha$. Only the equation for dR/dt needs modification.

(i) $dR/dt = 2R - 1.2RF - \alpha$
 (ii) $dR/dt = R(2 - R) - 1.2RF - \alpha$

10. Hunting decreases the number of predators by an amount proportional to the number of predators alive (that is, by a term of the form $-kF$), so we have $dF/dt = -F + 0.9RF - kF$ in each case.

11. Since the second food source is unlimited, if $R = 0$ and k is the growth parameter for the predator population, F obeys an exponential growth model, $dF/dt = kF$. The only change we have to make is in the rate of F , dF/dt . For both (i) and (ii), $dF/dt = kF + 0.9RF$.

12. In the absence of prey, the predators would obey a logistic growth law. So we could modify both systems by adding a term of the form $-kF/N$, where k is the growth-rate parameter and N is the carrying capacity of predators. That is, we have $dF/dt = kF(1 - F/N) + 0.9RF$.

13. If $R - 5F > 0$, the number of predators increases and, if $R - 5F < 0$, the number of predators decreases. Since the condition on prey is same, we modify only the predator part of the system. the modified rate of change of the predator population is

$$\frac{dF}{dt} = -F + 0.9RF + k(R - 5F)$$

where $k > 0$ is the immigration parameter for the predator population.

14. In both cases the rate of change of population of prey decreases by a factor of kF . Hence we have
- (i) $dR/dt = 2R - 1.2RF - kF$
(ii) $dR/dt = 2R - R^2 - 1.2RF - kF$
15. Suppose $y = 1$. If we can find a value of x such that $dy/dt = 0$, then for this x and $y = 1$ the predator population is constant. (This point may not be an equilibrium point because we do not know if $dx/dt = 0$.) The required value of x is $x = 0.05$ in system (i) and $x = 20$ in system (ii). Survival for one unit of predators requires 0.05 units of prey in (i) and 20 units of prey in (ii). Therefore, (i) is a system of inefficient predators and (ii) is a system of efficient predators.
16. At first, the number of rabbits decreases while the number of foxes increases. Then the foxes have too little food, so their numbers begin to decrease. Eventually there are so few foxes that the rabbits begin to multiply. Finally, the foxes become extinct and the rabbit population tends to the constant population $R = 3$.
17. (a) For the initial condition close to zero, the pest population increases much more rapidly than the predator. After a sufficient increase in the predator population, the pest population starts to decrease while the predator population keeps increasing. After a sufficient decrease in the pest population, the predator population starts to decrease. Then, the population comes back to the initial point.
- (b) After applying the pest control, you may see the increase of the pest population due to the absence of the predator. So in the short run, this sort of pesticide can cause an explosion in the pest population.
18. One way to consider this type of predator-prey interaction is to raise the growth rate of the prey population. If only weak or sick prey are removed, the remaining population may be assumed to be able to reproduce at a higher rate.

19. (a) Substituting $y(t) = \sin t$ into the left-hand side of the differential equation gives

$$\begin{aligned} \frac{d^2y}{dt^2} + y &= \frac{d^2(\sin t)}{dt^2} + \sin t \\ &= -\sin t + \sin t \\ &= 0, \end{aligned}$$

so the left-hand side equals the right-hand side for all t .

- (c) These two solutions trace the same curve in the yv -plane—the unit circle.

(b)

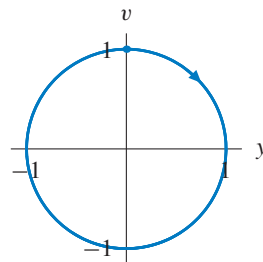

- (d) The difference in the two solution curves is in how they are parameterized. The solution in this problem is at $(0, 1)$ at time $t = 0$ and hence it lags behind the solution in the section by $\pi/2$. This information cannot be observed solely by looking at the solution curve in the phase plane.

20. (a) If we substitute $y(t) = \cos \beta t$ into the left-hand side of the equation, we obtain

$$\begin{aligned} \frac{d^2 y}{dt^2} + \frac{k}{m} y &= \frac{d^2(\cos \beta t)}{dt^2} + \frac{k}{m} \cos \beta t \\ &= -\beta^2 \cos \beta t + \frac{k}{m} \cos \beta t \\ &= \left(\frac{k}{m} - \beta^2 \right) \cos \beta t \end{aligned}$$

Hence, in order for $y(t) = \cos \beta t$ to be a solution we must have $k/m - \beta^2 = 0$. Thus,

$$\beta = \sqrt{\frac{k}{m}}.$$

- (b) Substituting $t = 0$ into $y(t) = \cos \beta t$ and $v(t) = y'(t) = -\beta \sin \beta t$ we obtain the initial conditions $y(0) = 1, v(0) = 0$.

- (c) The solution is $y(t) = \cos((\sqrt{k/m})t)$ and the period of this function is $2\pi/(\sqrt{k/m})$, which simplifies to $2\pi\sqrt{m}/\sqrt{k}$.

- (d)

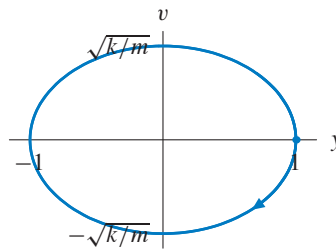

21. Hooke's law tells us that the restoring force exerted by a spring is linearly proportional to the spring's displacement from its rest position. In this case, the displacement is 3 in. while the restoring force is 12 lbs. Therefore, $12 \text{ lbs.} = k \cdot 3 \text{ in.}$ or $k = 4 \text{ lbs. per in.} = 48 \text{ lbs. per ft.}$

22. (a) First, we need to determine the spring constant k . Using Hooke's law, we have $4 \text{ lbs} = k \cdot 4 \text{ in.}$ Thus, $k = 1 \text{ lbs/in} = 12 \text{ lbs/ft.}$ We will measure distance in feet since the mass is extended 1 foot.

To determine the mass of a 4 lb object, we use the fact that the force due to gravity is mg where $g = 32 \text{ ft/sec}^2$. Thus, $m = 4/32 = 1/8$.

Using the model

$$\frac{d^2 y}{dt^2} + \frac{k}{m} y = 0,$$

for the undamped harmonic oscillator, we obtain

$$\frac{d^2 y}{dt^2} + 96y = 0, \quad y(0) = 1, \quad y'(0) = 0$$

as our initial-value problem.

- (b) From Exercise 20 we know that $y(t) = \cos \beta t$ is a solution to the differential equation for the simple harmonic oscillator, where $\beta = \sqrt{k/m}$. Since $y(t) = \cos \sqrt{96}t$ satisfies both our differential equation and our initial conditions, it is the solution to the initial-value problem.
23. An extra firm mattress does not deform when you lay on it. This means that it takes a great deal of force to compress the springs so the spring constant must be large.
24. (a) Let m be the mass of the object, k be the spring constant, and d be the distance the spring is stretched when the mass is attached. Since the force mg stretches the spring a distance d , Hooke's law implies $mg = kd$. Thus, $d = mg/k$. Note that the position $y_1 = 0$ in the first system corresponds to the position $y_2 = -d$ in the second system.

For the first system, the force acting on the mass from the spring is $F_{s_1} = -ky_1$, while in the second system, the force is $F_{s_2} = -k(y_2 + d)$. The reason for the difference is that in the first system the force from the spring is zero when $y_1 = 0$ (the spring has yet to be stretched), while in the second system the force from the spring is zero when $y_2 = -d$. The force due to gravity in either system is mg .

Using Newton's second law of motion, the first system is

$$m \frac{d^2 y_1}{dt^2} = -ky_1 + mg,$$

which can be rewritten as

$$\frac{d^2 y_1}{dt^2} + \frac{k}{m} y_1 - g = 0.$$

For the second system, we have

$$m \frac{d^2 y_2}{dt^2} = -k \left(y_2 + \frac{mg}{k} \right) + mg.$$

This equation can be written as

$$\frac{d^2 y_2}{dt^2} + \frac{k}{m} y_2 = 0.$$

- (b) Letting $dy_1/dt = v_1$, we have

$$\frac{dv_1}{dt} = \frac{d^2 y_1}{dt^2} = -\frac{k}{m} y_1 + g,$$

and the system is

$$\begin{aligned} \frac{dy_1}{dt} &= v_1 \\ \frac{dv_1}{dt} &= -\frac{k}{m} y_1 + g. \end{aligned}$$

Letting $dy_2/dt = v_2$, we have

$$\frac{dv_2}{dt} = \frac{d^2 y_2}{dt^2} = -\frac{k}{m} y_2.$$

Therefore, the second system is

$$\begin{aligned} \frac{dy_2}{dt} &= v_2 \\ \frac{dv_2}{dt} &= -\frac{k}{m} y_2. \end{aligned}$$

The first system has a unique equilibrium point at $(y_1, v_1) = (mg/k, 0)$ while the second has a unique equilibrium point at $(y_2, v_2) = (0, 0)$. The first system is at rest when $y_1 = d = mg/k$ and $v_1 = 0$. The second system is at rest when both $y_2 = 0$ and $v_2 = 0$. The second system is just the standard model of the simple harmonic oscillator while the first system is a translate of this model in the y -coordinate.

- (c) Since the first system is just a translation in the y -coordinate of the second system, we can perform a simple change of variables to transform one to the other. (Note that $y_2 = y_1 - d$.) Thus, if $y_1(t)$ is a solution to the first system, then $y_2(t) = y_1(t) - d$ is a solution to the second system.
- (d) The second system is easy to work with because it has fewer terms and is the more familiar simple harmonic oscillator.
25. Suppose $\alpha > 0$ is the reaction rate constant for $A+B \rightarrow C$. The reaction rate is αab at time t , and after the reaction, a and b decrease by αab . We therefore obtain the system

$$\begin{aligned}\frac{da}{dt} &= -\alpha ab \\ \frac{db}{dt} &= -\alpha ab.\end{aligned}$$

26. Measure the amount of C produced during the short time interval from $t = 0$ to $t = \Delta t$. The amount is given by $a(0) - a(\Delta t)$ since one molecule of A yields one molecule of C . Now

$$\frac{a(0) - a(\Delta t)}{\Delta t} \approx -a'(0) = \alpha a(0)b(0).$$

Since we know $a(0)$, $a(\Delta t)$, $b(0)$, and Δt , we can therefore solve for α .

27. Suppose k_1 and k_2 are the rates of increase of A and B respectively. Since A and B are added to the solution at constant rates, k_1 and k_2 are added to da/dt and db/dt respectively. The system becomes

$$\begin{aligned}\frac{da}{dt} &= k_1 - \alpha ab \\ \frac{db}{dt} &= k_2 - \alpha ab.\end{aligned}$$

28. The chance that two A molecules are close is proportional to a^2 . Hence, the new system is

$$\begin{aligned}\frac{da}{dt} &= k_1 - \alpha ab - \gamma a^2 \\ \frac{db}{dt} &= k_2 - \alpha ab,\end{aligned}$$

where γ is a parameter that measures the rate at which A combines to make D .

29. Suppose γ is the reaction-rate coefficient for the reaction $B + B \rightarrow A$. By the reaction, two B's react with each other to create one A. In other words, B decreases at the rate γb^2 and A increases at the rate $\gamma b^2/2$. The resulting system of the differential equations is

$$\begin{aligned}\frac{da}{dt} &= k_1 - \alpha ab + \frac{\gamma b^2}{2} \\ \frac{db}{dt} &= k_2 - \alpha ab - \gamma b^2.\end{aligned}$$

30. The chance that two B's and an A molecule are close is proportional to ab^2 , so

$$\begin{aligned}\frac{da}{dt} &= k_1 - \alpha ab - \gamma ab^2 \\ \frac{db}{dt} &= k_2 - \alpha ab - 2\gamma ab^2,\end{aligned}$$

where γ is the reaction-rate parameter for the reaction that produces D from two B's and an A.

EXERCISES FOR SECTION 2.2

1. (a) $\mathbf{V}(x, y) = (1, 0)$

(c)

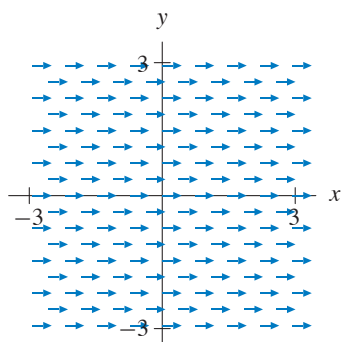

- (b) See part (c).

(d)

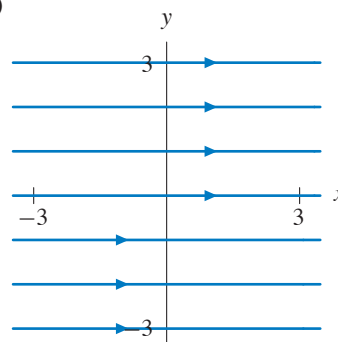

- (e) As t increases, solutions move along horizontal lines toward the right.

2. (a) $\mathbf{V}(x, y) = (x, 1)$

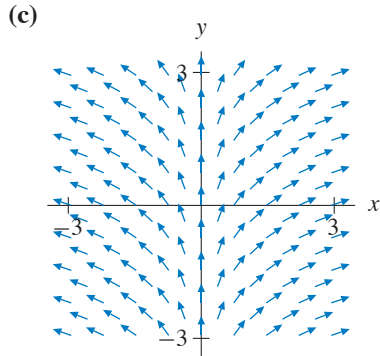

(e) As t increases, solutions move up and right if $x(0) > 0$, up and left if $x(0) < 0$.

(b) See part (c).

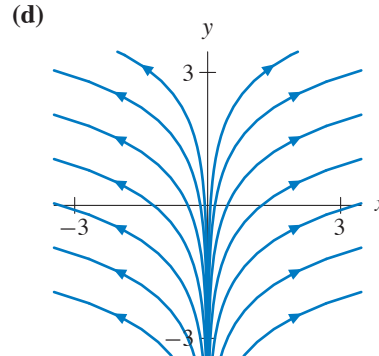

3. (a) $\mathbf{V}(y, v) = (-v, y)$

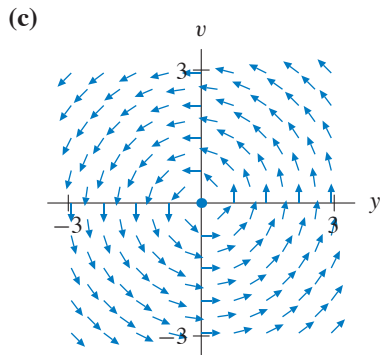

(e) As t increases, solutions move on circles around $(0, 0)$ in the counter-clockwise direction.

(b) See part (c).

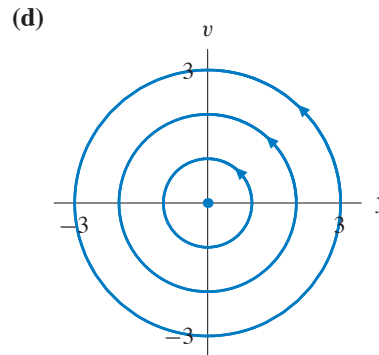

4. (a) $\mathbf{V}(u, v) = (u - 1, v - 1)$

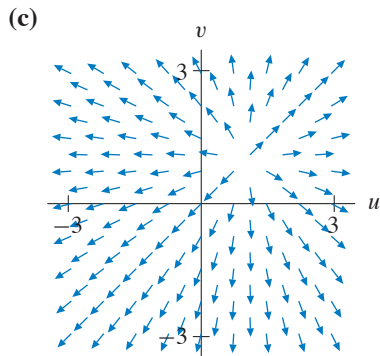

(e) As t increases, solutions move away from the equilibrium point at $(1, 1)$.

(b) See part (c).

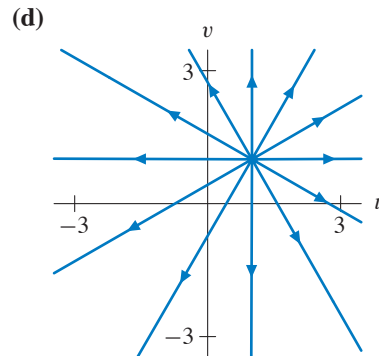

5. (a) $\mathbf{V}(x, y) = (x, -y)$

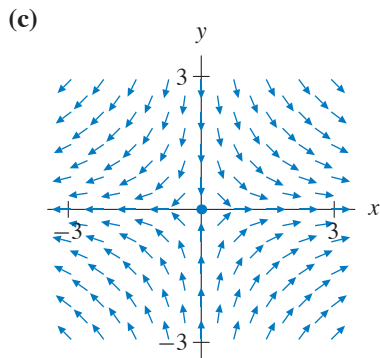

(e) As t increases, solutions move toward the x -axis in the y -direction and away from the y -axis in the x -direction.

- (b) See part (c).

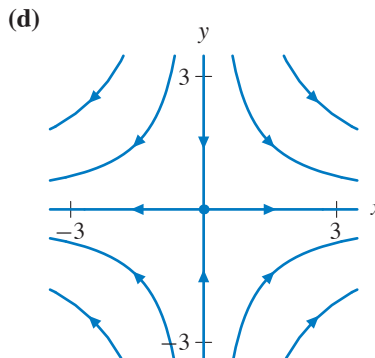

6. (a) $\mathbf{V}(x, y) = (x, 2y)$

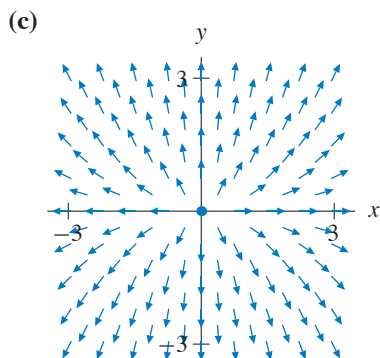

(e) As t increases, solutions move away from the equilibrium point at the origin.

- (b) See part (c).

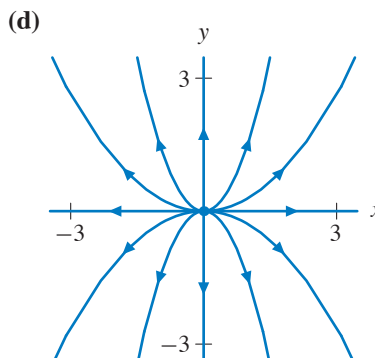

7. (a) Let $v = dy/dt$. Then

$$\frac{dv}{dt} = \frac{d^2y}{dt^2} = y.$$

Thus the associated vector field is

$$\mathbf{V}(y, v) = (v, y).$$

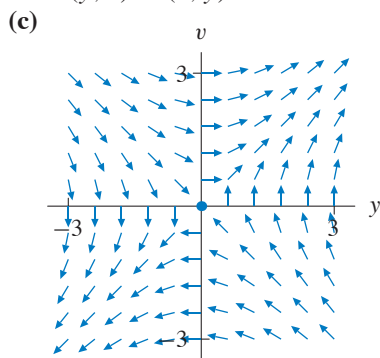

- (b) See part (c).

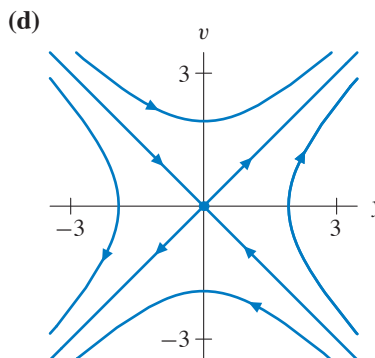

(e) As t increases, solutions in the 2nd and 4th quadrants move toward the origin and away from the line $y = -v$. Solutions in the 1st and 3rd quadrants move away from the origin and toward the line $y = v$.

8. (a) Let $v = dy/dt$. Then

$$\frac{dv}{dt} = \frac{d^2y}{dt^2} = -2y.$$

Thus the associated vector field is $\mathbf{V}(y, v) = (v, -2y)$.

(b) See part (c).

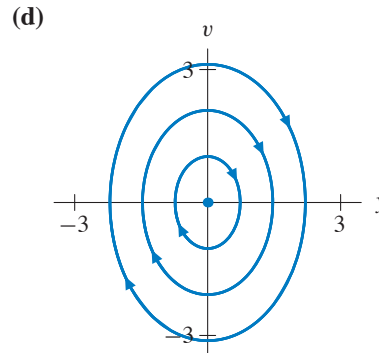
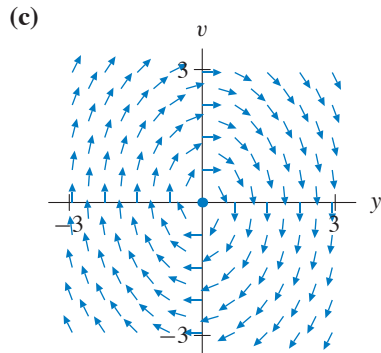

(e) As t increases, solutions move around the origin on ovals in the clockwise direction.

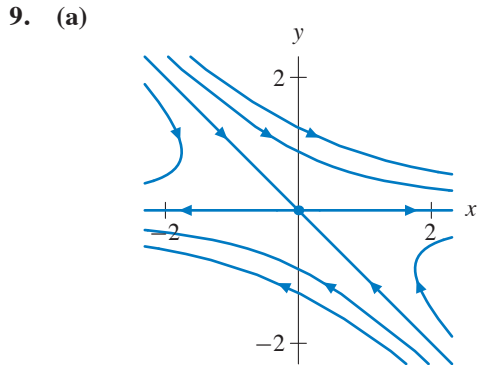

(b) The solution tends to the origin along the line $y = -x$ in the xy -phase plane. Therefore both $x(t)$ and $y(t)$ tend to zero as $t \rightarrow \infty$.

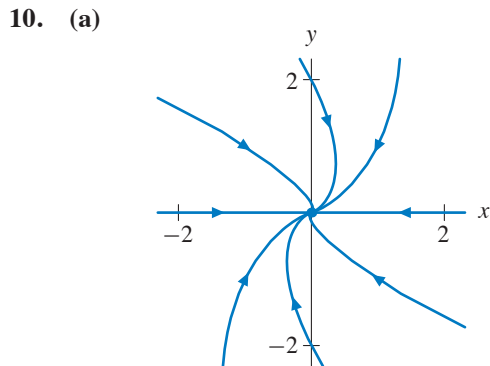

(b) The solution enters the first quadrant and tends to the origin tangent to the positive x -axis. Therefore $x(t)$ initially increases, reaches a maximum value, and then tends to zero as $t \rightarrow \infty$. It remains positive for all positive values of t . The function $y(t)$ decreases toward zero as $t \rightarrow \infty$.

11. (a) There are equilibrium points at $(\pm 1, 0)$, so only systems (ii) and (vii) are possible. Since the direction field points toward the x -axis if $y \neq 0$, the equation $dy/dt = y$ does not match this field. Therefore, system (vii) is the system that generated this direction field.
- (b) The origin is the only equilibrium point, so the possible systems are (iii), (iv), (v), and (viii). The direction field is not tangent to the y -axis, so it does not match either system (iv) or (v). Vectors point toward the origin on the line $y = x$, so $dy/dt = dx/dt$ if $y = x$. This condition is not satisfied by system (iii). Consequently, this direction field corresponds to system (viii).
- (c) The origin is the only equilibrium point, so the possible systems are (iii), (iv), (v), and (viii). Vectors point directly away from the origin on the y -axis, so this direction field does not correspond to systems (iii) and (viii). Along the line $y = x$, the vectors are more vertical than horizontal. Therefore, this direction field corresponds to system (v) rather than system (iv).
- (d) The only equilibrium point is $(1, 0)$, so the direction field must correspond to system (vi).
12. The equilibrium solutions are those solutions for which $dR/dt = 0$ and $dF/dt = 0$ simultaneously. To find the equilibrium points, we must solve the system of equations

$$\begin{cases} 2R\left(1 - \frac{R}{2}\right) - 1.2RF = 0 \\ -F + 0.9RF = 0. \end{cases}$$

The second equation is satisfied if $F = 0$ or if $R = 10/9$, and we consider each case independently. If $F = 0$, then the first equation is satisfied if and only if $R = 0$ or $R = 2$. Thus two equilibrium solutions are $(R, F) = (0, 0)$ and $(R, F) = (2, 0)$.

If $R = 10/9$, we substitute this value into the first equation and obtain $F = 20/27$.

13. (a) To find the equilibrium points, we solve the system of equations

$$\begin{cases} 4x - 7y + 2 = 0 \\ 3x + 6y - 1 = 0. \end{cases}$$

These simultaneous equations have one solution, $(x, y) = (-1/9, 2/9)$.

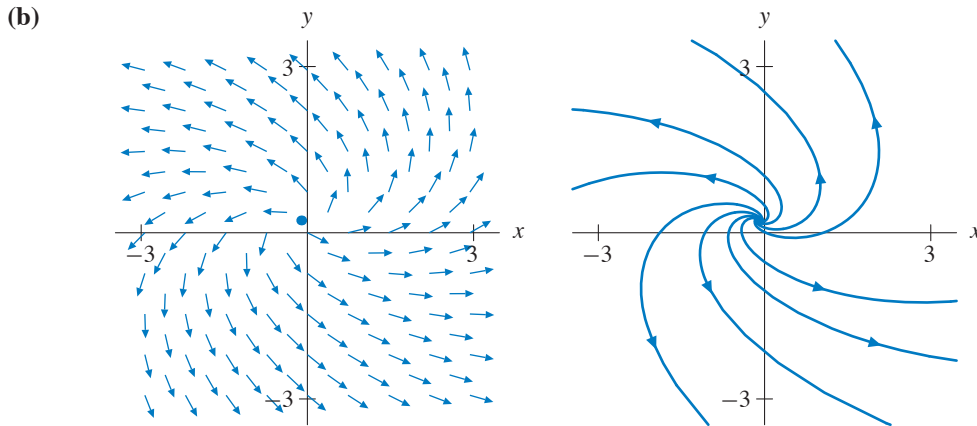

- (c) As t increases, typical solutions spiral away from the origin in the counter-clockwise direction.

14. (a) To find the equilibrium points, we solve the system of equations

$$\begin{cases} 4R - 7F - 1 = 0 \\ 3R + 6F - 12 = 0. \end{cases}$$

These simultaneous equations have one solution, $(R, F) = (2, 1)$.

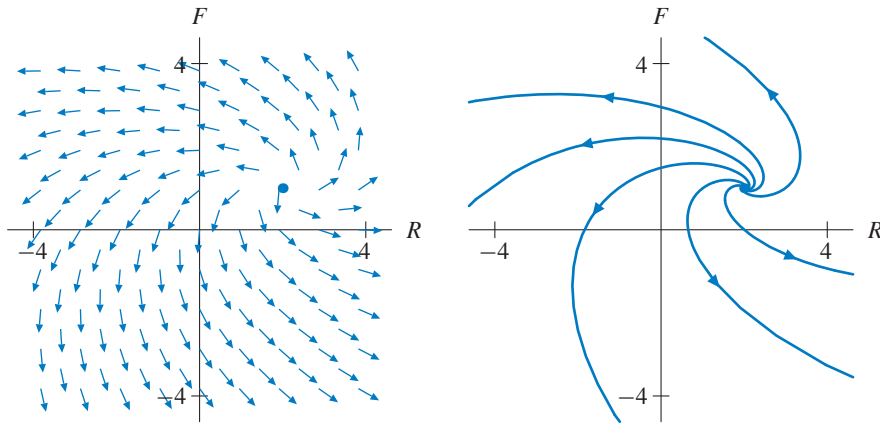

- (b) As t increases, typical solutions spiral away from the equilibrium point at $(2, 1)$

15. (a) To find the equilibrium points, we solve the system of equations

$$\begin{cases} \cos w = 0 \\ -z + w = 0. \end{cases}$$

The first equation implies that $w = \pi/2 + k\pi$ where k is any integer, and the second equation implies that $z = w$. The equilibrium points are $(\pi/2 + k\pi, \pi/2 + k\pi)$ for any integer k .

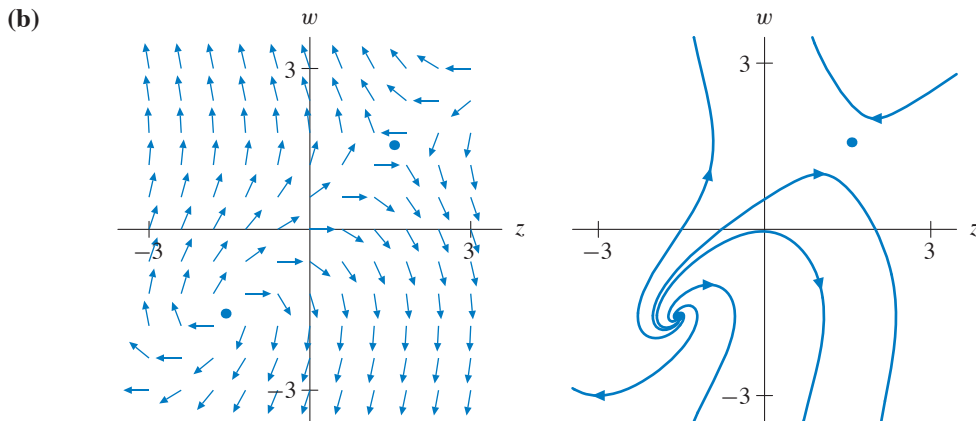

- (c) As t increases, typical solutions move away from the line $z = w$, which contains the equilibrium points. The value of w is either increasing or decreasing without bound depending on the initial condition.

16. (a) To find the equilibrium points, we solve the system of equations

$$\begin{cases} x - x^3 - y = 0 \\ y = 0. \end{cases}$$

Since $y = 0$, we have $x^3 - x = 0$. If we factor $x - x^3$ into $x(x - 1)(x + 1)$, we see that there are three equilibrium points, $(0, 0)$, $(1, 0)$, and $(-1, 0)$.

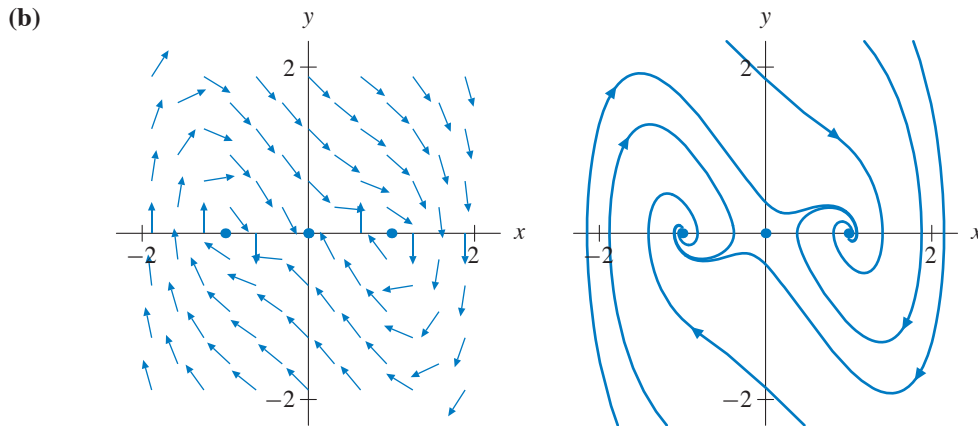

- (c) As t increases, typical solutions spiral toward either $(1, 0)$ or $(-1, 0)$ depending on the initial condition.

17. (a) To find the equilibrium points, we solve the system of equations

$$\begin{cases} y = 0 \\ -\cos x - y = 0. \end{cases}$$

We see that $y = 0$, and thus $\cos x = 0$. The equilibrium points are $(\pi/2 + k\pi, 0)$ for any integer k .

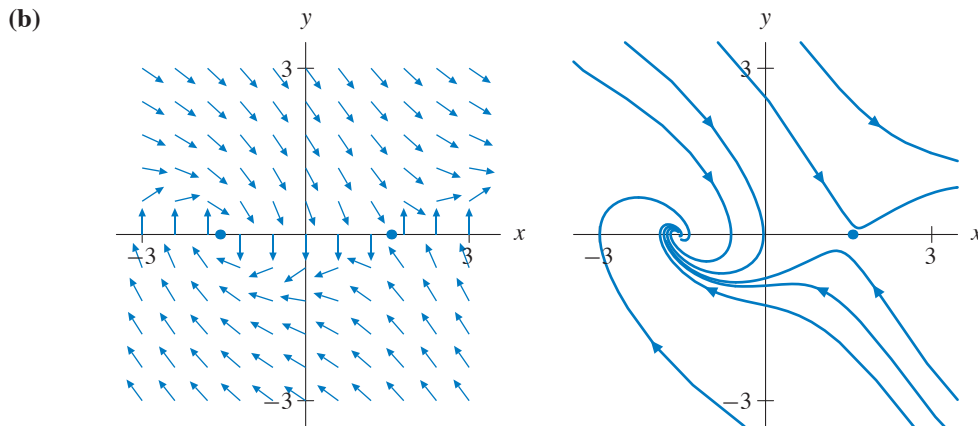

- (c) As t increases, typical solutions spiral toward one of the equilibria on the x -axis. Which equilibrium point the solution approaches depends on the initial condition.

18. (a) To find the equilibrium points, we solve the system of equations

$$\begin{cases} y(x^2 + y^2 - 1) = 0 \\ -x(x^2 + y^2 - 1) = 0. \end{cases}$$

If $x^2 + y^2 = 1$, then both equations are satisfied. Hence, any point on the unit circle centered at the origin is an equilibrium point. If $x^2 + y^2 \neq 1$, then the first equation implies $y = 0$ and the second equation implies $x = 0$. Hence, the origin is the only other equilibrium point.

- (b)

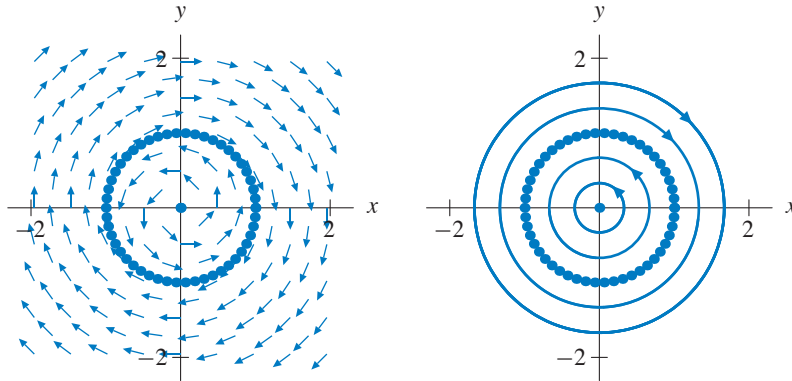

- (c) As t increases, typical solutions move on a circle around the origin, either counter-clockwise inside the unit circle, which consists entirely of equilibrium points, or clockwise outside the unit circle.

19. (a) Let $v = dx/dt$. Then

$$\frac{dv}{dt} = \frac{d^2x}{dt^2} = 3x - x^3 - 2v.$$

Thus the associated vector field is $\mathbf{V}(x, v) = (v, 3x - x^3 - 2v)$.

- (c)

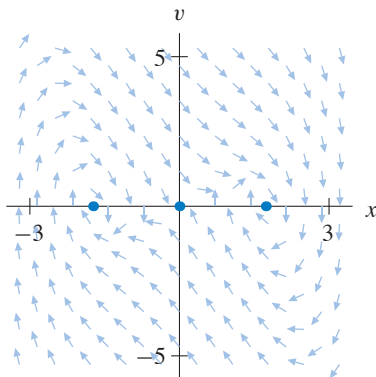

- (b) Setting $\mathbf{V}(x, v) = (0, 0)$ and solving for (x, v) , we get $v = 0$ and $3x - x^3 = 0$. Hence, the equilibria are $(x, v) = (0, 0)$ and $(x, v) = (\pm\sqrt{3}, 0)$.

- (d)

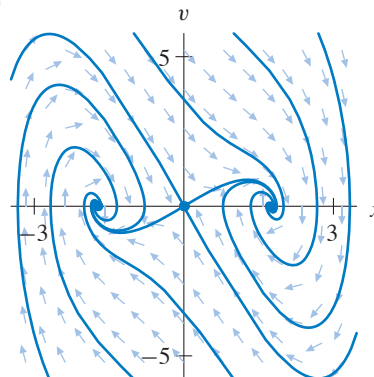

- (e) As t increases, almost all solutions spiral to one of the two equilibria $(\pm\sqrt{3}, 0)$. There is a curve of initial conditions that divides these two phenomena. It consists of those initial conditions for which the corresponding solutions tend to the equilibrium point at $(0, 0)$.

20. Consider a point (y, v) on the circle $y^2 + v^2 = r^2$. We can consider this point to be a radius vector—one that starts at the origin and ends at the point (y, v) . If we compute the dot product of this vector with the vector field $\mathbf{F}(y, v)$, we obtain

$$(y, v) \cdot \mathbf{F}(y, v) = (y, v) \cdot (v, -y) = yv - vy = 0.$$

Since the dot product of these two vectors is 0, the two vectors are perpendicular. Moreover, we know that any vector that is perpendicular to the radius vector of a circle must be tangent to that circle.

21. (a) The $x(t)$ - and $y(t)$ -graphs are periodic, so they correspond to a solution curve that returns to its initial condition in the phase plane. In other words, its solution curve is a closed curve. Since the amplitude of the oscillation of $x(t)$ is relatively large, these graphs must correspond to the outermost closed solution curve.

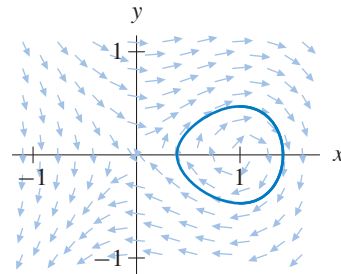

- (b) The graphs are not periodic, so they cannot correspond to the two closed solution curves in the phase portrait. Both graphs cross the t -axis. The value of $x(t)$ is initially negative, then becomes positive and reaches a maximum, and finally becomes negative again. Therefore, the corresponding solution curve is the one that starts in the second quadrant, then travels through the first and fourth quadrants, and finally enters the third quadrant.

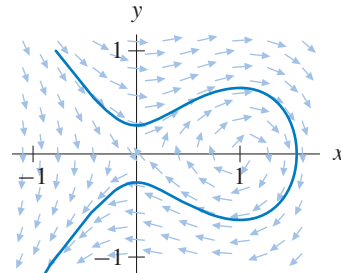

- (c) The graphs are not periodic, so they cannot correspond to the two closed solution curves in the phase portrait. Only one graph crosses the t -axis. The other graph remains negative for all time. Note that the two graphs cross.

The corresponding solution curve is the one that starts in the second quadrant and crosses the x -axis and the line $y = x$ as it moves through the third quadrant.

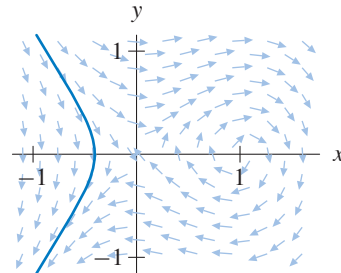

- (d) The $x(t)$ - and $y(t)$ -graphs are periodic, so they correspond to a solution curve that returns to its initial condition in the phase plane. In other words, its solution curve is a closed curve. Since the amplitude of the oscillation of $x(t)$ is relatively small, these graphs must correspond to the innermost closed solution curve.

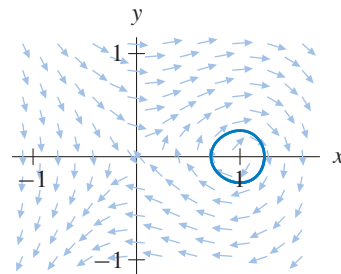

22. Often the solutions in the quiz are over a longer time interval than what is shown in the following graphs.

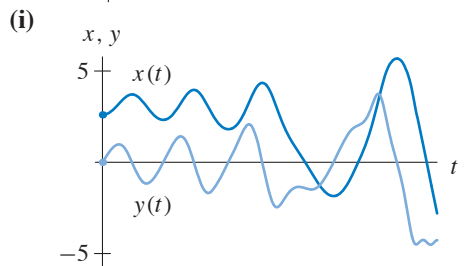
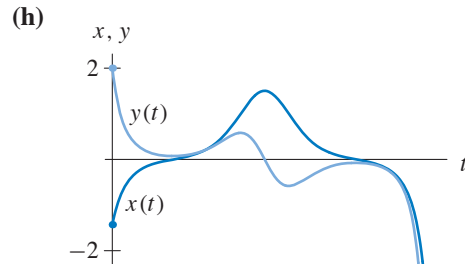
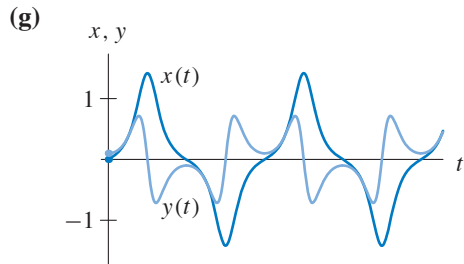
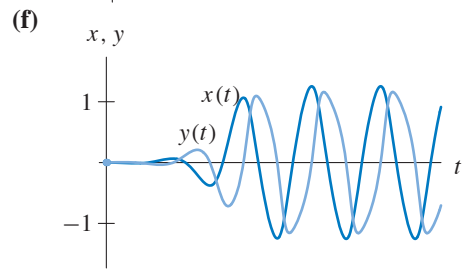
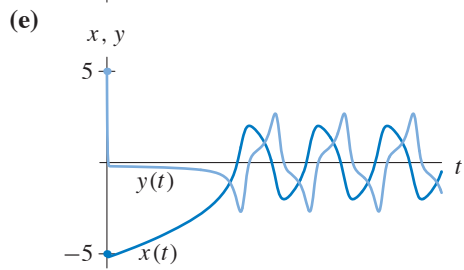
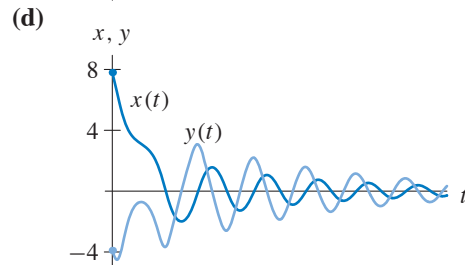
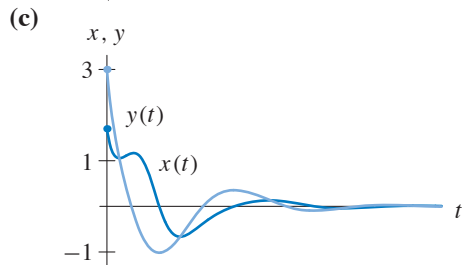
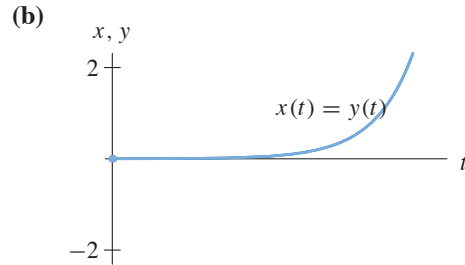
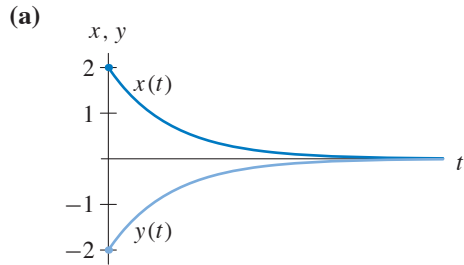

23. Since the solution curve spirals into the origin, the corresponding $x(t)$ - and $y(t)$ -graphs must oscillate about the t -axis with the decreasing amplitudes.

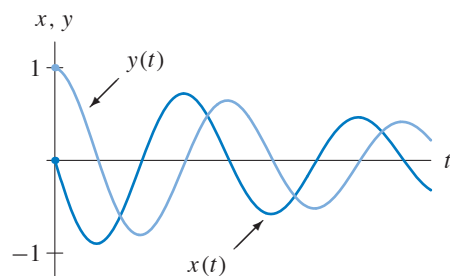

24. Since the solution curve is an ellipse that is centered at $(2, 1)$, the $x(t)$ - and $y(t)$ -graphs are periodic. They oscillate about the lines $x = 2$ and $y = 1$.

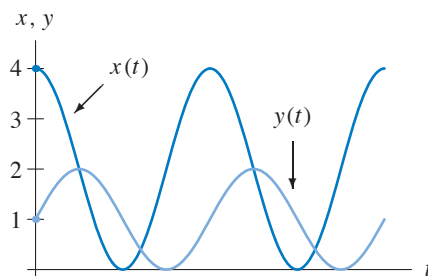

25. The $x(t)$ -graph satisfies $-2 < x(0) < -1$ and increases as t increases. The $y(t)$ -graph satisfies $1 < y(0) < 2$. Initially it decreases until it reaches its minimum value of $y = 1$ when $x = 0$. Then it increases as t increases.

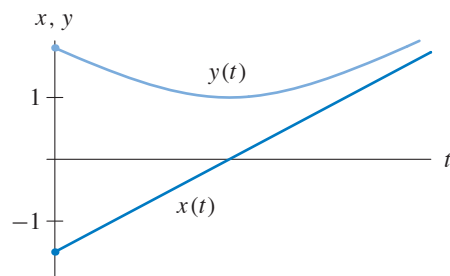

26. The $x(t)$ -graph starts with a small positive value and increases as t increases. The $y(t)$ -graph starts at approximately 1.6 and decreases as t increases. However, $y(t)$ remains positive for all t .

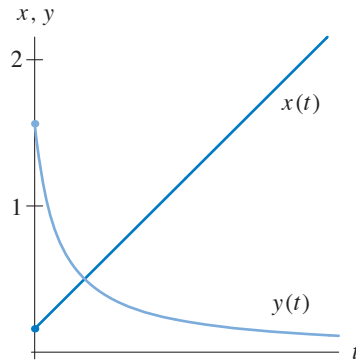

27. From the graphs, we see that $y(0) = 0$ and $x(0)$ is slightly positive. Initially both graphs increase. Then they cross, and slightly later $x(t)$ attains its maximum value. Continuing along we see that $y(t)$ attains its maximum at the same time as $x(t)$ crosses the t -axis.

In the xy -phase plane these graphs correspond to a solution curve that starts on the positive x -axis, enters the first quadrant, crosses the line $y = x$, and eventually crosses the y -axis into the second quadrant exactly when $y(t)$ assumes its maximum value. For this portion of the curve, $y(t)$ is increasing while $x(t)$ assumes a maximum and starts decreasing.

We see that once $y(t)$ attains its maximum, it decreases for a prolonged period of time until it assumes its minimum value. Throughout this interval, $x(t)$ remains negative although it assumes its minimum value twice and a local maximum value once. In the phase plane, the solution curve enters the second quadrant and then crosses into the third quadrant when $y(t) = 0$. The $x(t)$ - and $y(t)$ -graphs cross precisely when the solution curve crosses the line $y = x$ in the third quadrant.

Finally the $y(t)$ -graph is increasing again while the $x(t)$ -graph becomes positive and assumes its maximum value once more. The two graphs return to their initial values. In the phase plane this behavior corresponds to the solution curve moving from the third quadrant through the fourth quadrant and back to the original starting point.

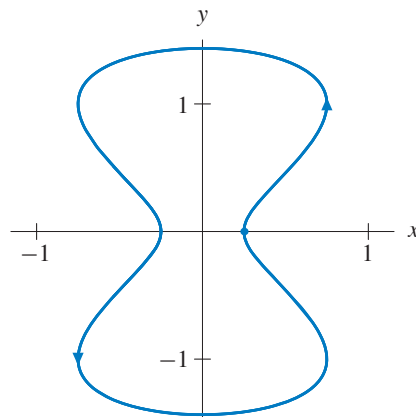

EXERCISES FOR SECTION 2.3

1. (a) See part (c).
 (b) We guess that there are solutions of the form $y(t) = e^{st}$ for some choice of the constant s . To determine these values of s , we substitute $y(t) = e^{st}$ into the left-hand side of the differential equation, obtaining

$$\begin{aligned} \frac{d^2y}{dt^2} + 7\frac{dy}{dt} + 10y &= \frac{d^2(e^{st})}{dt^2} + 7\frac{d(e^{st})}{dt} + 10(e^{st}) \\ &= s^2e^{st} + 7se^{st} + 10e^{st} \\ &= (s^2 + 7s + 10)e^{st} \end{aligned}$$

In order for $y(t) = e^{st}$ to be a solution, this expression must be 0 for all t . In other words,

$$s^2 + 7s + 10 = 0.$$

This equation is satisfied only if $s = -2$ or $s = -5$. We obtain two solutions, $y_1(t) = e^{-2t}$ and $y_2(t) = e^{-5t}$, of this equation.

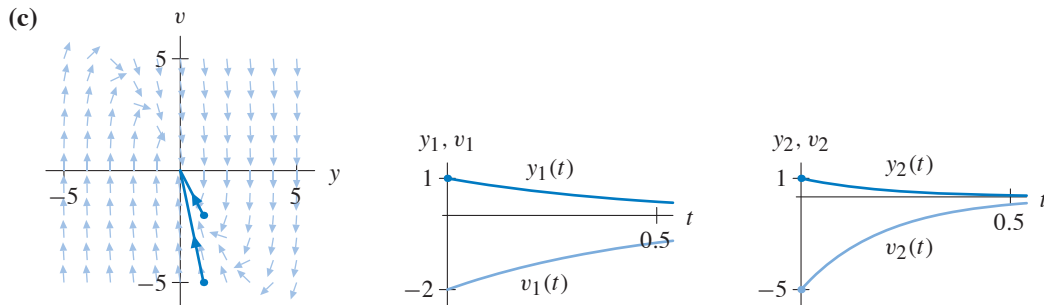

2. (a) See part (c).
 (b) We guess that there are solutions of the form $y(t) = e^{st}$ for some choice of the constant s . To determine these values of s , we substitute $y(t) = e^{st}$ into the left-hand side of the differential equation, obtaining

$$\begin{aligned} \frac{d^2y}{dt^2} + 5\frac{dy}{dt} + 6y &= \frac{d^2(e^{st})}{dt^2} + 5\frac{d(e^{st})}{dt} + 6(e^{st}) \\ &= s^2e^{st} + 5se^{st} + 6e^{st} \\ &= (s^2 + 5s + 6)e^{st} \end{aligned}$$

In order for $y(t) = e^{st}$ to be a solution, this expression must be 0 for all t . In other words,

$$s^2 + 5s + 6 = 0.$$

This equation is satisfied only if $s = -3$ or $s = -2$. We obtain two solutions, $y_1(t) = e^{-3t}$ and $y_2(t) = e^{-2t}$, of this equation.

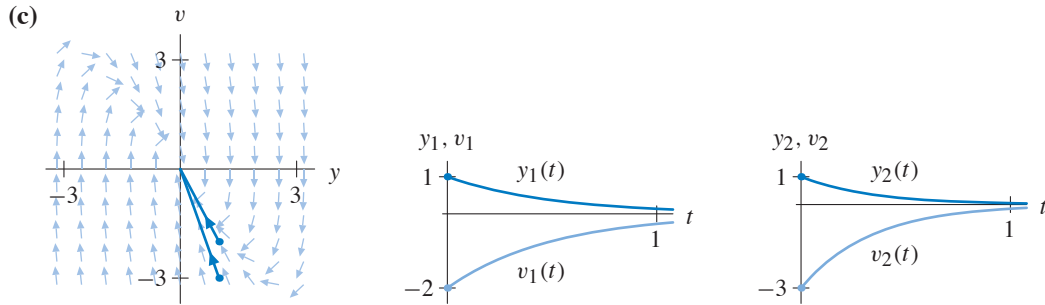

3. (a) See part (c).

(b) We guess that there are solutions of the form $y(t) = e^{st}$ for some choice of the constant s . To determine these values of s , we substitute $y(t) = e^{st}$ into the left-hand side of the differential equation, obtaining

$$\begin{aligned} \frac{d^2y}{dt^2} + 4\frac{dy}{dt} + y &= \frac{d^2(e^{st})}{dt^2} + 4\frac{d(e^{st})}{dt} + e^{st} \\ &= s^2e^{st} + 4se^{st} + e^{st} \\ &= (s^2 + 4s + 1)e^{st} \end{aligned}$$

In order for $y(t) = e^{st}$ to be a solution, this expression must be 0 for all t . In other words,

$$s^2 + 4s + 1 = 0.$$

Applying the quadratic formula, we obtain the roots $s = -2 \pm \sqrt{3}$ and the two solutions, $y_1(t) = e^{(-2-\sqrt{3})t}$ and $y_2(t) = e^{(-2+\sqrt{3})t}$, of this equation.

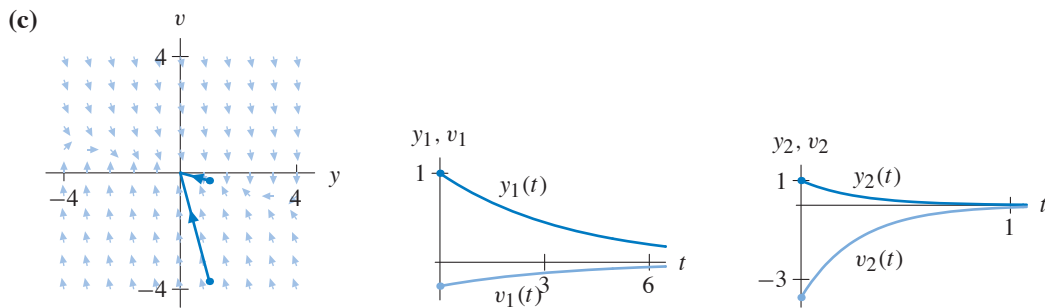

4. (a) See part (c).

(b) We guess that there are solutions of the form $y(t) = e^{st}$ for some choice of the constant s . To determine these values of s , we substitute $y(t) = e^{st}$ into the left-hand side of the differential equation, obtaining

$$\begin{aligned} \frac{d^2y}{dt^2} + 6\frac{dy}{dt} + 7y &= \frac{d^2(e^{st})}{dt^2} + 6\frac{d(e^{st})}{dt} + 7e^{st} \\ &= s^2e^{st} + 6se^{st} + 7e^{st} \\ &= (s^2 + 6s + 7)e^{st} \end{aligned}$$

In order for $y(t) = e^{st}$ to be a solution, this expression must be 0 for all t . In other words,

$$s^2 + 6s + 7 = 0.$$

Applying the quadratic formula, we obtain the roots $s = -3 \pm \sqrt{2}$ and the two solutions, $y_1(t) = e^{(-3-\sqrt{2})t}$ and $y_2(t) = e^{(-3+\sqrt{2})t}$, of this equation.

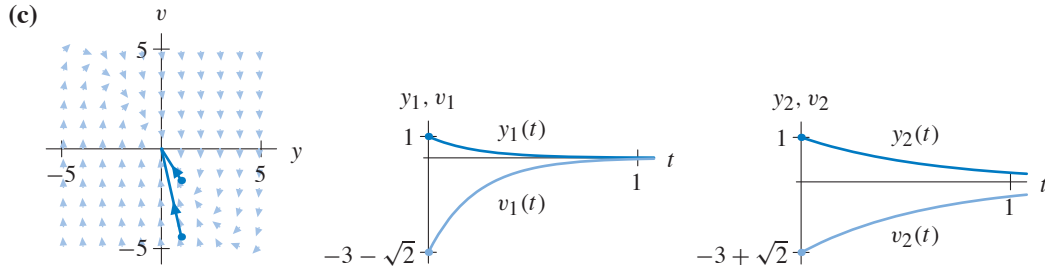

5. (a) See part (c).
 (b) We guess that there are solutions of the form $y(t) = e^{st}$ for some choice of the constant s . To determine these values of s , we substitute $y(t) = e^{st}$ into the left-hand side of the differential equation, obtaining

$$\begin{aligned} \frac{d^2y}{dt^2} + 3\frac{dy}{dt} - 10y &= \frac{d^2(e^{st})}{dt^2} + 3\frac{d(e^{st})}{dt} - 10(e^{st}) \\ &= s^2e^{st} + 3se^{st} - 10e^{st} \\ &= (s^2 + 3s - 10)e^{st} \end{aligned}$$

In order for $y(t) = e^{st}$ to be a solution, this expression must be 0 for all t . In other words,

$$s^2 + 3s - 10 = 0.$$

This equation is satisfied only if $s = -5$ or $s = 2$. We obtain two solutions, $y_1(t) = e^{-5t}$ and $y_2(t) = e^{2t}$, of this equation.

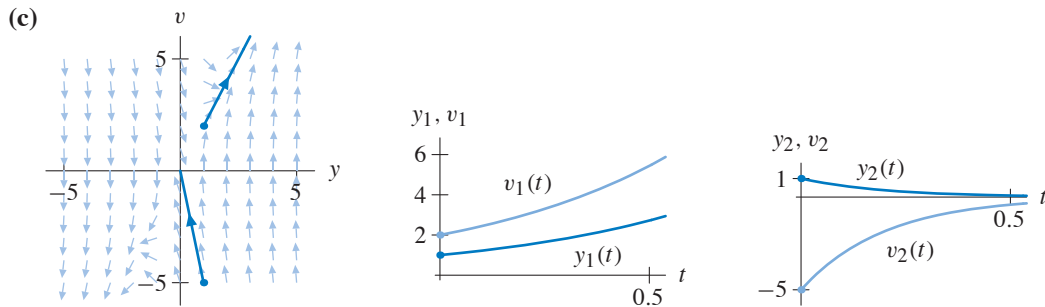

6. (a) See part (c).
 (b) We guess that there are solutions of the form $y(t) = e^{st}$ for some choice of the constant s . To determine these values of s , we substitute $y(t) = e^{st}$ into the left-hand side of the differential equation, obtaining

$$\begin{aligned} \frac{d^2y}{dt^2} + \frac{dy}{dt} - 2y &= \frac{d^2(e^{st})}{dt^2} + \frac{d(e^{st})}{dt} - 2(e^{st}) \\ &= s^2e^{st} + se^{st} - 2e^{st} \\ &= (s^2 + s - 2)e^{st} \end{aligned}$$

In order for $y(t) = e^{st}$ to be a solution, this expression must be 0 for all t . In other words,

$$s^2 + s - 2 = 0.$$

This equation is satisfied only if $s = -2$ or $s = 1$. We obtain two solutions, $y_1(t) = e^{-2t}$ and $y_2(t) = e^t$, of this equation.

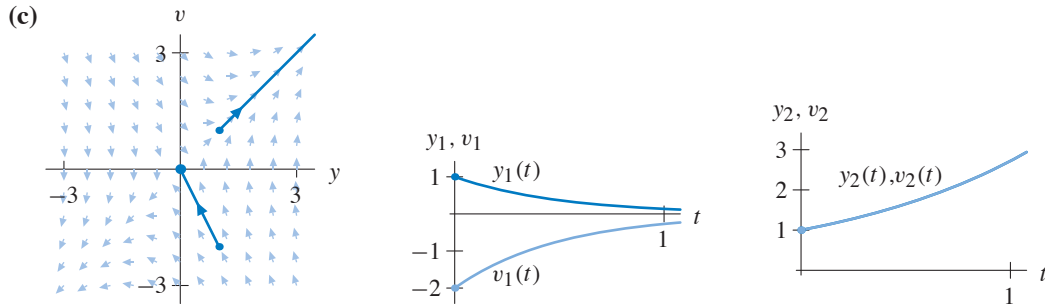

7. (a) Let $y_p(t)$ be any solution of the damped harmonic oscillator equation and $y_g(t) = \alpha y_p(t)$ where α is a constant. We substitute $y_g(t)$ into the left-hand side of the damped harmonic oscillator equation, obtaining

$$\begin{aligned} m \frac{d^2y}{dt^2} + b \frac{dy}{dt} + ky &= m \frac{d^2y_g}{dt^2} + b \frac{dy_g}{dt} + ky_g \\ &= m\alpha \frac{d^2y_p}{dt^2} + b\alpha \frac{dy_p}{dt} + \alpha ky_p \\ &= \alpha \left(m \frac{d^2y_p}{dt^2} + b \frac{dy_p}{dt} + ky_p \right) \end{aligned}$$

Since $y_p(t)$ is a solution, we know that the expression in the parentheses is zero. Therefore, $y_g(t) = \alpha y_p(t)$ is a solution of the damped harmonic oscillator equation.

- (b) Substituting $y(t) = \alpha e^{-t}$ into the left-hand side of the damped harmonic oscillator equation, we obtain

$$\frac{d^2y}{dt^2} + 3 \frac{dy}{dt} + 2y = \frac{d^2(\alpha e^{-t})}{dt^2} + 3 \frac{d(\alpha e^{-t})}{dt} + 2(\alpha e^{-t})$$

$$\begin{aligned}
&= \alpha e^{-t} - 3\alpha e^{-t} + 2\alpha e^{-t} \\
&= (\alpha - 3\alpha + 2\alpha)e^{-t} \\
&= 0.
\end{aligned}$$

We also get zero if we substitute $y(t) = \alpha e^{-2t}$ into the equation.

- (c) If we obtain one nonzero solution to the equation with the guess-and-test method, then we obtain an infinite number of solutions because there are infinitely many constants α .
8. (a) Let $y_1(t)$ and $y_2(t)$ be any two solutions of the damped harmonic oscillator equation. We substitute $y_1(t) + y_2(t)$ into the left-hand side of the equation, obtaining

$$\begin{aligned}
m \frac{d^2 y}{dt^2} + b \frac{dy}{dt} + ky &= m \frac{d^2(y_1 + y_2)}{dt^2} + b \frac{d(y_1 + y_2)}{dt} + k(y_1 + y_2) \\
&= \left(m \frac{d^2 y_1}{dt^2} + b \frac{dy_1}{dt} + ky_1 \right) + \left(m \frac{d^2 y_2}{dt^2} + b \frac{dy_2}{dt} + ky_2 \right) \\
&= 0 + 0 = 0
\end{aligned}$$

because $y_1(t)$ and $y_2(t)$ are solutions.

- (b) In the section, we saw that $y_1(t) = e^{-t}$ and $y_2(t) = e^{-2t}$ are two solutions to this differential equation. Note that the $y_1(0) + y_2(0) = 2$ and $v_1(0) + v_2(0) = -3$. Consequently, $y(t) = y_1(t) + y_2(t)$, that is, $y(t) = e^{-t} + e^{-2t}$, is the solution of the initial-value problem.
- (c) If we combine the result of part (a) of Exercise 7 with the result in part (a) of this exercise, we see that any function of the form

$$y(t) = \alpha e^{-t} + \beta e^{-2t}$$

is a solution if α and β are constants. Evaluating $y(t)$ and $v(t) = y'(t)$ at $t = 0$ yields the two equations

$$\begin{aligned}
\alpha + \beta &= 3 \\
-\alpha - 2\beta &= -5.
\end{aligned}$$

We obtain $\alpha = 1$ and $\beta = 2$. The desired solution is $y(t) = e^{-t} + 2e^{-2t}$.

- (d) Given that any constant multiple of a solution yields another solution and that the sum of any two solutions yields another solution, we see that all functions of the form

$$y(t) = \alpha e^{-t} + \beta e^{-2t}$$

where α and β are constants are solutions. Therefore, we obtain an infinite number of solutions to this equation.

9. We choose the left wall to be the position $x = 0$ with $x > 0$ indicating positions to the right. Each spring exerts a force on the mass. If the position of the mass is x , then the left spring is stretched by the amount $x - L_1$. Therefore, the force F_1 exerted by this spring is

$$F_1 = k_1(L_1 - x).$$

Similarly, the right spring is stretched by the amount $(1 - x) - L_2$. However, the restoring force F_2 of the right spring acts in the direction of increasing values of x . Therefore, we have

$$F_2 = k_2 ((1 - x) - L_2).$$

Using Newton's second law, we have

$$m \frac{d^2x}{dt^2} = k_1 (L_1 - x) + k_2 ((1 - x) - L_2) - b \frac{dx}{dt},$$

where the term involving dx/dt represents the force due to damping. After a little algebra, we obtain

$$m \frac{d^2x}{dt^2} + b \frac{dx}{dt} + (k_1 + k_2)x = k_1 L_1 - k_2 L_2 + k_2.$$

10. (a) Let $v = dx/dt$ as usual. From Exercise 9, we have

$$\begin{aligned} \frac{dx}{dt} &= v \\ \frac{dv}{dt} &= -\frac{k_1 + k_2}{m}x - \frac{b}{m}v + \frac{C}{m} \end{aligned}$$

where C is the constant $k_1 L_1 - k_2 L_2 + k_2$.

- (b) To find the equilibrium points, we set $dx/dt = 0$ and obtain $v = 0$. Setting $dv/dt = 0$ with $v = 0$, we obtain

$$(k_1 + k_2)x = C.$$

Therefore, this system has one equilibrium point,

$$(x_0, v_0) = \left(\frac{C}{k_1 + k_2}, 0 \right).$$

- (c) We change coordinates so that the origin corresponds to this equilibrium point. In other words, we reexpress the system in terms of the new variable $y = x - x_0$. Since $dy/dt = dx/dt = v$, we have

$$\begin{aligned} \frac{dv}{dt} &= -\frac{k_1 + k_2}{m}x - \frac{b}{m}v + \frac{C}{m} \\ &= -\frac{k_1 + k_2}{m}(y + x_0) - \frac{b}{m}v + \frac{C}{m} \\ &= -\frac{k_1 + k_2}{m}y - \frac{C}{m} - \frac{b}{m}v + \frac{C}{m}, \end{aligned}$$

since $(k_1 + k_2)x_0 = C$. In terms of y and v , we have

$$\begin{aligned} \frac{dy}{dt} &= v \\ \frac{dv}{dt} &= -\frac{k_1 + k_2}{m}y - \frac{b}{m}v. \end{aligned}$$

- (d) In terms of y and v , this system is exactly the same as a damped harmonic oscillator with spring constant $k = k_1 + k_2$ and damping coefficient b .

EXERCISES FOR SECTION 2.4

1. To check that $dx/dt = 2x + 2y$, we compute both

$$\frac{dx}{dt} = 2e^t$$

and

$$2x + 2y = 4e^t - 2e^t = 2e^t.$$

To check that $dy/dt = x + 3y$, we compute both

$$\frac{dy}{dt} = -e^t,$$

and

$$x + 3y = 2e^t - 3e^t = -e^t.$$

Both equations are satisfied for all t . Hence $(x(t), y(t))$ is a solution.

2. To check that $dx/dt = 2x + 2y$, we compute both

$$\frac{dx}{dt} = 6e^{2t} + e^t$$

and

$$2x + 2y = 6e^{2t} + 2e^t - 2e^t + 2e^{4t} = 6e^{2t} + 2e^{4t}.$$

Since the results of these two calculations do not agree, the first equation in the system is not satisfied, and $(x(t), y(t))$ is not a solution.

3. To check that $dx/dt = 2x + 2y$, we compute both

$$\frac{dx}{dt} = 2e^t - 4e^{4t}$$

and

$$2x + 2y = 4e^t - 2e^{4t} - 2e^t + 2e^{4t} = 2e^t.$$

Since the results of these two calculations do not agree, the first equation in the system is not satisfied, and $(x(t), y(t))$ is not a solution.

4. To check that $dx/dt = 2x + 2y$, we compute both

$$\frac{dx}{dt} = 4e^t + 4e^{4t}$$

and

$$2x + 2y = 8e^t + 2e^{4t} - 4e^t + 2e^{4t} = 4e^t + 4e^{4t}.$$

To check that $dy/dt = x + 3y$, we compute both

$$\frac{dy}{dt} = -2e^t + 4e^{4t},$$

and

$$x + 3y = 4e^t + e^{4t} - 6e^t + 3e^{4t} = -2e^t + 4e^{4t}.$$

Both equations are satisfied for all t . Hence $(x(t), y(t))$ is a solution.

5. The second equation in the system is $dy/dt = -y$, and from Section 1.1, we know that $y(t)$ must be a function of the form y_0e^{-t} , where y_0 is the initial value.
6. Yes. You can always show that a given function is a solution by verifying the equations directly (as in Exercises 1–4).

To check that $dx/dt = 2x + y$, we compute both

$$\frac{dx}{dt} = 8e^{2t} + e^{-t}$$

and

$$2x + y = 8e^{2t} - 2e^{-t} + 3e^{-t} = 8e^{2t} + e^{-t}.$$

To check that $dy/dt = -y$, we compute both

$$\frac{dy}{dt} = -3e^{-t},$$

and

$$-y = -3e^{-t}.$$

Both equations are satisfied for all t . Hence $(x(t), y(t))$ is a solution.

7. From the second equation, we know that $y(t) = k_1e^{-t}$ for some constant k_1 . Using this observation, the first equation in the system can be rewritten as

$$\frac{dx}{dt} = 2x + k_1e^{-t}.$$

This equation is a first-order linear equation, and we can derive the general solution using the Extended Linearity Principle from Section 1.8 or integrating factors from Section 1.9.

Using the Extended Linearity Principle, we note that the general solution of the associated homogeneous equation is $x_h(t) = k_2e^{2t}$.

To find one solution to the nonhomogeneous equation, we guess $x_p(t) = \alpha e^{-t}$. Then

$$\begin{aligned} \frac{dx_p}{dt} - 2x_p &= -\alpha e^{-t} - 2\alpha e^{-t} \\ &= -3\alpha e^{-t}. \end{aligned}$$

Therefore, $x_p(t)$ is a solution if $\alpha = -k_1/3$.

The general solution for $x(t)$ is

$$x(t) = k_2e^{2t} - \frac{k_1}{3}e^{-t}.$$

8. (a) No. Given the general solution

$$\left(k_2e^{2t} - \frac{k_1}{3}e^{-t}, k_1e^{-t} \right),$$

the function $y(t) = 3e^{-t}$ implies that $k_1 = 3$. But this choice of k_1 implies that the coefficient of e^{-t} in the formula for $x(t)$ is -1 rather than $+1$.

(b) To determine that $\mathbf{Y}(t)$ is not a solution without reference to the general solution, we check the equation $dx/dt = 2x + y$. We compute both

$$\frac{dx}{dt} = -e^{-t}$$

and

$$2x + y = 2e^{-t} + 3e^{-t}.$$

Since these two functions are not equal, $\mathbf{Y}(t)$ is not a solution.

9. (a) Given the general solution

$$\left(k_2 e^{2t} - \frac{k_1}{3} e^{-t}, k_1 e^{-t}\right),$$

we see that $k_1 = 0$, and therefore $k_2 = 1$. We obtain $\mathbf{Y}(t) = (x(t), y(t)) = (e^{2t}, 0)$.

(b)

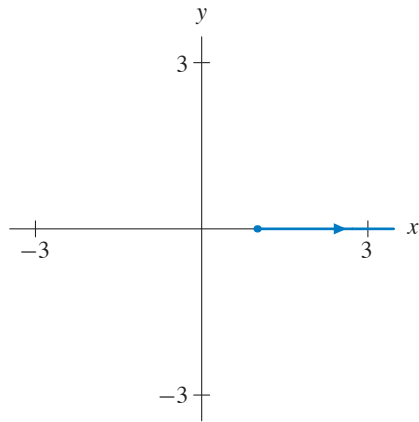

(c)

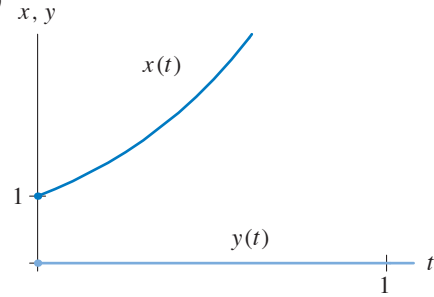

10. (a) Given the general solution

$$\left(k_2 e^{2t} - \frac{k_1}{3} e^{-t}, k_1 e^{-t}\right),$$

we see that $k_1 = 3$, and therefore $k_2 = 0$. We obtain $\mathbf{Y}(t) = (x(t), y(t)) = (-e^{-t}, 3e^{-t})$.

(b)

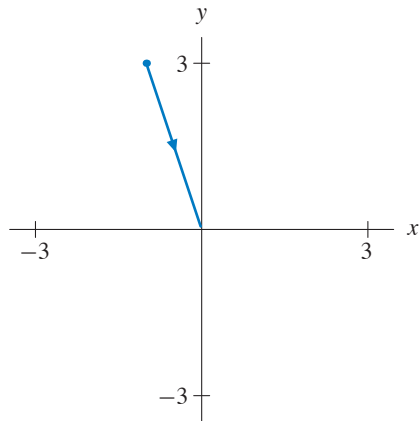

(c)

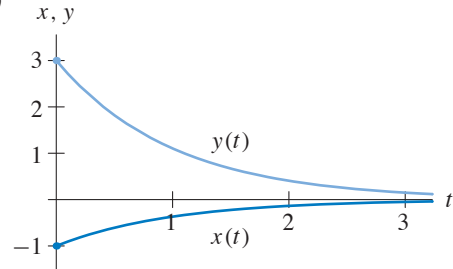

11. (a) Given the general solution

$$\left(k_2 e^{2t} - \frac{k_1}{3} e^{-t}, k_1 e^{-t}\right),$$

we see that $k_1 = 1$, and therefore $k_2 = 1/3$. We obtain

$$\mathbf{Y}(t) = (x(t), y(t)) = \left(\frac{1}{3}e^{2t} - \frac{1}{3}e^{-t}, e^{-t}\right).$$

(b)

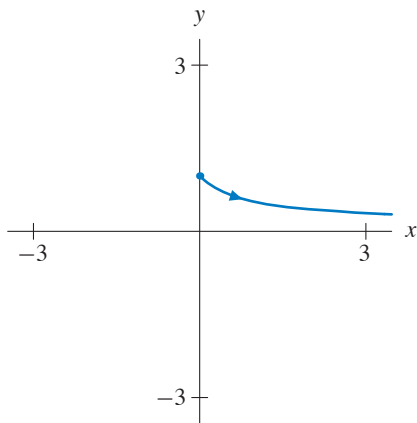

(c)

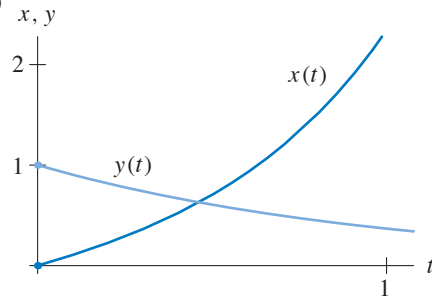

12. (a) Given the general solution

$$\left(k_2 e^{2t} - \frac{k_1}{3} e^{-t}, k_1 e^{-t}\right),$$

we see that $k_1 = -1$, and therefore $k_2 = 2/3$. We obtain

$$\mathbf{Y}(t) = (x(t), y(t)) = \left(\frac{2}{3}e^{2t} + \frac{1}{3}e^{-t}, -e^{-t}\right).$$

(b)

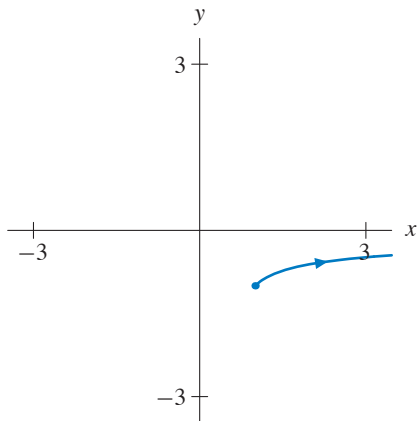

(c)

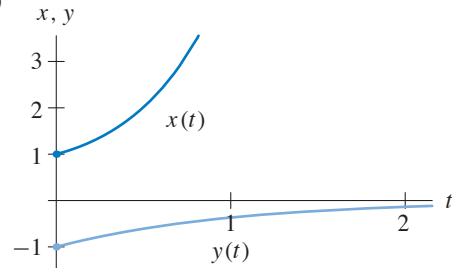

13. (a) For this system, we note that the equation for \bar{y}/dt is a homogeneous linear equation. Its general solution is

$$y(t) = k_2 e^{-3t}.$$

Substituting $y = k_2 e^{-3t}$ into the equation for dx/dt , we have

$$\begin{aligned}\frac{dx}{dt} &= 2x - 8(k_2 e^{-3t})^2 \\ &= 2x - 8k_2^2 e^{-6t}\end{aligned}$$

This equation is a linear and nonhomogeneous. The general solution of the associated homogeneous equation is $x_h(t) = k_1 e^{2t}$. To find one particular solution of the nonhomogeneous equation, we guess

$$x_p(t) = \alpha e^{-6t}.$$

With this guess, we have

$$\begin{aligned}\frac{dx_p}{dt} - 2x_p &= -6\alpha e^{-6t} - 2\alpha e^{-6t} \\ &= -8\alpha e^{-6t}.\end{aligned}$$

Therefore, $x_p(t)$ is a solution if $\alpha = k_2^2$. The general solution for $x(t)$ is $k_1 e^{2t} + k_2^2 e^{-6t}$, and the general solution for the system is

$$(x(t), y(t)) = (k_1 e^{2t} + k_2^2 e^{-6t}, k_2 e^{-3t}).$$

- (b) Setting $dy/dt = 0$, we obtain $y = 0$. From $dx/dt = 2x - 8y^2 = 0$, we see that $x = 0$ as well. Therefore, this system has exactly one equilibrium point, $(x, y) = (0, 0)$.
- (c) If $(x(0), y(0)) = (0, 1)$, then $k_2 = 1$. We evaluate the expression for $x(t)$ at $t = 0$ and obtain $k_1 + 1 = 0$. Consequently, $k_1 = -1$, and the solution to the initial-value problem is

$$(x(t), y(t)) = (e^{-6t} - e^{2t}, e^{-3t}).$$

(d)

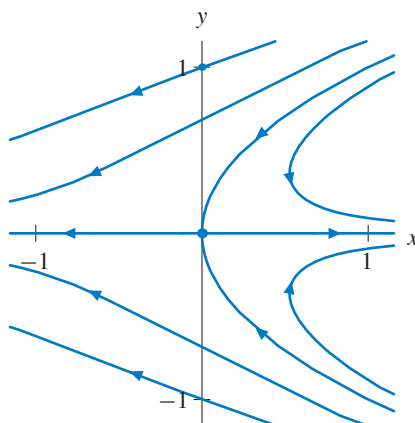

EXERCISES FOR SECTION 2.5

1. (a) We compute

$$\frac{dx}{dt} = \frac{d(\cos t)}{dt} = -\sin t = -y \quad \text{and} \quad \frac{dy}{dt} = \frac{d(\sin t)}{dt} = \cos t = x,$$

so $(\cos t, \sin t)$ is a solution.

- (b)

Table 2.1

t	Euler's approx.	actual	distance
0	(1, 0)	(1, 0)	
4	(-2.06, -1.31)	(-0.65, -0.76)	1.51
6	(2.87, -2.51)	(0.96, -0.28)	2.94
10	(-9.21, 1.41)	(-0.84, -0.54)	8.59

- (c)

Table 2.2

t	Euler's approx.	actual	distance
0	(1, 0)	(1, 0)	
4	(-.81, -.91)	(-0.65, -0.76)	0.22
6	(1.29, -.40)	(0.96, -0.28)	0.35
10	(-1.41, -.85)	(-0.84, -.54)	0.65

- (d) The solution curves for this system are all circles centered at the origin. Since Euler's method uses tangent lines to approximate the solution curve and the tangent line to any point on a circle is entirely outside the circle (except at the point of tangency), each step of the Euler approximation takes the approximate solution farther from the origin. So the Euler approximations always spiral away from the origin for this system.

2. (a) We compute

$$\frac{dx}{dt} = \frac{d(e^{2t})}{dt} = 2e^{2t} = 2x \quad \text{and} \quad \frac{dy}{dt} = \frac{d(3e^t)}{dt} = 3e^t = y,$$

so $(e^{2t}, 3e^t)$ is a solution.

- (b)

Table 2.3

t	Euler's approx.	actual	distance
0	(1, 3)	(1, 3)	
2	(16, 15.1875)	(54.59, 22.17)	39.22
4	(256, 76.88)	(2981, 164)	2726
6	(4096, 389)	(162755, 1210)	158661

(c)

Table 2.4

t	Euler's approx.	actual	distance
0	(1, 3)	(1, 3)	
2	(38.34, 20.18)	(54.59, 22.17)	16.38
4	(1470, 136)	(2981, 164)	1511.4
6	(56347, 913)	(162755, 1210)	106408

(d) The solution curve starts at (1, 3) and tends to infinity in both the x - and y -directions. Because the solution is an exponential, Euler's method has a hard time keeping up with the growth of the solutions.

3. (a) Euler approximation yields $(x_5, y_5) \approx (0.65, -0.59)$.

(b)

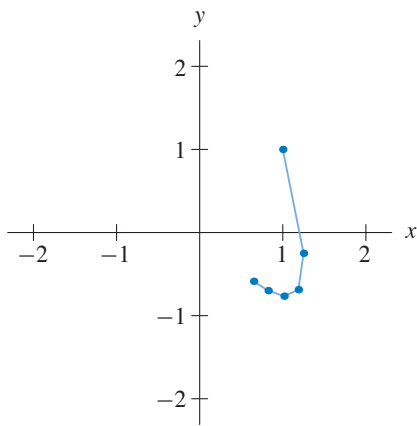

(c)

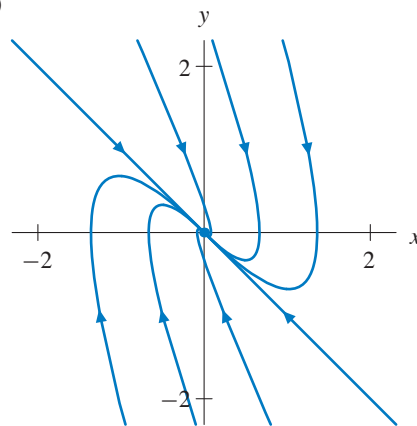

4. (a) Euler approximation yields $(x_8, y_8) \approx (3.00, 0.76)$.

(b)

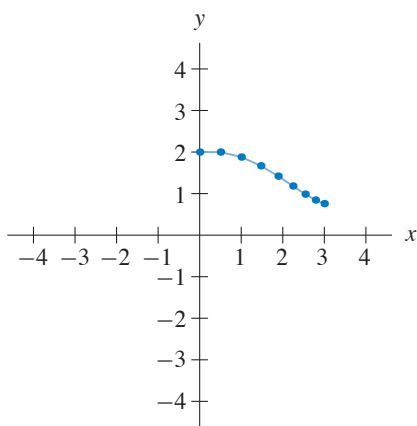

(c)

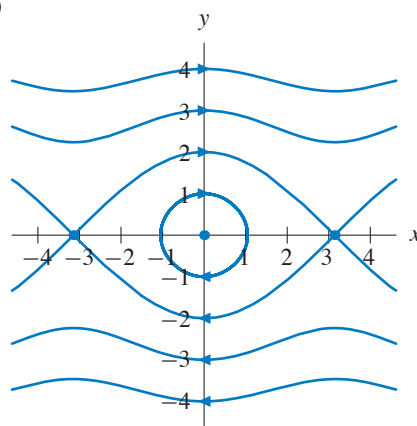

5. (a) Euler approximation yields $(x_5, y_5) \approx (1.94, -0.72)$.

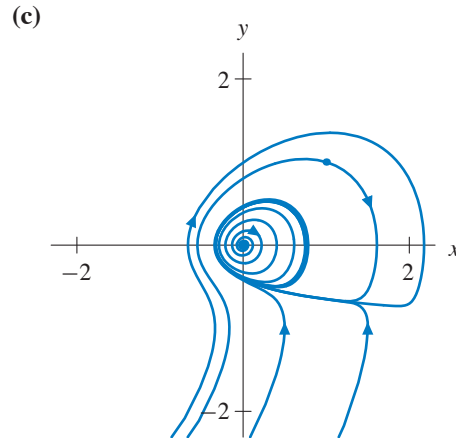
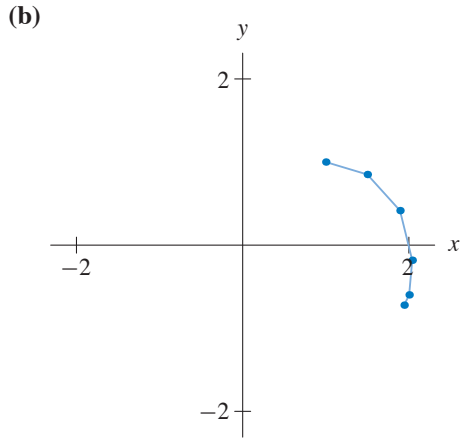

6. (a) Euler approximation yields $(x_7, y_7) \approx (0.15, 0.78)$.

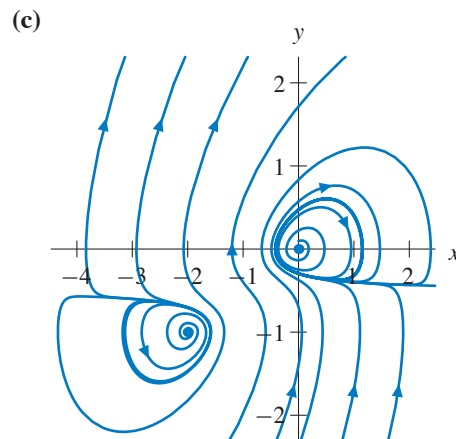
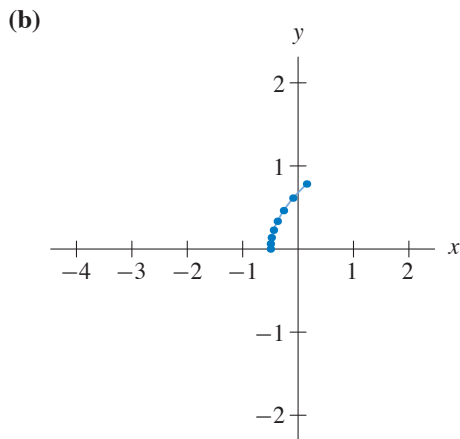

7. In order to be able to apply Euler's method to this second-order equation, we reduce the equation to a first-order system using $v = dy/dt$. We obtain

$$\begin{aligned} \frac{dy}{dt} &= v \\ \frac{dv}{dt} &= -2y - \frac{v}{2}. \end{aligned}$$

The choice of Δt has an important effect on the long-term behavior of the approximate solution curve. The approximate solution curve for $\Delta t = 0.25$ seems almost periodic. If $(y_0, v_0) = (2, 0)$, then we obtain $(y_5, v_5) \approx (-0.06, -2.81)$, $(y_{10}, v_{10}) \approx (-1.98, 1.15)$, $(y_{15}, v_{15}) \approx (0.87, 2.34)$, ...

However, the approximate solution curve for $\Delta t = 0.1$ spirals toward the origin. If $(y_0, v_0) = (2, 0)$, then we obtain $(y_5, v_5) \approx (1.62, -1.73)$, $(y_{10}, v_{10}) \approx (0.57, -2.44)$, $(y_{15}, v_{15}) \approx (-0.60, -1.94)$, ...

The following figure illustrates the results of Euler's method with $\Delta t = 0.1$.

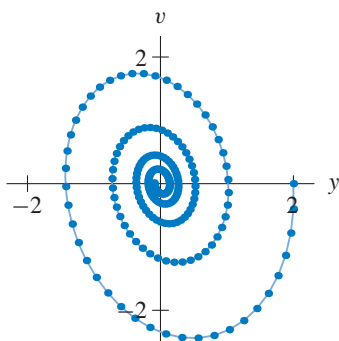

8. In order to be able to apply Euler's method to this second-order equation, we reduce the equation to a first-order system using $v = dy/dt$. We obtain

$$\begin{aligned}\frac{dy}{dt} &= v \\ \frac{dv}{dt} &= -y - \frac{v}{5}.\end{aligned}$$

The choice of Δt has an important effect on the long-term behavior of the approximate solution curve. The curve for $\Delta t = 0.25$ spirals away from the origin. If $(y_0, v_0) = (0, 1)$, then we obtain $(y_5, v_5) \approx (0.98, 0.23)$, $(y_{10}, v_{10}) \approx (0.64, -0.92)$, $(y_{15}, v_{15}) \approx (-0.63, -0.84)$, ...

The behavior of this approximate solution curve is deceiving. Consider the approximation we obtain if we halve that value of Δt . In other words, let $\Delta t = 0.125$. For $(y_0, v_0) = (2, 0)$, then we obtain $(y_5, v_5) \approx (0.58, 0.73)$, $(y_{10}, v_{10}) \approx (0.91, 0.21)$, $(y_{15}, v_{15}) \approx (0.89, -0.37)$, ...

The following figure illustrates how this approximate solution curve spirals toward the origin. (As we will see, this second approximation is much better than the first.)

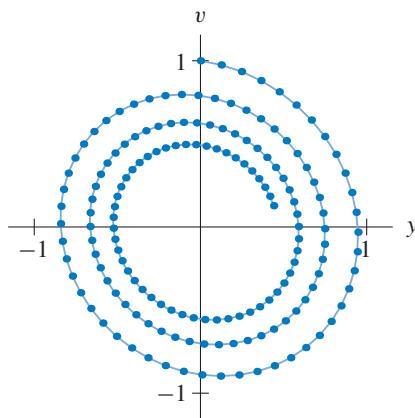

EXERCISES FOR SECTION 2.6

1. (a) If $y = 0$, the system is

$$\begin{aligned}\frac{dx}{dt} &= -x \\ \frac{dy}{dt} &= 0.\end{aligned}$$

Therefore, any solution that lies on the x -axis tends toward the origin. Solutions on negative half of the x -axis approach the origin from the left, and solutions on the positive half of the x -axis approach from the right. The third solution curve is the equilibrium point at the origin.

- (b)

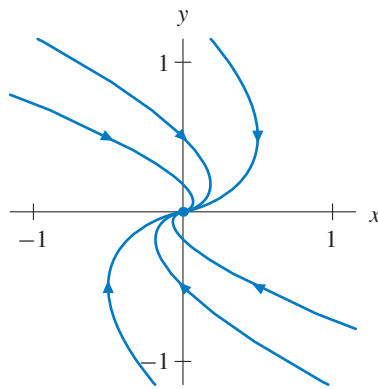

Since $dy/dt = -y$, we know that $y(t) = k_2 e^{-t}$ where k_2 can be any constant. Therefore, all solution curves not on the x -axis approach the x -axis but never touch it. Using the general solution for $y(t)$, the equation for dx/dt becomes $dx/dt = -x + k_2 e^{-t}$. This equation is a nonhomogeneous, linear equation, and there are many ways that we can solve it. The solution is $x(t) = k_1 e^{-t} + k_2 t e^{-t}$. We see that $(x(t), y(t)) \rightarrow (0, 0)$ as $t \rightarrow \infty$, but $(x(t), y(t))$ never equals $(0, 0)$ unless the initial condition is $(0, 0)$.

2. (a) There are infinitely many initial conditions that yield a periodic solution. For example, the initial condition $(2.00, 0.00)$ lies on a periodic solution.

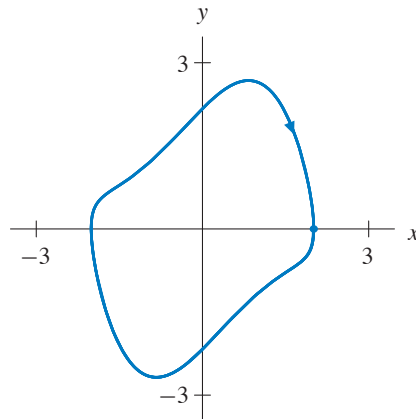

- (b) Any solution with an initial condition that is inside the periodic curve is trapped for all time. Namely, the period solution forms a “fence” that stops any solution with an initial condition that is inside the closed curve from “escaping.” Since the system is autonomous, no nonperiodic solution can touch the solution curve for this period solution.

3. With $x(t) = e^{-t} \sin(3t)$ and $y(t) = e^{-t} \cos(3t)$, we have

$$\begin{aligned}\frac{dx}{dt} &= -e^{-t} \sin(3t) + 3e^{-t} \cos(3t) \\ &= -x + 3y \\ \frac{dy}{dt} &= -3e^{-t} \sin(3t) - e^{-t} \cos(3t) \\ &= -3x - y\end{aligned}$$

Therefore, $\mathbf{Y}_1(t)$ is a solution.

4. With $x(t) = e^{-(t-1)} \sin(3(t-1))$ and $y(t) = e^{-(t-1)} \cos(3(t-1))$, we have

$$\begin{aligned}\frac{dx}{dt} &= -e^{-(t-1)} \sin(3(t-1)) + 3e^{-(t-1)} \cos(3(t-1)) \\ &= -x + 3y \\ \frac{dy}{dt} &= -3e^{-(t-1)} \sin(3(t-1)) - e^{-(t-1)} \cos(3(t-1)) \\ &= -3x - y\end{aligned}$$

Therefore, $\mathbf{Y}_2(t)$ is a solution.

5.

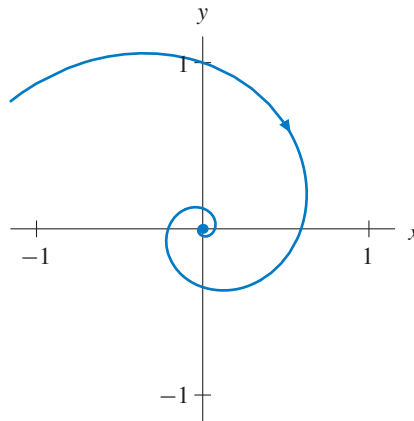

The solution curve swept out by $\mathbf{Y}_2(t)$ is identical to the solution curve swept out by $\mathbf{Y}_1(t)$ because $\mathbf{Y}_2(t)$ has $t-1$ wherever $\mathbf{Y}_1(t)$ has a t . Whenever $\mathbf{Y}_1(t)$ occupies a point in the phase plane, $\mathbf{Y}_2(t)$ occupies that same point exactly one unit of time later. Since these curves never occupy the same point at the same time, they do not violate the Uniqueness Theorem.

Although the exercise does not ask for a verification that these curves spiral into the origin, we can show that they do spiral by expressing the solution curve for $\mathbf{Y}_1(t)$ in terms of polar coordinates (r, θ) . Since $r^2 = x^2 + y^2$, we obtain $r = e^{-t}$, and

$$\frac{x(t)}{y(t)} = \frac{e^{-t} \sin 3t}{e^{-t} \cos 3t} = \tan 3t.$$

Also,

$$\frac{x(t)}{y(t)} = \tan \phi,$$

where $\phi = \pi/2 - \theta$. Therefore, $\tan 3t = \tan \phi$, and $3t = \pi/2 - \theta$. In other words, the angle θ changes according to the relationship $\theta = \pi/2 - 3t$.

These two computations imply that the solution curves for $\mathbf{Y}_1(t)$ and $\mathbf{Y}_2(t)$ spiral into the origin in a clockwise direction.

6. We need to assume that the hypotheses of the Uniqueness Theorem apply to the vector field on the parking lot. Then both Gib and Harry will follow the solution curve for their own starting point.
7. Assume the vector field satisfies the hypotheses of the Uniqueness Theorem. Since the vector field does not change with time, Gib will follow the same path as Harry, only one time unit behind.
8. (a) Differentiation yields

$$\frac{d\mathbf{Y}_2}{dt} = \frac{d(\mathbf{Y}_1(t + t_0))}{dt} = \mathbf{F}(\mathbf{Y}_1(t + t_0)) = \mathbf{F}(\mathbf{Y}_2(t))$$

where the second equality uses the Chain Rule and the other two equalities involve the definition of $\mathbf{Y}_2(t)$.

(b) They describe the same curve, but differ by a constant shift in parameterization.

9. From Exercise 8 we know that $\mathbf{Y}_1(t - 1)$ is a solution of the system and $\mathbf{Y}_1(1 - 1) = \mathbf{Y}_1(0) = \mathbf{Y}_2(1)$, so both $\mathbf{Y}_2(t)$ and $\mathbf{Y}_1(t - 1)$ occupy the point $\mathbf{Y}_1(0)$ at time $t = 1$. Hence, by the Uniqueness Theorem, they are the same solution. So $\mathbf{Y}_2(t)$ is a reparameterization by a constant time shift of $\mathbf{Y}_1(t)$.
10. (a) Since the system is completely decoupled, we can use separation of variables to obtain the general solution

$$(x(t), y(t)) = \left(2t + c_1, \frac{-1}{t + c_2} \right),$$

where c_1 and c_2 are arbitrary constants.

- (b) As t increases, any solution with $y(0) > 0$ tends to infinity. Any solution with $y(0) \leq 0$ is asymptotic to $y = 0$ as $t \rightarrow \infty$.
- (c) All solutions with $y(0) > 0$ blow up in finite time.
11. As long as $y(t)$ is defined, we have $y(t) \geq 1$ if $t \geq 0$ because dy/dt is nonnegative. Using this observation, we have

$$\frac{dx}{dt} \geq x^2 + 1$$

for all $t \geq 0$ in the domain of $x(t)$. Since $x(t) = \tan t$ satisfies the initial-value problem $dx/dt = x^2 + 1, x(0) = 0$, we see that the $x(t)$ -function for the solution to our system must satisfy

$$x(t) \geq \tan t.$$

Therefore, since $\tan t \rightarrow \infty$ as $t \rightarrow \pi/2^-$, $x(t) \rightarrow \infty$ as $t \rightarrow t_*$, where $0 \leq t_* \leq \pi/2$.

EXERCISES FOR SECTION 2.7

1. The system of differential equations is

$$\begin{aligned}\frac{dS}{dt} &= -\alpha SI \\ \frac{dI}{dt} &= \alpha SI - \beta I \\ \frac{dR}{dt} &= \beta I.\end{aligned}$$

Note that

$$\frac{dS}{dt} + \frac{dI}{dt} + \frac{dR}{dt} = -\alpha SI + (\alpha SI - \beta I) + \beta I = 0.$$

Hence, the sum $S(t) + I(t) + R(t)$ is constant for all t . Since the model assumes that the total population is divided into these three groups at $t = 0$, $S(0) + I(0) + R(0) = 1$. Therefore, $S(t) + I(t) + R(t) = 1$ for all t .

2. (a)

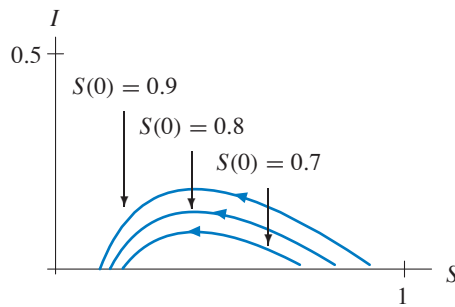

As $S(0)$ decreases, the maximum of $I(t)$ decreases, that is, the maximum number of infecteds decreases as the initial proportion of the susceptible population decreases. Furthermore, as $S(0)$ decreases, the limit of $S(t)$ as $t \rightarrow \infty$ increases. Consequently, the fraction of the population that contracts the disease during the epidemic decreases as the initial proportion of the susceptible population decreases.

(b) If $\alpha = 0.25$ and $\beta = 0.1$, the threshold value of the model is $\beta/\alpha = 0.1/0.25 = 0.4$. If $S(0) < 0.4$, then $dI/dt < 0$ for all $t > 0$. In other words, any influx of infecteds will decrease toward zero, preventing an epidemic from getting started. Therefore, 60% of the population must be vaccinated to prevent an epidemic from getting started.

3. (a) To guarantee that $dI/dt < 0$, we must have $\alpha SI - \beta I < 0$. Factoring, we obtain

$$(\alpha S - \beta)I < 0,$$

and since I is positive, we have $\alpha S - \beta < 0$. In other words,

$$S < \frac{\beta}{\alpha}.$$

Including initial conditions for which $S(0) = \beta/\alpha$ is debatable since $S(0) = \beta/\alpha$ implies that $I(t)$ is decreasing for $t \geq 0$.

(b) If $S(0) < \beta/\alpha$, then $dI/dt < 0$. In that case, any initial influx of infecteds will decrease toward zero, and the epidemic will die out. The fraction vaccinated must be at least $1 - \beta/\alpha$.

4. (a) We have

$$\frac{dI}{dS} = -1 + \frac{\rho}{S}.$$

Then $dI/dS = 0$ if and only if $S = \rho$. Furthermore, $d^2I/dt^2 = -\rho/S^2$ is always negative. By the Second Derivative Test, we conclude that the maximum value of $I(S)$ occurs at $S = \rho$. Evaluating $I(S)$ at $S = \rho$, we obtain the maximum value

$$I(\rho) = 1 - \rho + \rho \ln \rho.$$

- (b) For an epidemic to occur, $S(0) > \beta/\alpha$ (see Exercise 3). If $\beta > \alpha$, then $\beta/\alpha > 1$. Therefore, for an epidemic to occur under these conditions, $S(0) > 1$, which is not possible since $S(t)$ is defined as a proportion of the total population.

5. (a)

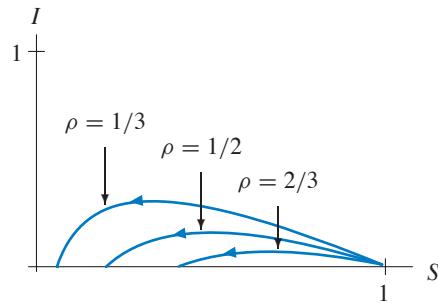

- (b)

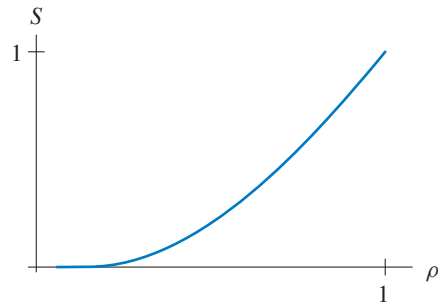

- (c) As ρ increases, the limit of $S(t)$ as $t \rightarrow \infty$ approaches 1. Therefore, as ρ increases, the fraction of the population that contract the disease approaches zero.

6. (a) Note that

$$\begin{aligned} \frac{dS}{dt} + \frac{dI}{dt} + \frac{dR}{dt} &= (-\alpha SI + \gamma R) + (\alpha SI - \beta I) + (\beta I - \gamma R) \\ &= 0 \end{aligned}$$

for all t .

- (b) If we substitute $R = 1 - (S + I)$ into dS/dt , we get

$$\begin{aligned} \frac{dS}{dt} &= -\alpha SI + \gamma(1 - (S + I)) \\ \frac{dI}{dt} &= \alpha SI - \beta I. \end{aligned}$$

- (c) If $dI/dt = 0$, then either $I = 0$ or $S = \beta/\alpha$.

If $I = 0$, then $dS/dt = \gamma(1 - S)$, which is zero if $S = 1$. We obtain the equilibrium point $(S, I) = (1, 0)$.

If $S = \beta/\alpha$, we set $dS/dt = 0$, and therefore,

$$\begin{aligned} -\alpha \left(\frac{\beta}{\alpha} \right) I + \gamma \left(1 - \left(\frac{\beta}{\alpha} + I \right) \right) &= 0 \\ -\beta I + \gamma - \frac{\gamma\beta}{\alpha} - \gamma I &= 0 \end{aligned}$$

$$\frac{\gamma(\alpha - \beta)}{\alpha} = (\beta + \gamma)I,$$

so

$$I = \frac{\gamma(\alpha - \beta)}{\alpha(\beta + \gamma)}.$$

Therefore, there exists another equilibrium point $(S, I) = \left(\frac{\beta}{\alpha}, \frac{\gamma(\alpha - \beta)}{\alpha(\beta + \gamma)}\right)$.

(d)

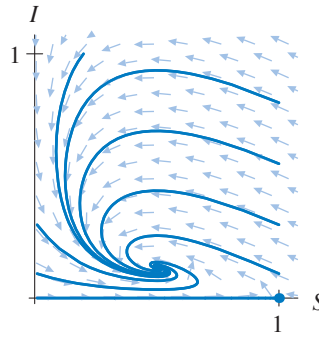

Given $\alpha = 0.3$, $\beta = 0.15$, and $\gamma = 0.05$, the equilibrium points are $(S, I) = (1, 0)$ and $(S, I) = (0.5, 0.125)$ (see part (b)). For any solution with $I(0) = 0$, the solution tends toward $(1, 0)$, which corresponds to a population where no one ever becomes infected. For all other initial conditions, the solutions tend toward $(0.5, 1.25)$ as t approaches infinity.

(e) We fix $\alpha = 0.3$ and $\beta = 0.15$. If γ is slightly greater than 0.05, the equilibrium point

$$(S, I) = \left(0.5, \frac{0.15\gamma}{0.15 + \gamma}\right)$$

shifts vertically upward, corresponding to a larger proportion of the population being infected as $t \rightarrow \infty$. For γ slightly less than 0.05, the same equilibrium point shifts vertically downward, corresponding to a smaller proportion of the population being infected as $t \rightarrow \infty$.

7. (a) If $I = 0$, both equations are zero, so the S -axis consists entirely of equilibrium points. If $I \neq 0$, then S would have to be zero. However, in that case, the second equation reduces to $dI/dt = -\beta I$, which cannot be zero by assumption. Therefore, all equilibrium points must lie on the S -axis.

(b) We have $dI/dt > 0$ if and only if $\alpha S\sqrt{I} - \beta I > 0$. Factoring out \sqrt{I} , we obtain

$$(\alpha S - \beta\sqrt{I})\sqrt{I} > 0.$$

Since $\sqrt{I} \geq 0$, we have

$$\alpha S - \beta\sqrt{I} > 0$$

$$-\beta\sqrt{I} > -\alpha S$$

$$\sqrt{I} < \frac{\alpha}{\beta} S$$

$$I < \left(\frac{\alpha}{\beta}\right)^2 S^2.$$

The resulting region is bounded by the S -axis and the parabola

$$I = \left(\frac{\alpha S}{\beta}\right)^2,$$

and lies in the half-plane $I > 0$.

- (c) The model predicts that the entire population will become infected. That is, $R(t) \rightarrow 1$ as $t \rightarrow \infty$.

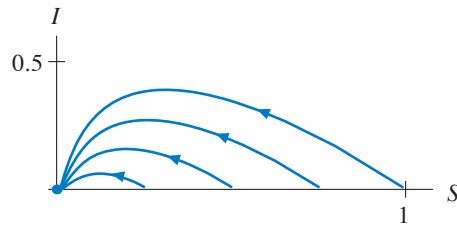

8. (a) Factoring the right-hand side of the equation for dI/dt , we get

$$\frac{dI}{dt} = (\alpha I - \gamma)S.$$

Therefore, the line $S = 0$ (the I -axis) is a line of equilibrium points. If $S \neq 0$, then $dI/dt = 0$ only if $I = \gamma/\alpha$. However, if $S \neq 0$ and $I = \gamma/\alpha$, then $dS/dt \neq 0$. So there are no other equilibrium points.

- (b) If $S \neq 0$, then S is positive. Therefore, $dI/dt > 0$ if and only if $\alpha I - \gamma > 0$ and $S > 0$. In other words $dI/dt > 0$ if and only if $I > \gamma/\alpha$ and $S > 0$.

- (c)

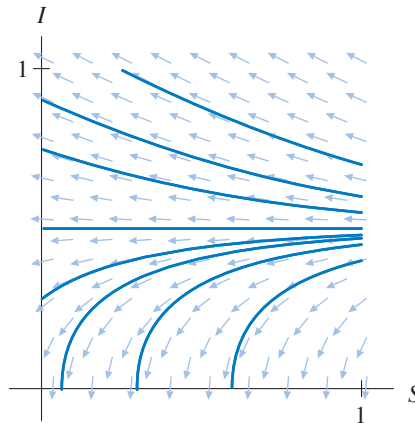

The model predicts that if $I(0) > 0.5$, then the infected (zombie) population will grow until there are no more susceptibles. If $I(0) = 0.5$, then the infected population will remain constant for all time. If $I(0) < 0.5$, then the entire infected population will die out over time.

9. (a) $\beta = 0.44$.
 (b) As $t \rightarrow \infty$, $S(t) \approx 19$. Therefore, the total number of infected students is 744.
 (c) Since β determines how quickly students move from being infected to recovered, a small value of β relative to α indicates that it will take a long time for the infected students to recover.

10. With 200 students vaccinated, there are only 563 students who can potentially contract the disease. The total population of students is still 763 students, but the vaccinated students decrease the interaction between infecteds and susceptibles. Starting with one infected student, we have $(S(0), I(0)) \approx (0.737, 0.001)$.

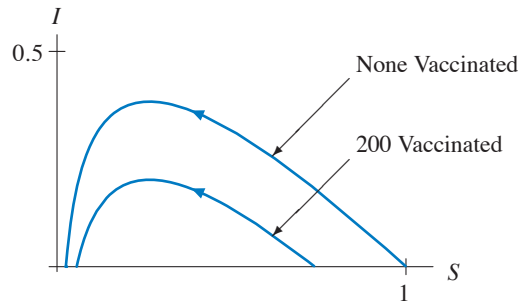

Note that if 200 students are vaccinated, the maximum of $I(t)$ is smaller. Consequently, the maximum number of infecteds is smaller if 200 students are vaccinated. More specifically, if none of the students are vaccinated, the maximum of $I(t)$ is approximately 293 students. If 200 students are vaccinated, the maximum of $I(t)$ is approximately 155 students.

In addition, the total number of students who catch the disease decreases if 200 students are initially vaccinated. More specifically, if none of the students are vaccinated, $S(t)$ is approximately 19 as $t \rightarrow \infty$. Thus, the total number of students infected is $763 - 19 = 744$ students. If 200 students are initially vaccinated, $S(t) \approx 42$ as $t \rightarrow \infty$. Thus, the total number of students infected is $563 - 42 = 521$ students.

EXERCISES FOR SECTION 2.8

1. (a) Substitution of $(0, 0, 0)$ into the given system of differential equations yields $dx/dt = dy/dt = dz/dt = 0$. Similarly, for the case of $(\pm 6\sqrt{2}, \pm 6\sqrt{2}, 27)$, we obtain

$$\begin{aligned}\frac{dx}{dt} &= 10(\pm 6\sqrt{2} - (\pm 6\sqrt{2})) \\ \frac{dy}{dt} &= 28(\pm 6\sqrt{2}) - (\pm 6\sqrt{2}) - 27(\pm 6\sqrt{2}) \\ \frac{dz}{dt} &= -\frac{8}{3}(27) - (\pm 6\sqrt{2})^2.\end{aligned}$$

Therefore, $dx/dt = dy/dt = dz/dt = 0$, and these three points are equilibrium points.

- (b) For equilibrium points, we must have $dx/dt = dy/dt = dz/dt = 0$. We therefore obtain the three simultaneous equations

$$\begin{cases} 10(y - x) = 0 \\ 28x - y - xz = 0 \\ -\frac{8}{3}z + xy = 0. \end{cases}$$

From the first equation, $x = y$. Eliminating y , we obtain

$$\begin{cases} x(27 - z) = 0 \\ -\frac{8}{3}z + x^2 = 0 \end{cases}$$

Then, $x = 0$ or $z = 27$. With $x = 0$, $z = 0$. With $z = 27$, $x^2 = 72$, hence $y = x = \pm 6\sqrt{2}$.

2. For equilibrium points, we must have $dx/dt = dy/dt = dz/dt = 0$. We obtain the three simultaneous equations

$$\begin{cases} 10(y - x) = 0 \\ \rho x - y - xz = 0 \\ -\frac{8}{3}z + xy = 0. \end{cases}$$

The first equation implies $x = y$. Eliminating y , we obtain

$$\begin{cases} x(\rho - 1 - z) = 0 \\ -\frac{8}{3}z + x^2 = 0. \end{cases}$$

Thus, $x = 0$, or $z = \rho - 1$. If $x = 0$ and therefore $y = 0$, then $z = 0$ by the last equation. Hence the origin $(0, 0, 0)$ is an equilibrium point for any value of ρ .

If $z = \rho - 1$, the last equation implies that $x^2 = 8(\rho - 1)/3$.

- (a) If $\rho < 1$, the equation $x^2 = 8(\rho - 1)/3$ has no solutions. If $\rho = 1$, its only solution is $x = 0$, which corresponds to the equilibrium point at the origin.
- (b) If $\rho > 1$, the equation $x^2 = 8(\rho - 1)/3$ has two solutions, $x = \pm\sqrt{8(\rho - 1)/3}$. Hence there are two more equilibrium points, at $x = y = \pm\sqrt{8(\rho - 1)/3}$ and $z = \rho - 1$.
- (c) Since the number of equilibrium points jumps from 1 to 3 as ρ passes through the value $\rho = 1$, $\rho = 1$ is a bifurcation value for this system.
3. (a) We have

$$\frac{dx}{dt} = 10(y - x) = 0 \quad \text{and} \quad \frac{dy}{dt} = 28x - y = 0,$$

so $x(t) = y(t) = 0$ for all t if $x(0) = y(0) = 0$.

- (b) We have

$$\frac{dz}{dt} = -\frac{8}{3}z,$$

so $z(t) = ce^{-8t/3}$. Since $z(0) = 1$, it follows that $c = 1$, and the solution is $x(t) = 0$, $y(t) = 0$, and $z(t) = e^{-8t/3}$.

- (c) If $z(0) = z_0$, it follows that $c = z_0$, so the solution is $x(t) = 0$, $y(t) = 0$, and $z(t) = z_0e^{-8t/3}$.

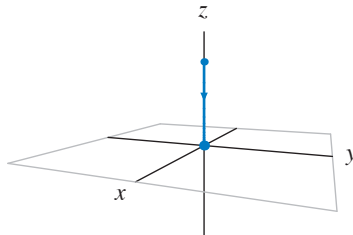

4. Let the parameter $r = 28$. If you select any initial condition that is not an equilibrium point, the solution winds around one of the two nonzero equilibrium points. A second solution whose initial condition differs from the first in the third decimal place is also computed. After a short interval of time, this second solution behaves in a manner that is quite different from the original solution. That is, it winds about the equilibrium points in a completely different pattern. While the two solutions ultimately seem to trace out the same figure, they do so in two very different ways.

No matter which two nearby initial conditions are selected, the result appears to be the same. Within a very short interval of time (usually less than the amount of time it takes the solutions to make twenty revolutions about the equilibrium points), the two solutions have separated and their subsequent trajectories are quite distinct.

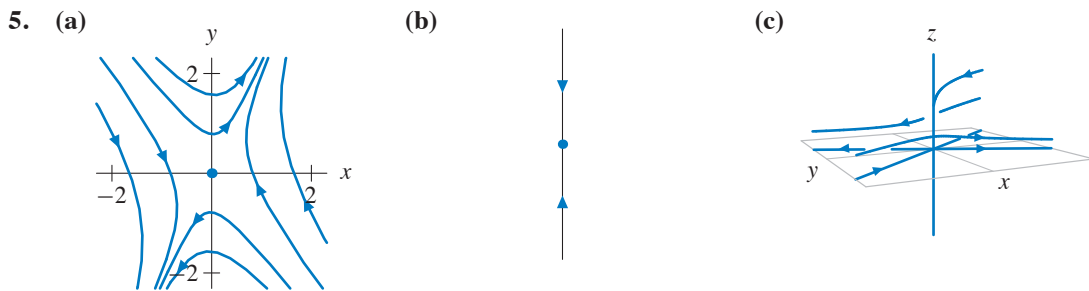

REVIEW EXERCISES FOR CHAPTER 2

- The simplest solution is an equilibrium solution, and the origin is an equilibrium point for this system. Hence, the equilibrium solution $(x(t), y(t)) = (0, 0)$ for all t is a solution.
- Note that $dy/dt > 0$ for all (x, y) . Hence, there are no equilibrium points for this system.
- Let $v = dy/dt$. Then $dv/dt = d^2y/dt^2$, and we obtain the system

$$\begin{aligned}\frac{dy}{dt} &= v \\ \frac{dv}{dt} &= 1.\end{aligned}$$

- First we solve $dv/dt = 1$ and get $v(t) = t + c_1$, where c_1 is an arbitrary constant. Next we solve $dy/dt = v = t + c_1$ and obtain $y(t) = \frac{1}{2}t^2 + c_1t + c_2$, where c_2 is an arbitrary constant. Therefore, The general solution of the system is

$$\begin{aligned}y(t) &= \frac{1}{2}t^2 + c_1t + c_2 \\ v(t) &= t + c_1.\end{aligned}$$

- The equation for dx/dt gives $y = 0$. If $y = 0$, then $\sin(xy) = 0$, so $dy/dt = 0$. Hence, every point on the x -axis is an equilibrium point.

6. Equilibrium solutions occur if both $dx/dt = 0$ and $dy/dt = 0$ for all t . We have $dx/dt = 0$ if and only if $x = 0$ or $x = y$. We have $dy/dt = 0$ if and only if $x^2 = 4$ or $y^2 = 9$. There are six equilibrium solutions:

$$(x(t), y(t)) = (0, 3) \text{ for all } t,$$

$$(x(t), y(t)) = (0, -3) \text{ for all } t,$$

$$(x(t), y(t)) = (2, 2) \text{ for all } t,$$

$$(x(t), y(t)) = (-2, -2) \text{ for all } t,$$

$$(x(t), y(t)) = (3, 3) \text{ for all } t, \text{ and}$$

$$(x(t), y(t)) = (-3, -3) \text{ for all } t.$$

7. First, we check to see if $dx/dt = 2x - 2y^2$ is satisfied. We compute

$$\frac{dx}{dt} = -6e^{-6t} \quad \text{and} \quad 2x - 2y^2 = 2e^{-6t} - 8e^{-6t} = -6e^{-6t}.$$

Second, we check to see if $dy/dt = -3y$. We compute

$$\frac{dy}{dt} = -6e^{-3t} \quad \text{and} \quad -3y = -3(2e^{-3t}) = -6e^{-3t}.$$

Since both equations are satisfied, $(x(t), y(t))$ is a solution.

8. The second-order equation for this harmonic oscillator is

$$\beta \frac{d^2y}{dt^2} + \gamma \frac{dy}{dt} + \alpha y = 0.$$

The corresponding system is

$$\begin{aligned} \frac{dy}{dt} &= v \\ \frac{dv}{dt} &= -\frac{\alpha}{\beta}y - \frac{\gamma}{\beta}v. \end{aligned}$$

9. From the equation for dx/dt , we know that $x(t) = k_1 e^{2t}$, where k_1 is an arbitrary constant, and from the equation for dy/dt , we have $y(t) = k_2 e^{-3t}$, where k_2 is another arbitrary constant. The general solution is $(x(t), y(t)) = (k_1 e^{2t}, k_2 e^{-3t})$.
10. Note that $(0, 2)$ is an equilibrium point for this system. Hence, the solution with this initial condition is an equilibrium solution.

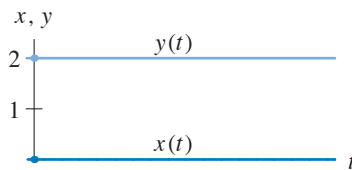

11. There are many examples. One is

$$\frac{dx}{dt} = (x^2 - 1)(x^2 - 4)(x^2 - 9)(x^2 - 16)(x^2 - 25)$$

$$\frac{dy}{dt} = y.$$

This system has equilibria at $(\pm 1, 0)$, $(\pm 2, 0)$, $(\pm 3, 0)$, $(\pm 4, 0)$, and $(\pm 5, 0)$.

12. One step of Euler's method is

$$\begin{aligned}(2, 1) + \Delta t \mathbf{F}(2, 1) &= (2, 1) + 0.5(3, 2) \\ &= (3.5, 2).\end{aligned}$$

13. The point $(1, 1)$ is on the line $y = x$. Along this line, the vector field for the system points toward the origin. Therefore, the solution curve consists of the half-line $y = x$ in the first quadrant. Note that the point $(0, 0)$ is not on this curve.

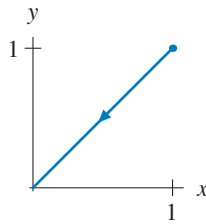

14. Let $\mathbf{F}(x, y) = (f(x, y), g(x, y))$ be the vector field for the original system. The vector field for the new system is

$$\begin{aligned}\mathbf{G}(x, y) &= (-f(x, y), -g(x, y)) \\ &= -(f(x, y), g(x, y)) \\ &= -\mathbf{F}(x, y).\end{aligned}$$

In other words, the directions of vectors in the new field are the opposite of the directions in the original field. Consequently, the phase portrait of new system has the same solution curves as the original phase portrait except that their directions are reversed. Hence, all solutions tend away from the origin as t increases.

15. True. First, we check the equation for dx/dt . We have

$$\frac{dx}{dt} = \frac{d(e^{-6t})}{dt} = -6e^{-6t},$$

and

$$2x - 2y^2 = 2(e^{-6t}) - 2(2e^{-3t})^2 = 2e^{-6t} - 8e^{-6t} = -6e^{-6t}.$$

Since that equation holds, we check the equation for dy/dt . We have

$$\frac{dy}{dt} = \frac{d(2e^{-3t})}{dt} = -6e^{-3t},$$

and

$$-3y = -3(2e^{-3t}) = -6e^{-3t}.$$

Since the equations for both dx/dt and dy/dt hold, the function $(x(t), y(t)) = (e^{-6t}, 2e^{-3t})$ is a solution of this system.

16. False. A solution to this system must consist of a pair $(x(t), y(t))$ of functions.
17. False. The components of the vector field are the right-hand sides of the equations of the system.
18. True. For example,

$$\begin{array}{l} \frac{dx}{dt} = y \quad \text{and} \quad \frac{dx}{dt} = 2y \\ \frac{dy}{dt} = x \quad \quad \quad \frac{dy}{dt} = 2x \end{array}$$

have the same direction field. The vectors in their vector fields differ only in length.

19. False. Note that $(x(0), y(0)) = (x(\pi), y(\pi)) = (0, 0)$. However, $(dx/dt, dy/dt) = (1, 1)$ at $t = 0$, and $(dx/dt, dy/dt) = (-1, -1)$ at $t = \pi$. For an autonomous system, the vector in the vector field at any given point does not vary as t varies. This function cannot be a solution of any autonomous system. (This function parameterizes a line segment in the xy -plane from $(1, 1)$ to $(-1, -1)$. In fact, it sweeps out the segment twice for $0 \leq t \leq 2\pi$.)
20. True. For an autonomous system, the rates of change of solutions depend only on position, not on time. Hence, if a function $(x_1(t), y_1(t))$ satisfies an autonomous system, then the function given by

$$(x_2(t), y_2(t)) = (x_1(t + T), y_1(t + T)),$$

where T is some constant, satisfies the same system.

21. True. Note that $\cos(t + \pi/2) = -\sin t$ and $\sin(t + \pi/2) = \cos t$. Consequently,

$$(-\sin t, \cos t) = (\cos(t + \pi/2), \sin(t + \pi/2)),$$

which is a time-translate of the solution $(\cos t, \sin t)$. Since the system is autonomous, a time-translate of a solution is another solution.

22. (a) To obtain an equilibrium point, dR/dt must equal zero at $R = 4,000$ and $C = 160$. Substituting these values into $dR/dt = 0$, we obtain

$$4,000 \left(1 - \frac{4,000}{130,000} \right) - \alpha(4,000)(160) = 0$$

$$4,000 \left(\frac{126,000}{130,000} \right) = 640,000 \alpha$$

$$\alpha = \frac{(4,000)(126,000)}{(640,000)(130,000)}$$

$$\approx 0.006.$$

Therefore, $\alpha \approx 0.006$ yields an equilibrium solution at $C = 160$ and $R = 4,000$.

- (b) For $\alpha = 0.006$, $C = 160$, and $R = 4,000$, we obtain

$$-\alpha RC = -(0.006)(4,000)(160) = 3,840.$$

Assuming that this value represents the *total* decrease in the rabbit population per year caused by the cats, then the number of rabbits *each* cat eliminated per year is

$$\frac{\text{Total number of rabbits eliminated}}{\text{Total number of cats}} = \frac{3,840}{160} = 24.$$

Therefore, each cat eliminated approximately 24 rabbits per year.

- (c) After the “elimination” of the cats, $C(t) = 0$. If we introduce a constant harvesting factor β into dR/dt , we obtain

$$\frac{dR}{dt} = R \left(1 - \frac{R}{130,000} \right) - \beta.$$

In order for the rabbit population to be controlled at $R = 4,000$, we need

$$\begin{aligned} \frac{dR}{dt} &= 4,000 \left(1 - \frac{4,000}{130,000} \right) - \beta = 0 \\ \frac{50,400}{13} &= \beta. \end{aligned}$$

Therefore, if $\beta = 50,400/13 \approx 3,877$ rabbits are harvested per year, then the rabbit population could be controlled at $R = 4,000$.

- 23.** False. The point $(0, 0)$ is an equilibrium point, so the Uniqueness Theorem guarantees that it is not on the solution curve corresponding to $(1, 0)$.
- 24.** False. From the Uniqueness Theorem, we know that the solution curve with initial condition $(1/2, 0)$ is trapped by other solution curves that it cannot cross (or even touch). Hence, $x(t)$ and $y(t)$ must remain bounded for all t .
- 25.** False. These solutions are different because they have different values at $t = 0$. However, they do trace out the same curve in the phase plane.
- 26.** True. The solution curve is in the second quadrant and tends toward the equilibrium point $(0, 0)$ as $t \rightarrow \infty$. It never touches $(0, 0)$ by the Uniqueness Theorem.
- 27.** False. The function $y(t)$ decreases monotonically, but $x(t)$ increases until it reaches its maximum at $x = -1$. It decreases monotonically after that.
- 28.** False. The graph of $x(t)$ for this solution has exactly one local maximum and no other critical points. The graph of $y(t)$ has four critical points, two local minimums and two local maximums.
- 29.** (a) The equilibrium points satisfy the equations $x = 2y$ and $\cos 2y = 0$. From the second equation, we conclude that

$$2y = \frac{\pi}{2} + k\pi,$$

where $k = 0, \pm 1, \pm 2, \dots$. Since $2y = x$, we see that the equilibria are

$$(x, y) = \dots, (-3\pi/2, -3\pi/4), (-\pi/2, -\pi/4), (\pi/2, \pi/4), (3\pi/2, 3\pi/4), (5\pi/2, 5\pi/4), \dots$$

(b)

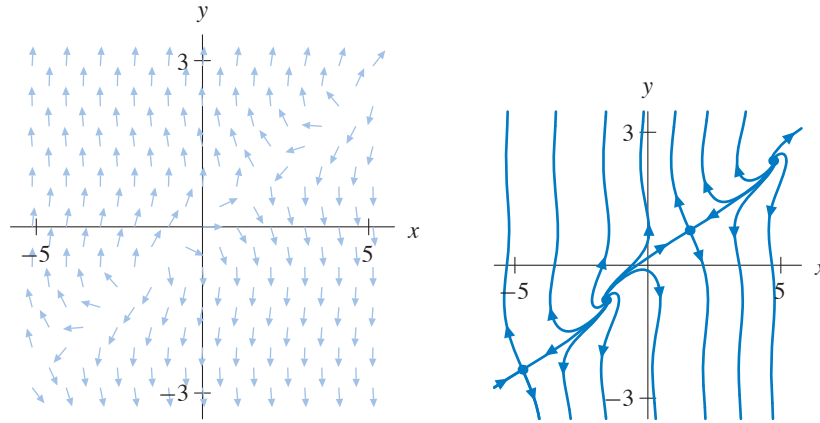

(c) Most solutions become unbounded in y as t increases. However, there appears to be a “curve” of solutions that tend toward the equilibria $\dots, (-\pi/2, -\pi/4), (3\pi/2, 3\pi/4), \dots$ as t increases.

30. If x_1 is a root of $f(x)$ (that is, $f(x_1) = 0$), then the line $x = x_1$ is invariant. In other words, given an initial condition of the form (x_1, y) , the corresponding solution curve remains on the line for all t . Along the line $x = x_1$, $y(t)$ obeys $dy/dt = g(y)$, so the line $x = x_1$ looks like the phase line of the equation $dy/dt = g(y)$.

Similarly, if $g(y_1) = 0$, then the line $y = y_1$ looks like the phase line for $dx/dt = f(x)$ except that it is horizontal rather than vertical.

Combining these two observations, we see that there will be vertical phase lines in the phase portrait for each root of $f(x)$ and horizontal phase lines in the phase portrait for each root of $g(y)$.

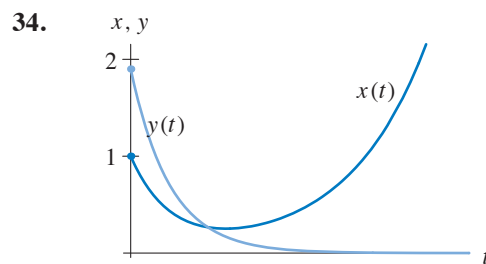
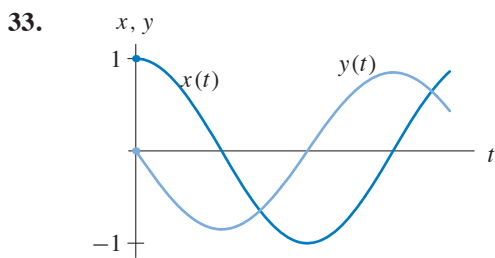
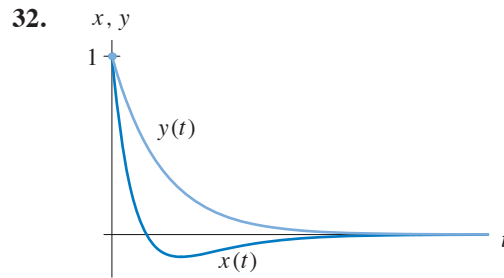
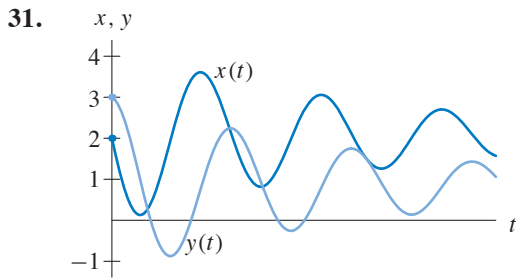

35. (a) First, we note that dy/dt depends only on y . In fact, the general solution of $dy/dt = 3y$ is $y(t) = k_2 e^{3t}$, where k_2 can be any constant. Substituting this expression for y into the equation for dx/dt , we obtain

$$\frac{dx}{dt} = x + 2k_2 e^{3t} + 1.$$

The general solution of the associated homogeneous equation is $x_h(t) = k_1 e^t$. To find a particular solution of the nonhomogeneous equation, we guess $x_p(t) = a e^{3t} + b$. Substituting this guess into the equation gives

$$3a e^{3t} = a e^{3t} + b + 2k_2 e^{3t} + 1,$$

so if $x_p(t)$ is a solution, we must have $3a = a + 2k_2$ and $b + 1 = 0$. Hence, $a = k_2$ and $b = -1$, and the function $x_p(t) = k_2 e^{3t} - 1$ is a solution of the nonhomogeneous equation.

Therefore, the general solution of the system is

$$\begin{aligned} x(t) &= k_1 e^t + k_2 e^{3t} - 1 \\ y(t) &= k_2 e^{3t}. \end{aligned}$$

- (b) To find the equilibrium points, we solve the system of equations

$$\begin{cases} x + 2y + 1 = 0 \\ 3y = 0, \end{cases}$$

so $(x, y) = (-1, 0)$ is the only equilibrium point.

- (c) To find the solution with initial condition $(-1, 3)$, we set

$$\begin{aligned} -1 &= x(0) = k_1 + k_2 - 1 \\ 3 &= y(0) = k_2, \end{aligned}$$

so $k_2 = 3$ and $k_1 = -3$. The solution with the desired initial condition is

$$(x(t), y(t)) = (-3e^t + 3e^{3t} - 1, 3e^{3t}).$$

- (d)

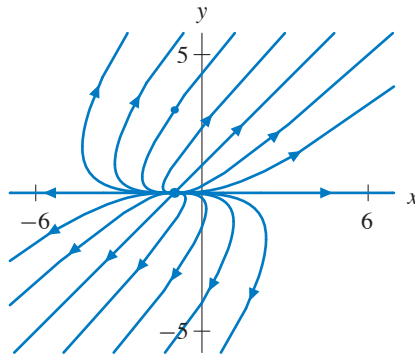

36. (a) For this system, we note that the equation for dy/dt depends only on y . In fact, this equation is separable and linear, so we have a choice of techniques for finding the general solution. The general solution for y is $y(t) = -1 + k_1 e^t$, where k_1 can be any constant.

Substituting $y = -1 + k_1 e^t$ into the equation for dx/dt , we have

$$\frac{dx}{dt} = (-1 + k_1 e^t)x.$$

This equation is a homogeneous linear equation, and its general solution is

$$x(t) = k_2 e^{-t+k_1 e^t},$$

where k_2 is any constant. The general solution for the system is therefore

$$(x(t), y(t)) = (k_2 e^{-t+k_1 e^t}, -1 + k_1 e^t),$$

where k_1 and k_2 are constants which we can adjust to satisfy any given initial condition.

- (b) Setting $dy/dt = 0$, we obtain $y = -1$. From $dx/dt = xy = 0$, we see that $x = 0$. Therefore, this system has exactly one equilibrium point, $(x, y) = (0, -1)$.
- (c) If $(x(0), y(0)) = (1, 0)$, then we must solve the simultaneous equations

$$\begin{cases} k_2 e^{k_1} = 1 \\ -1 + k_1 = 0. \end{cases}$$

Hence, $k_1 = 1$, and $k_2 = 1/e$. The solution to the initial-value problem is

$$(x(t), y(t)) = (e^{-1} e^{-t+e^t}, -1 + e^t) = (e^{e^t-t-1}, -1 + e^t).$$

(d)

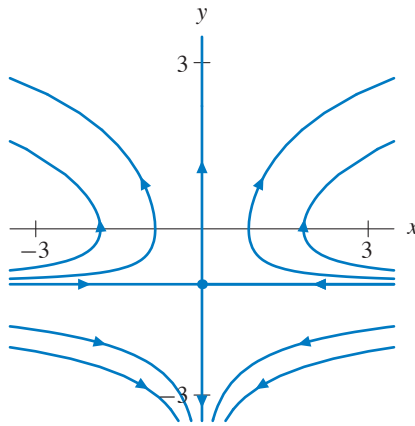

37. (a) Since θ represents an angle in this model, we restrict θ to the interval $-\pi < \theta < \pi$. The equilibria must satisfy the equations

$$\begin{cases} \cos \theta = s^2 \\ \sin \theta = -Ds^2. \end{cases}$$

Therefore,

$$\tan \theta = \frac{\sin \theta}{\cos \theta} = \frac{-Ds^2}{s^2} = -D,$$

and consequently, $\theta = -\arctan D$.

To find s , we note that $s^2 = \cos(-\arctan D)$. From trigonometry, we know that

$$\cos(-\arctan D) = \frac{1}{\sqrt{1+D^2}}.$$

If $-\pi < \theta < \pi$, there is a single equilibrium point for each value of the parameter D . It is

$$(\theta, s) = \left(-\arctan D, \frac{1}{\sqrt{1+D^2}} \right).$$

- (b) The equilibrium point represents motion along a line at a given angle from the horizon with a constant speed.